

1 Versant 8'x8'

1-sided shed 8'x8'

Guide d'utilisation / Manual

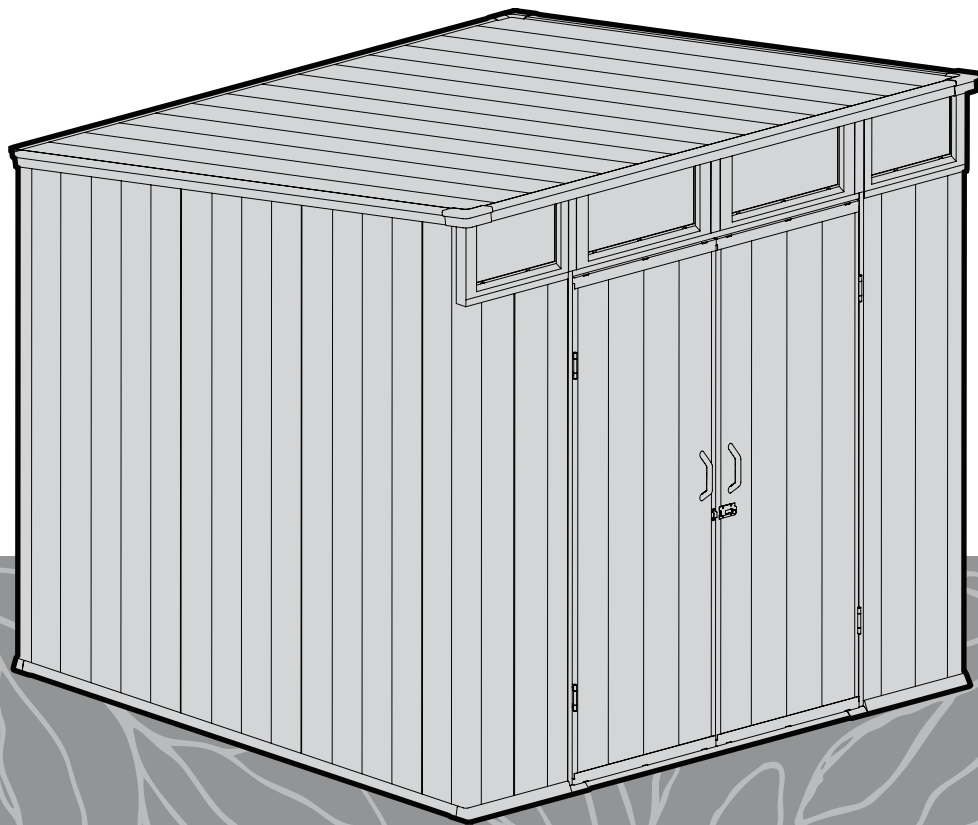

SOMMAIRE / CONTENT

AVANT L'ASSEMBLAGE ILLUSTRER BEFORE ASSEMBLE ILLUSTRATION	01
LISTE DES PIÈCES PARTS LIST	03
ASSEMBLAGE DU PLANCHER FLOOR ASSEMBLY	11
ASSEMBLAGE DU CADRE FRAME ASSEMBLY	19
ASSEMBLAGE DU MUR WALL ASSEMBLY	27
ASSEMBLAGE DES FENÊTRES WINDOW ASSEMBLY	39
ASSEMBLAGE DU TOIT ROOF ASSEMBLY	47

FIXATION TOTALE	
WHOLE FIXATION	55
ASSEMBLAGE DE PORTES	
DOOR ASSEMBLY	63
DIRECTIVES ET GARANTIE	
GUIDELINES & WARRANTY	75

Préparation du site / Site Preparation

Niveler la surface du sol / Level the ground surface

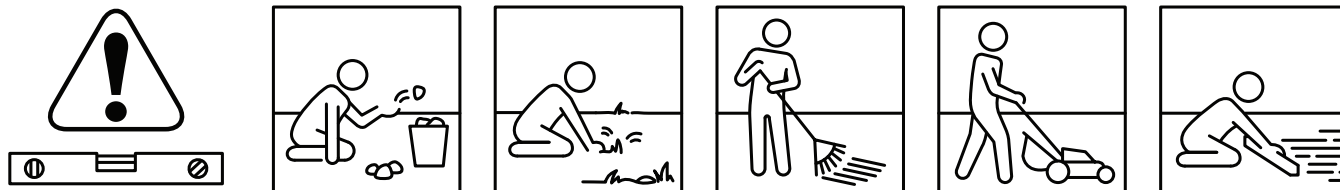

Recommandation de la plateforme / Platform Recommendation

Option A

Bois / Wooden

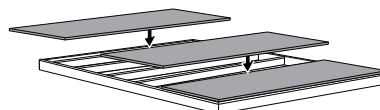

Option B

Béton / Concrete

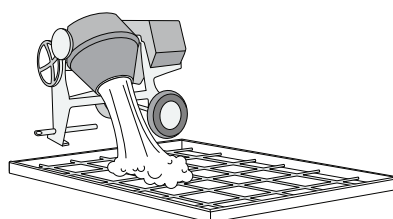

Option C

Sol / Soil

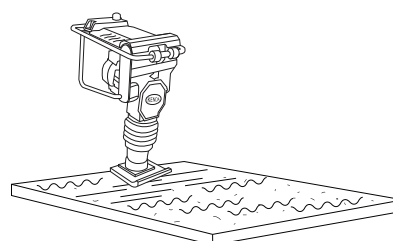

Avant de commencer l'assemblage / Before Starting Assembly

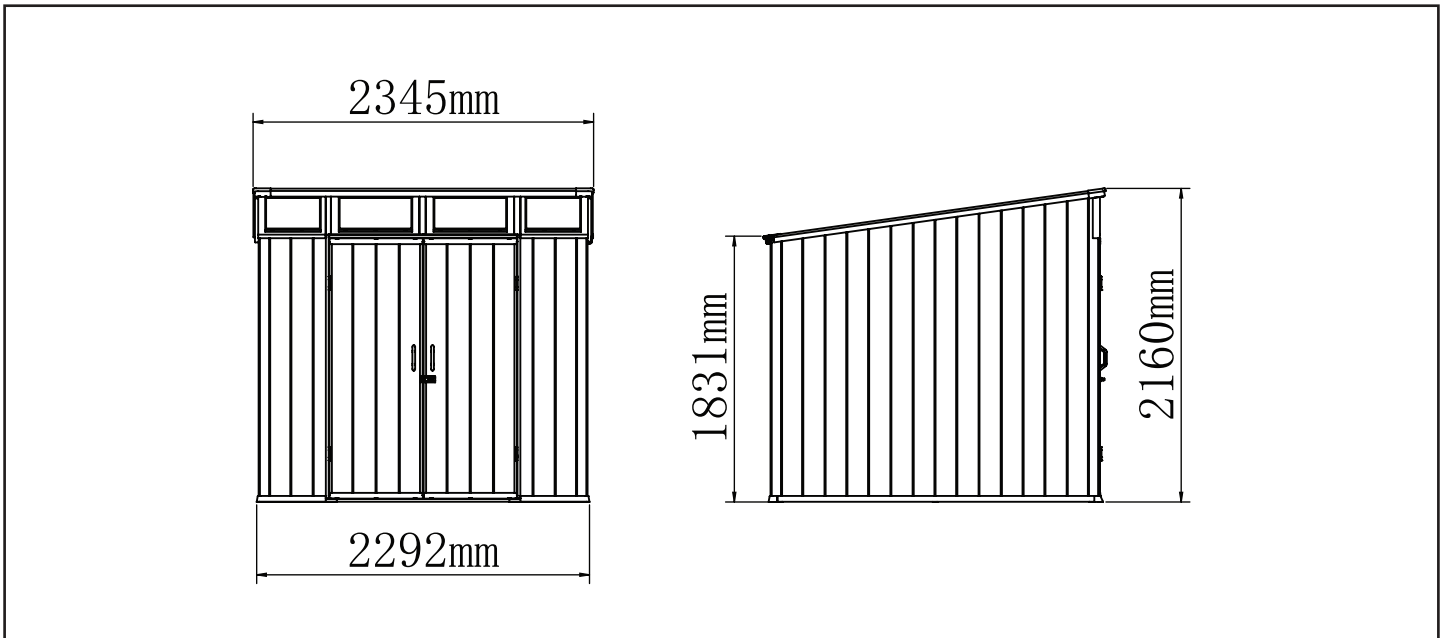

Lisez les consignes d'entretien et de sécurité à la fin de ce manuel. Vérifiez qu'il ne manque aucune pièce ou qu'aucune pièce n'est endommagée avant de commencer ou d'organiser le montage. Passez en revue toutes les instructions d'assemblage. Assemblez toutes les pièces conformément aux instructions de ce manuel. Ne sautez aucune étape.

Read the care and safety guidelines at the end of this manual. Check to ensure that there are no missing or damaged parts before starting or arranging assembly. Review all assembly instructions. Assemble all the parts according to the directions in this manual. Do not skip any steps.

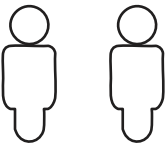

Pour l'accès extérieur pendant le montage, veillez à laisser suffisamment d'espace autour du site de montage du cabanon.

For external access during assembly, make sure to leave enough room around the outside of the shed assembly site.



<p>2 personnes requises 2 People Required</p>	
<p>Outils nécessaires Tools Needed</p>	

LISTE DES PIÈCES / PARTS LIST



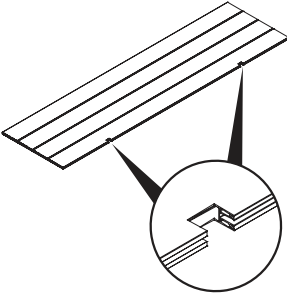
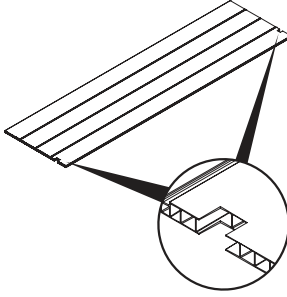
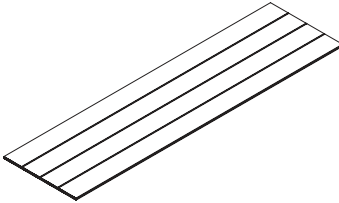
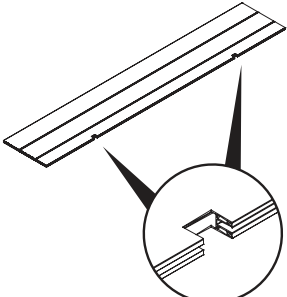

Retirez toutes les pièces de l'emballage et étalez-les sur une surface de travail propre. Des lettres de code sont imprimées sur chaque pièce pour en faciliter l'identification.

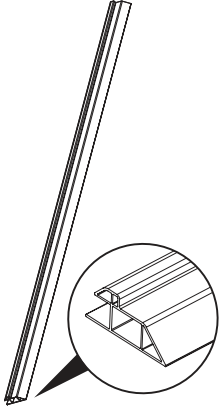
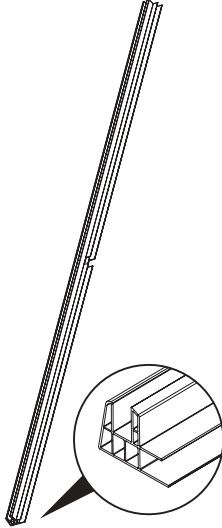
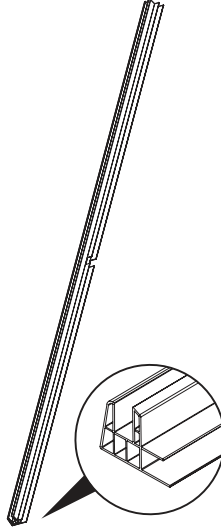
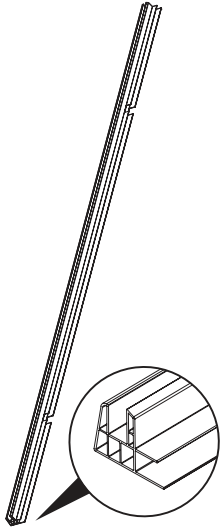
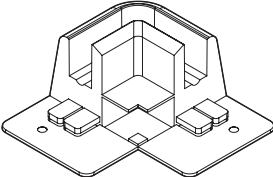
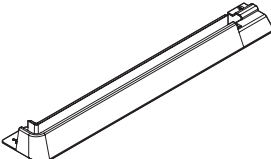
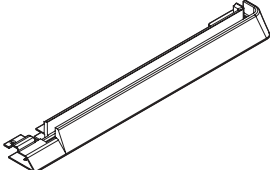
Remove all parts from the package(s) and spread them out on a clean work surface. Code letters are imprinted on each part for easy identification.

Pièces de plancher / Floor Parts

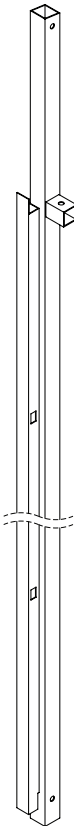
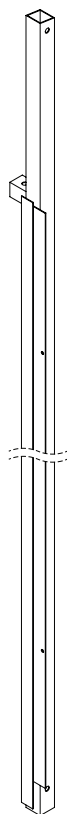
<p style="text-align: center;">KD098</p>  <p style="text-align: center;">2218 x 600 mm</p>	<p style="text-align: center;">KD099</p>  <p style="text-align: center;">2218 x 600 mm</p>	<p style="text-align: center;">KD100</p>  <p style="text-align: center;">2218 x 600 mm</p>	<p style="text-align: center;">KD101</p>  <p style="text-align: center;">2218 x 400 mm</p>	
<p style="text-align: center;">KD102</p>  <p style="text-align: center;">2218 mm</p> <p style="text-align: center;">x3</p>	<p style="text-align: center;">KD009</p>  <p style="text-align: center;">1274 mm</p>	<p style="text-align: center;">KD103</p>  <p style="text-align: center;">2184 mm</p>	<p style="text-align: center;">KD104</p>  <p style="text-align: center;">2184 mm</p>	<p style="text-align: center;">KD105</p>  <p style="text-align: center;">2171 mm</p>
<p style="text-align: center;">KD015</p>  <p style="text-align: center;">x2</p>		<p style="text-align: center;">KD016</p> 	<p style="text-align: center;">KD017</p> 	

Pièces du cadre / Frame Parts

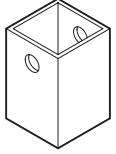
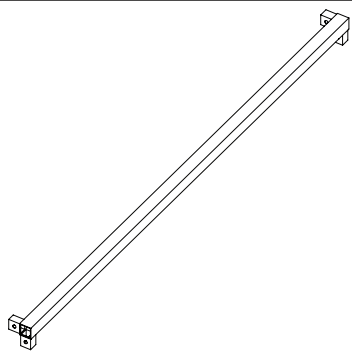
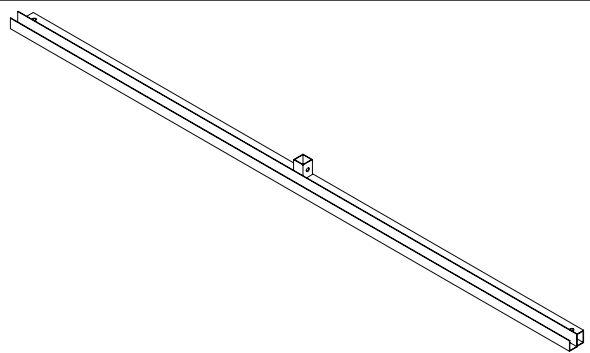
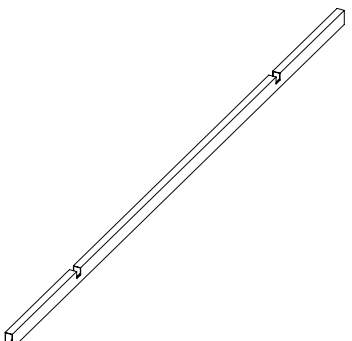
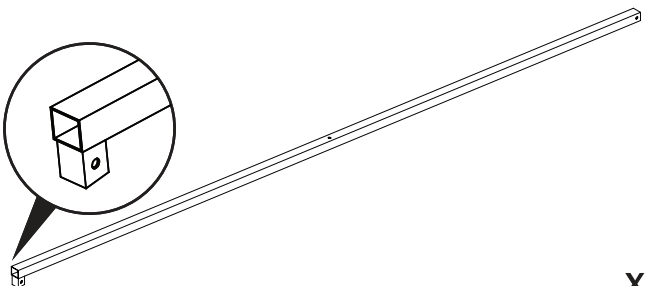
<p>KD155</p> 	<p>KD156</p> 	<p>KD157</p>  <p>x2</p>	<p>KD158</p>  <p>x2</p>	<p>KD162</p>  <p>KD029</p>  <p>x6</p>
<p>KD159</p>		<p>KD160</p>		
				
<p>KD161</p>		<p>KD190</p>		
		 <p>x2</p>		

Pièces murales.1 / Wall Parts.1

KD163	KD164	KD165	KD166	KD167	KD168
KD169	KD170	KD171	KD172	KD173	KD174
 x3					
KD175	KD176		KD177		KD178
	 1784mm x2		 1983mm x2		 1987mm x2

Cadre de fenêtre en plastique / Plastic window frame

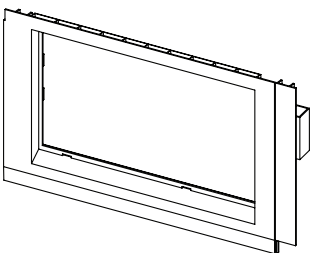
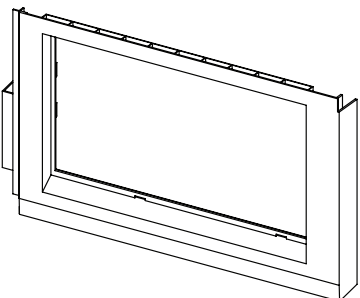
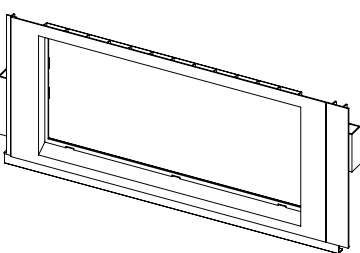
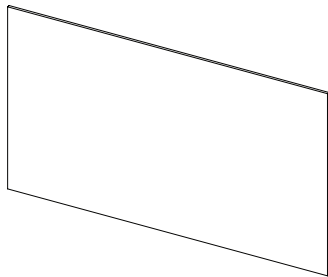
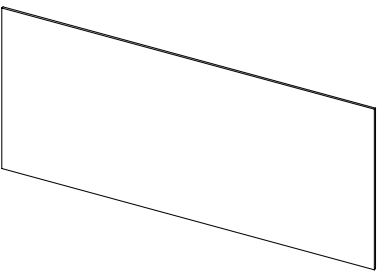



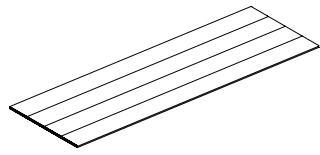
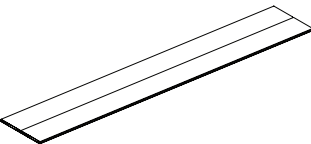
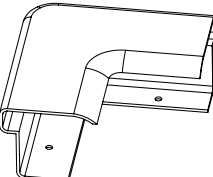
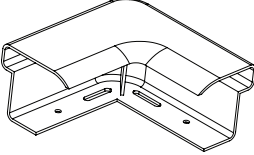
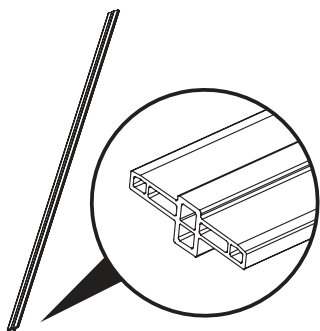
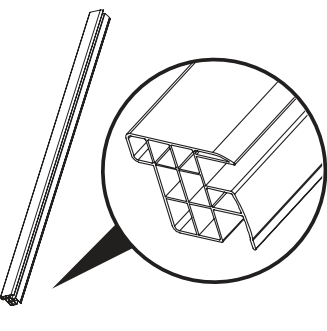
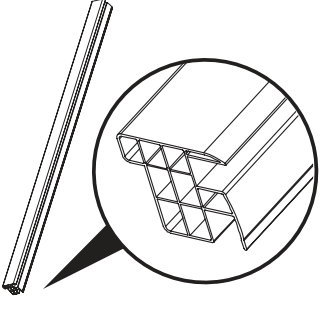
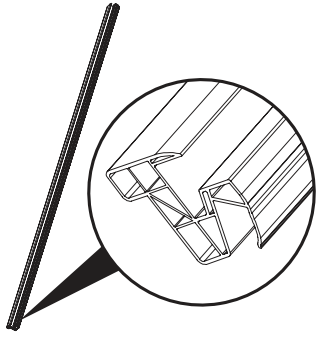

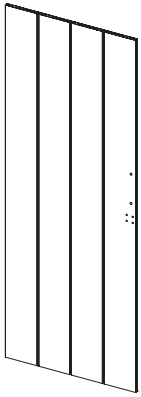
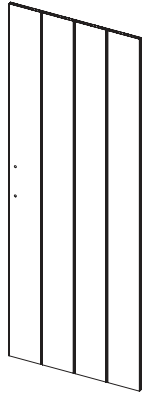
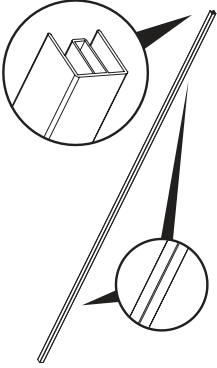
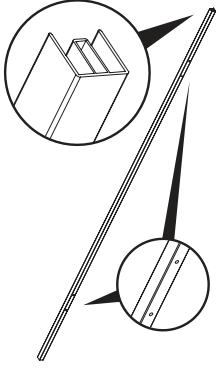
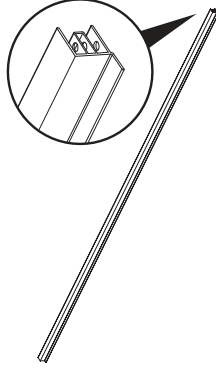
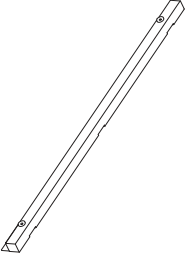
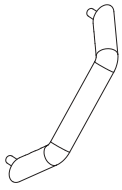
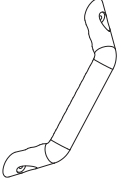
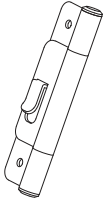
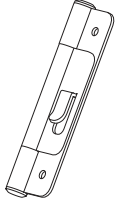
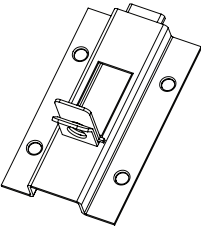
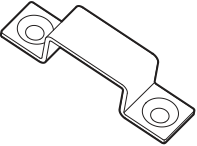
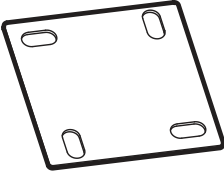
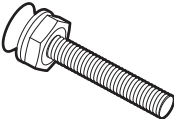
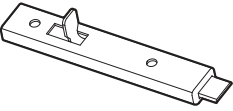

KD179	KD180	KD181
		
		x2
KD191		KD192
		
x2		x2

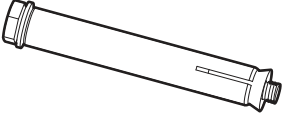
Pièces pour toit / Roof Parts

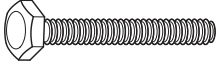
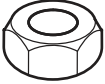
KD182	KD183	KD184	KD185
			
<i>2295 * 640 mm</i> x3	<i>2295 * 482 mm</i>	x2	x2
KD186	KD187	KD188	KD189
			
<i>2295 mm</i> x3	<i>2248 mm</i> x2	<i>2193 mm</i>	<i>2193 mm</i>

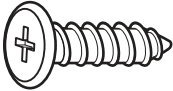
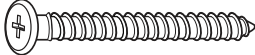
Pièces pour portes / Door Parts

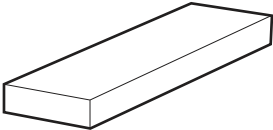
KD061	KD062	KD066	KD067	KD068
 <p data-bbox="115 710 297 738">1782 x 640 mm</p>	 <p data-bbox="402 710 584 738">1782 x 640 mm</p>	 <p data-bbox="683 710 797 738">1750 mm</p>	 <p data-bbox="969 710 1219 738">1750 mm x2</p>	 <p data-bbox="1252 710 1365 738">1750 mm</p>
KD069	KD070	KD071	KD072	KD073
 <p data-bbox="305 1300 358 1338">x4</p>	 <p data-bbox="597 1300 646 1338">x2</p>	 <p data-bbox="883 1300 932 1338">x2</p>	 <p data-bbox="1166 1300 1214 1338">x2</p>	 <p data-bbox="1458 1300 1507 1338">x2</p>
KD075	KD076	KD077	KD078	KD079
			 <p data-bbox="1170 1986 1219 2023">x4</p>	 <p data-bbox="1458 1986 1507 2023">x2</p>

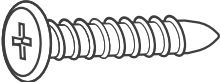
<p>KD080</p>	<p>KD118</p>	<p>KD081</p>	<p>KD082</p>
 <p>x7</p>	 <p>x7</p>	 <p>x21</p>	 <p>x19</p>
<p>KD083</p>	<p>KD084</p>	<p>KD085</p>	<p>KD119</p>
 <p>x188</p>	 <p>x16</p>	 <p>x39</p>	
<p>KD120</p>	<p>KD225</p>		<p>KD226</p>
			

Outil supplémentaire Illustrer / Extra Tool Illustrate

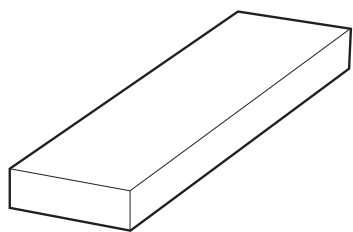

Cube magique
Magic Cube

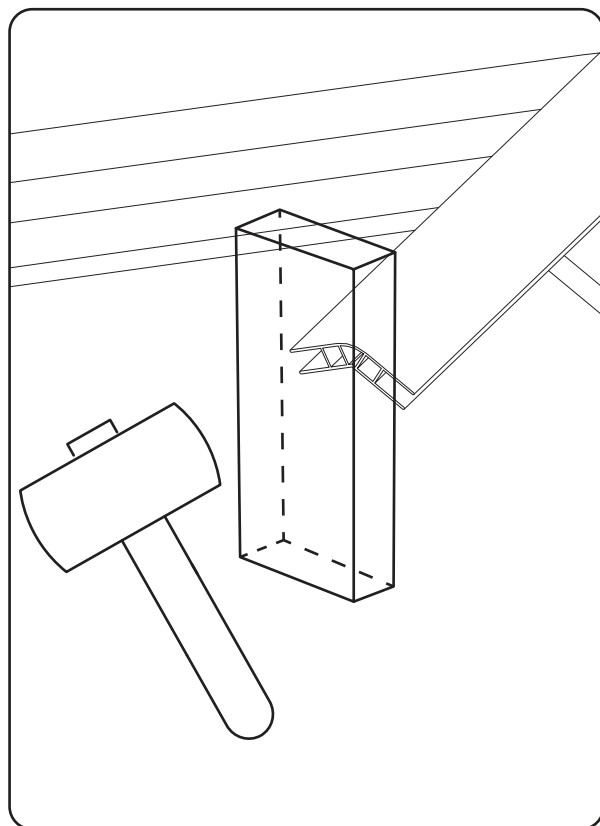
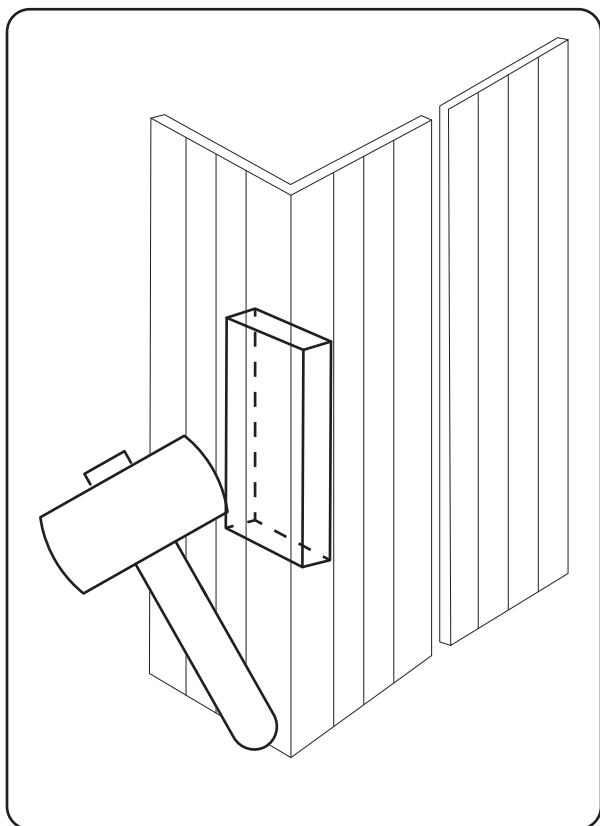
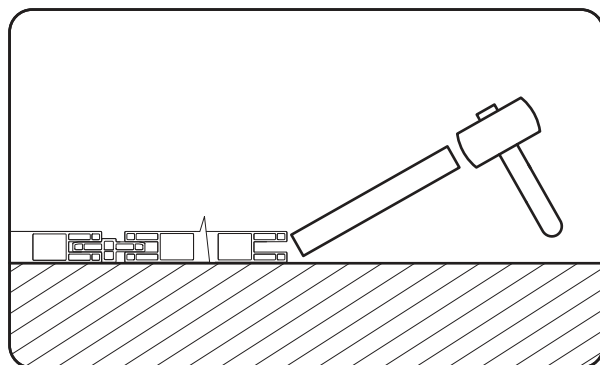
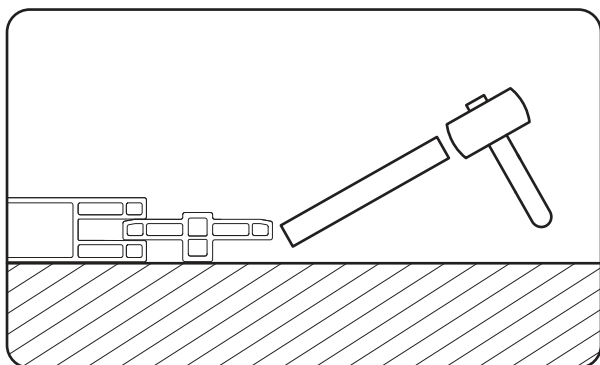

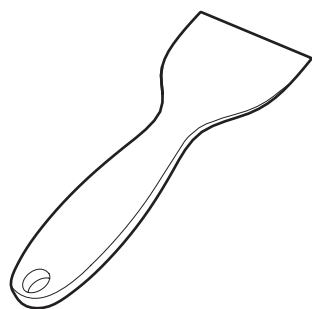

KD119

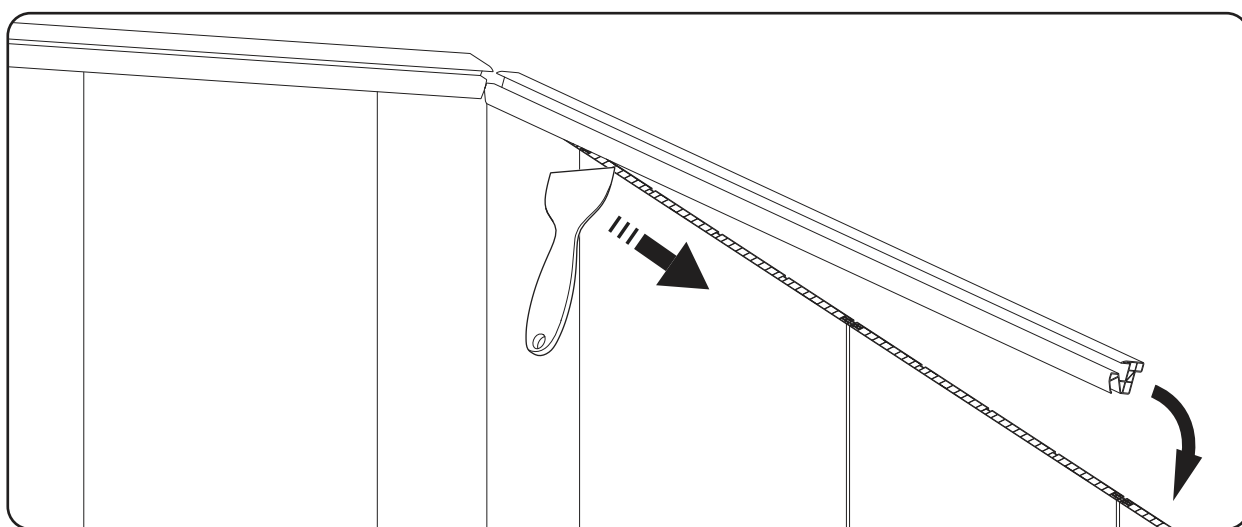
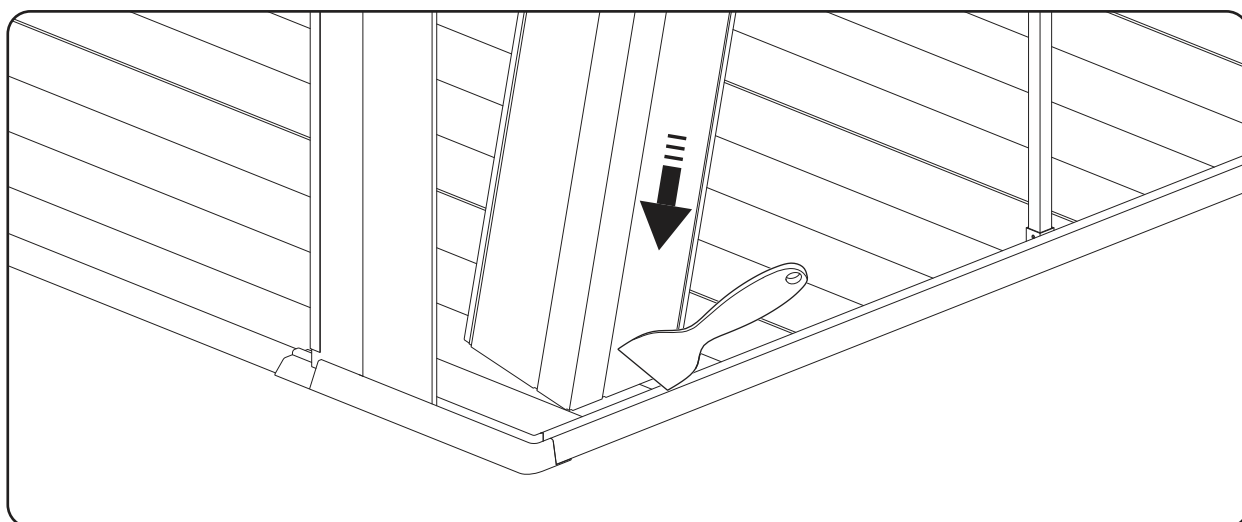

Assemblage du plancher

Floor Assembly

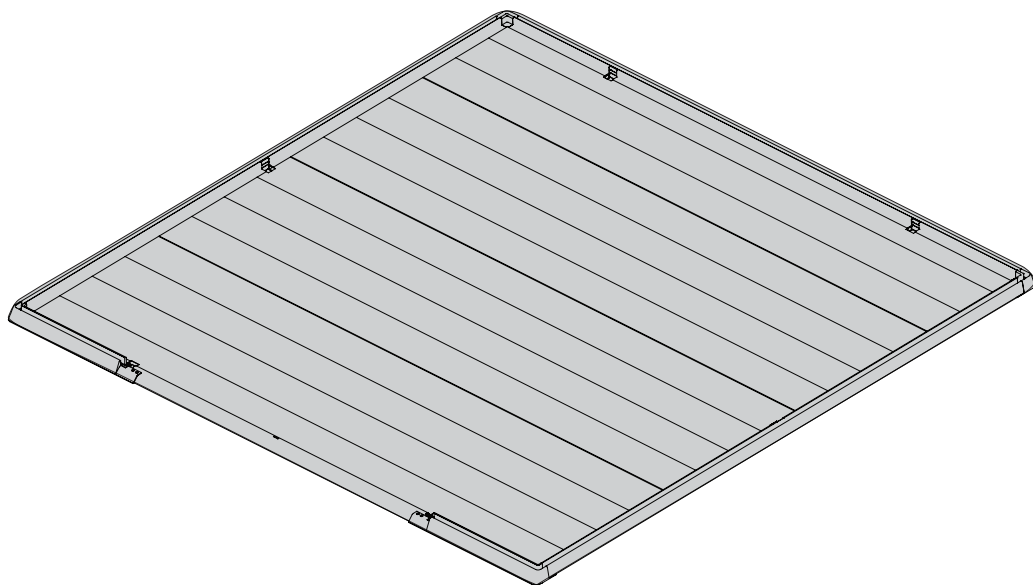

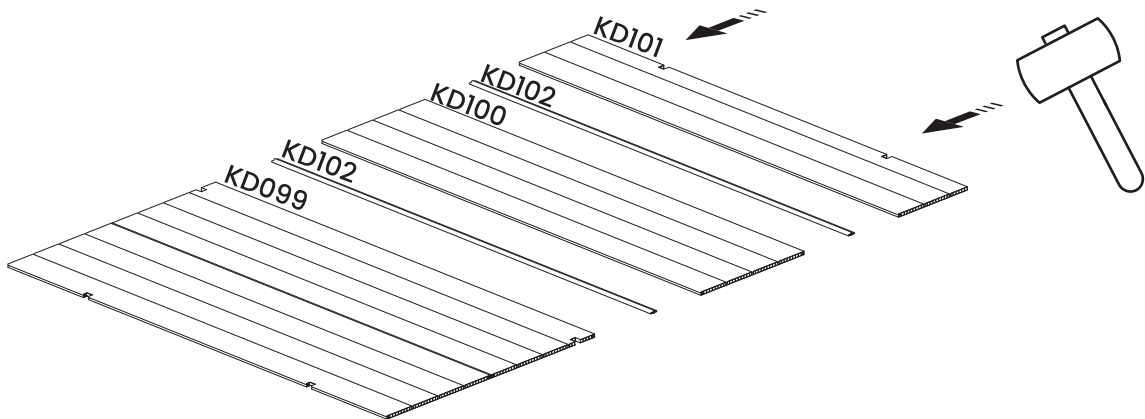
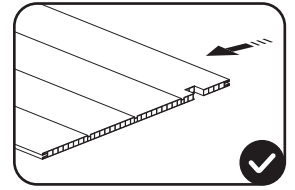
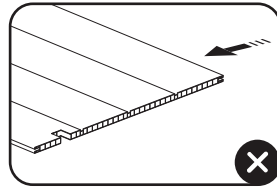
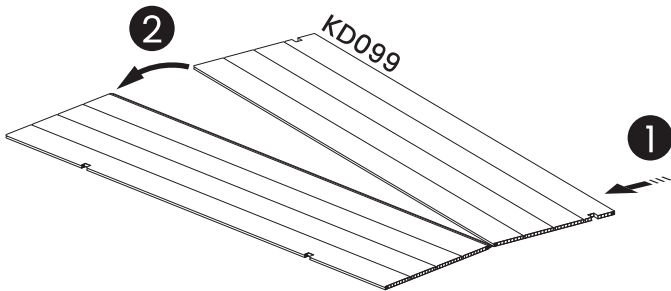
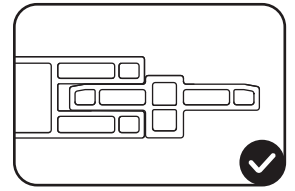
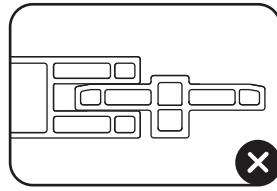
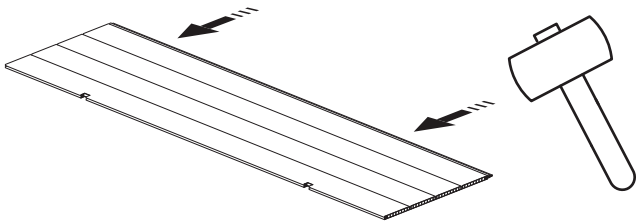
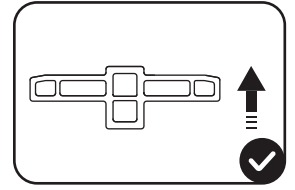
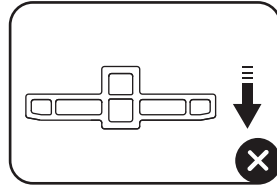
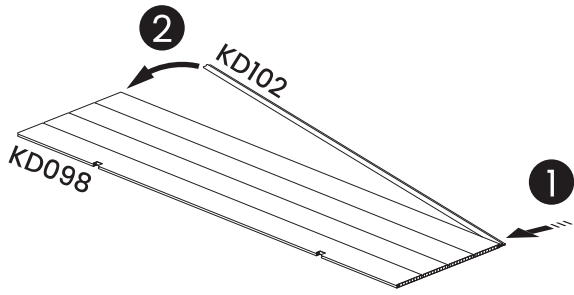

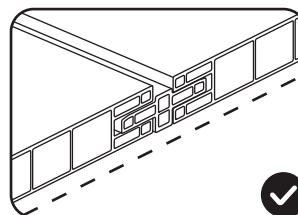
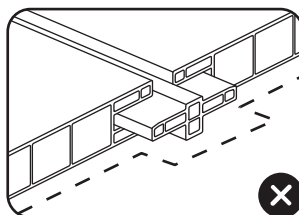
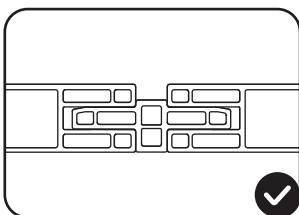
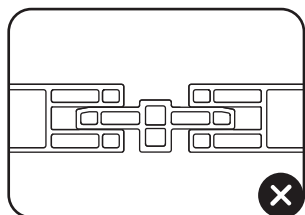
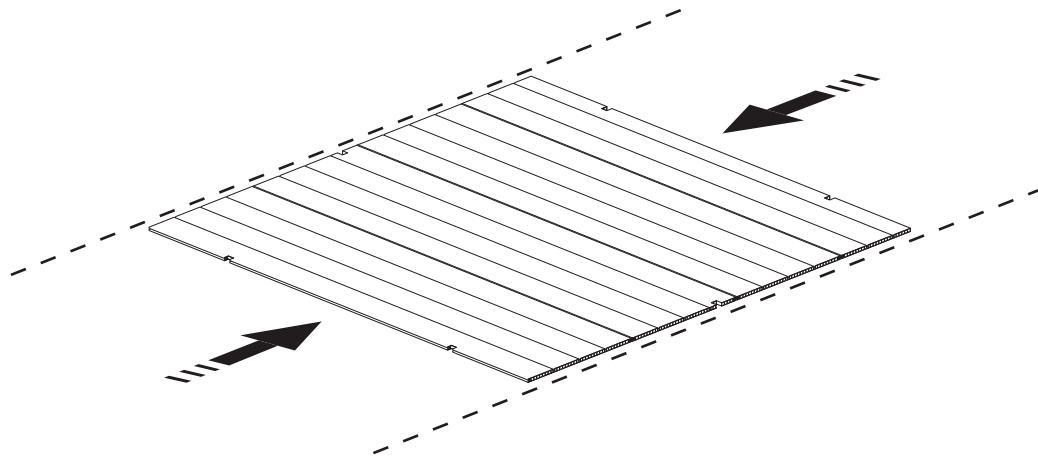

	<p>KD083</p>	<p>x18</p>
---	--------------	------------

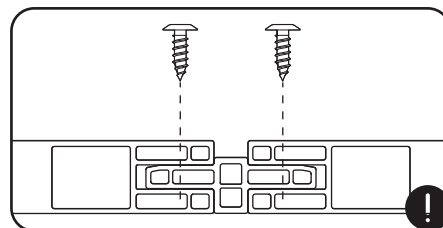
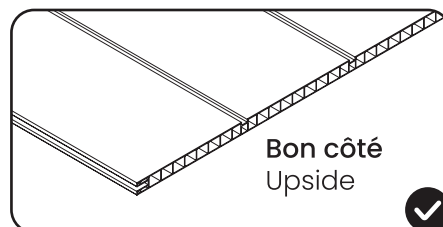
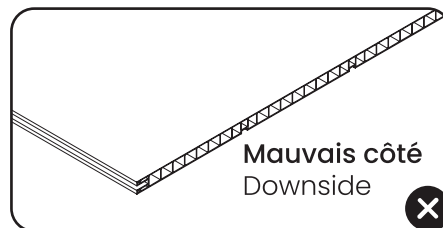
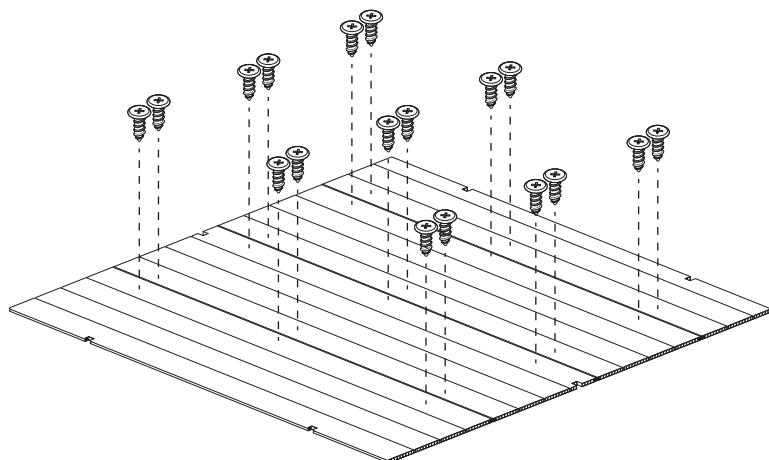

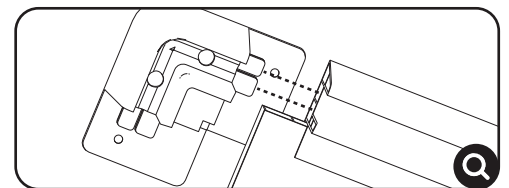
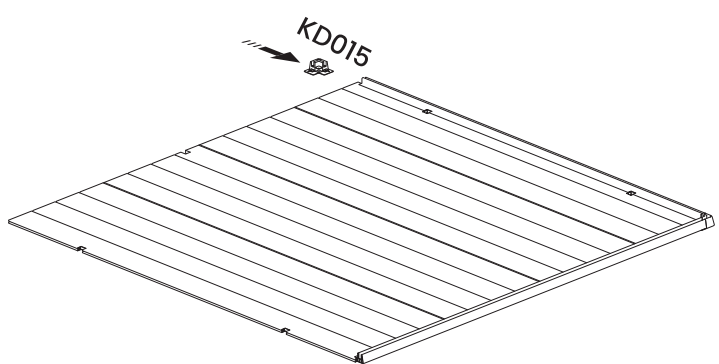
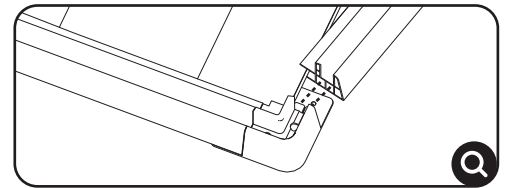
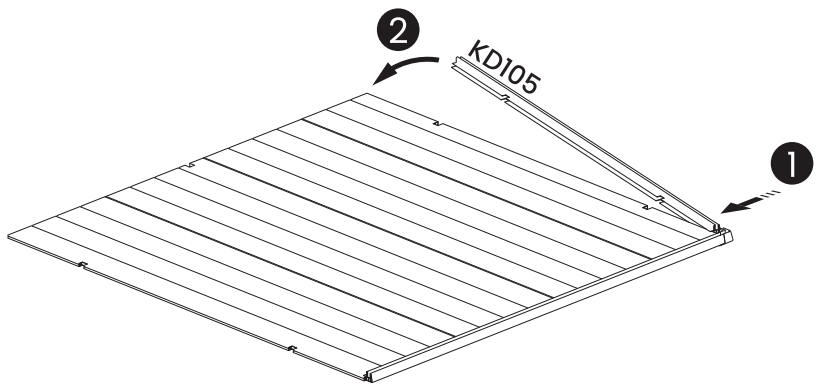
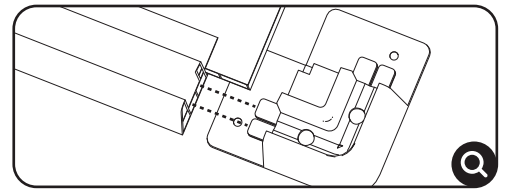
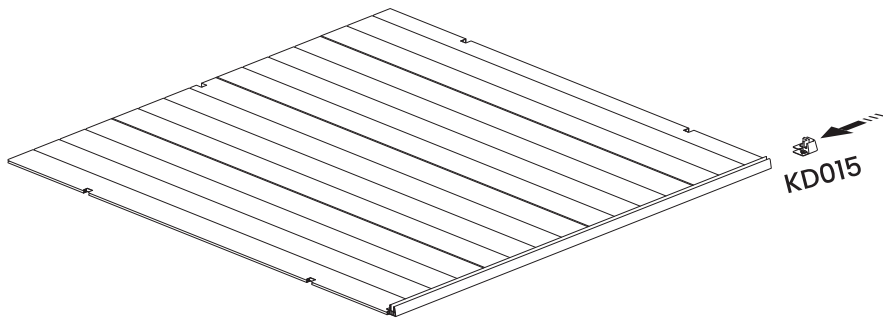
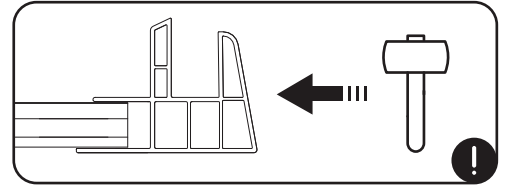
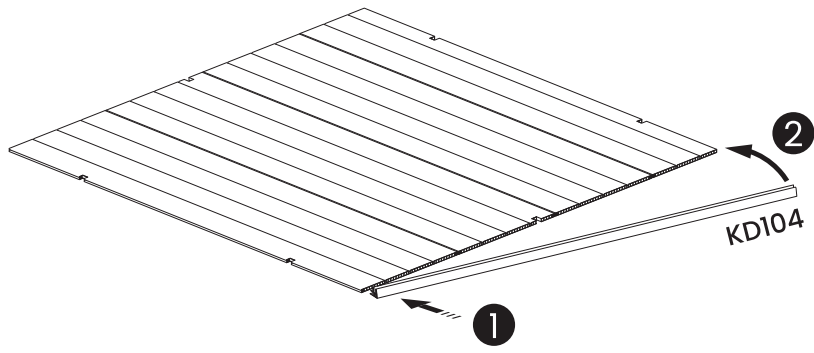

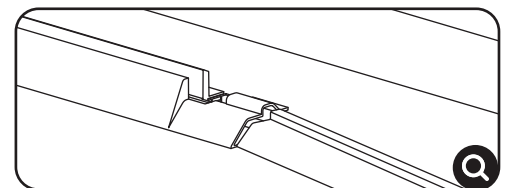
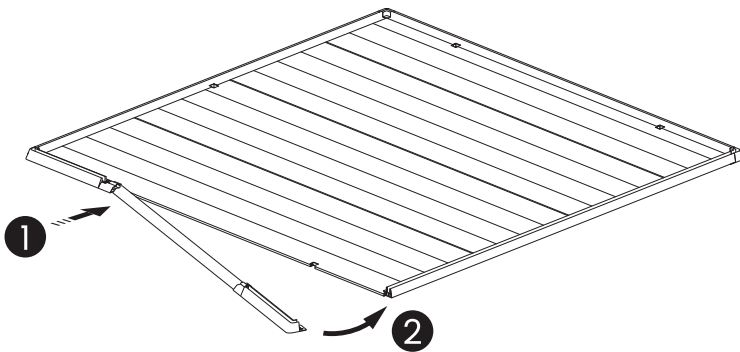
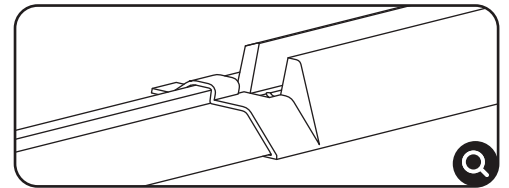
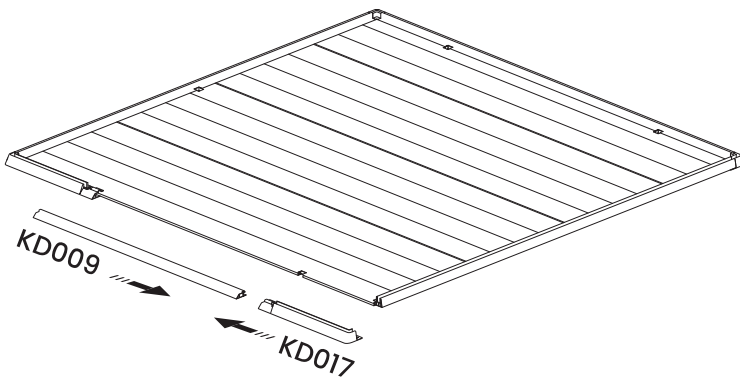
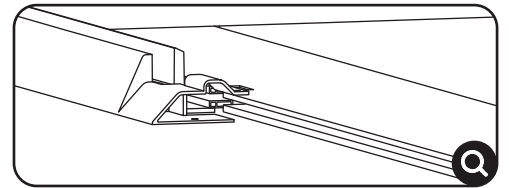
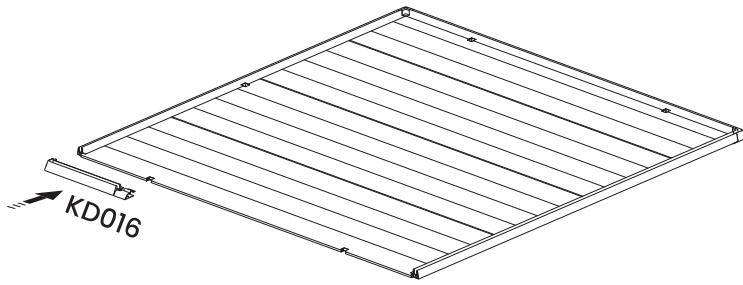
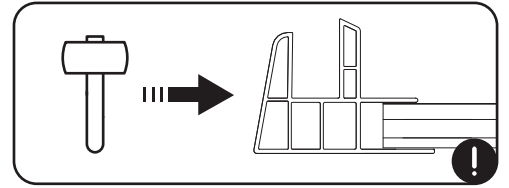
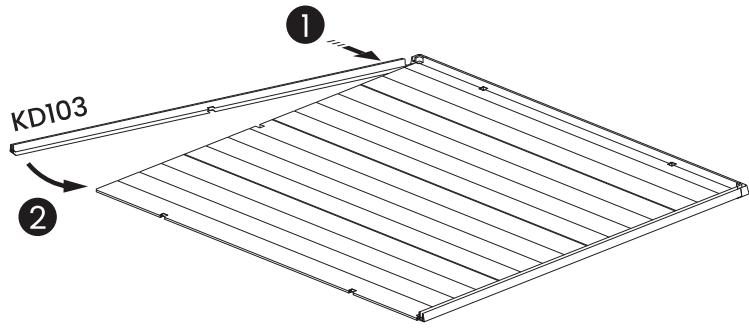



Vérifier la marge sur une ligne

Check the margin on a line

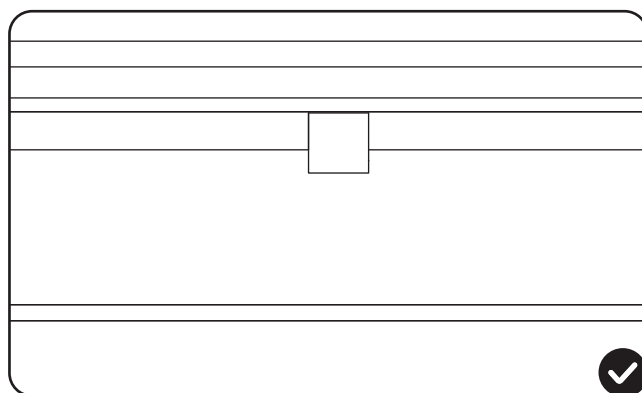
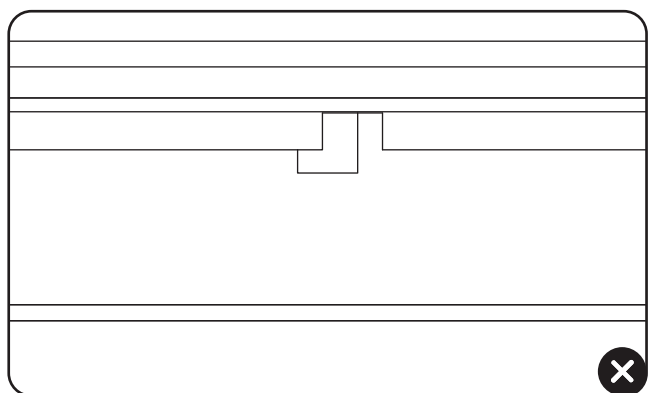
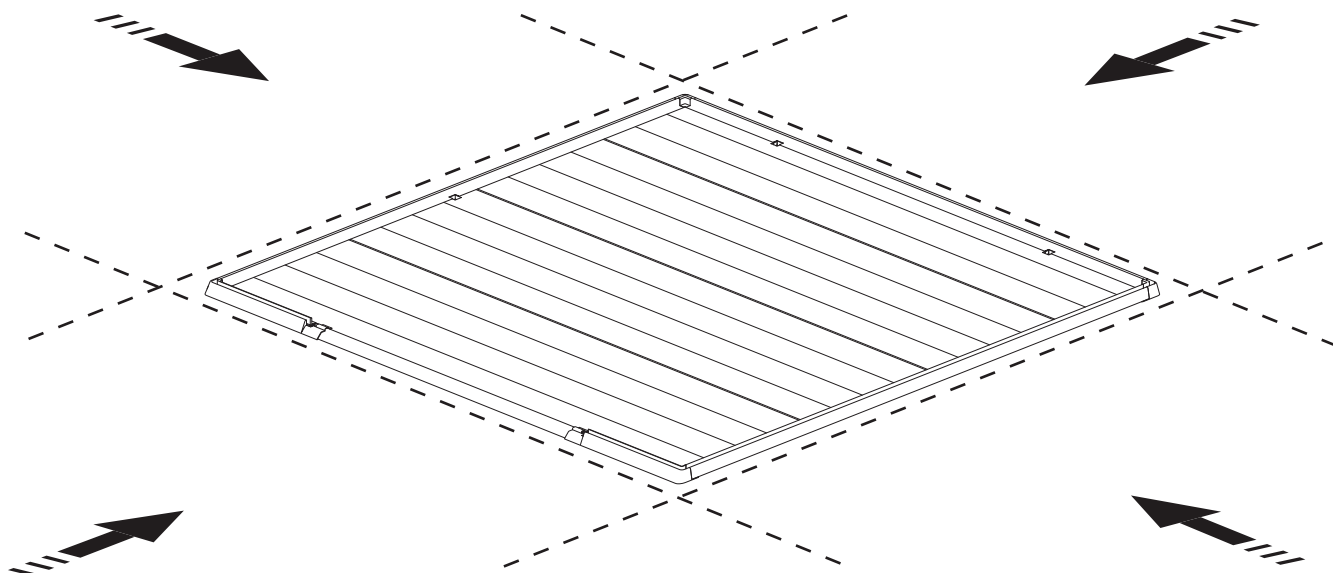

	KD083	x15
---	-------	-----

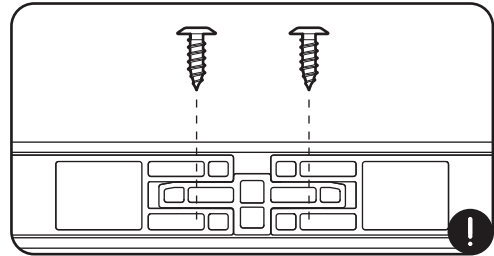
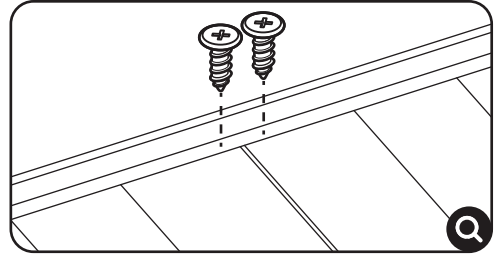
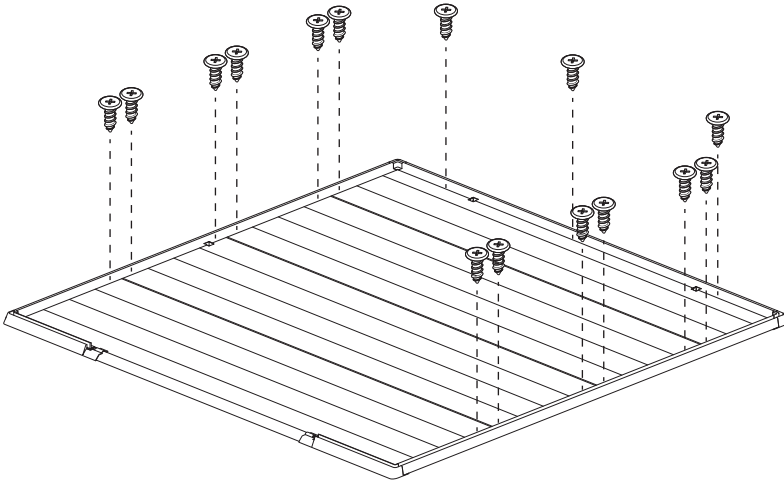

	KD083	x10
---	-------	-----

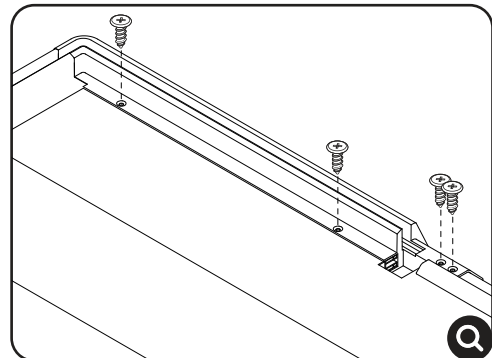
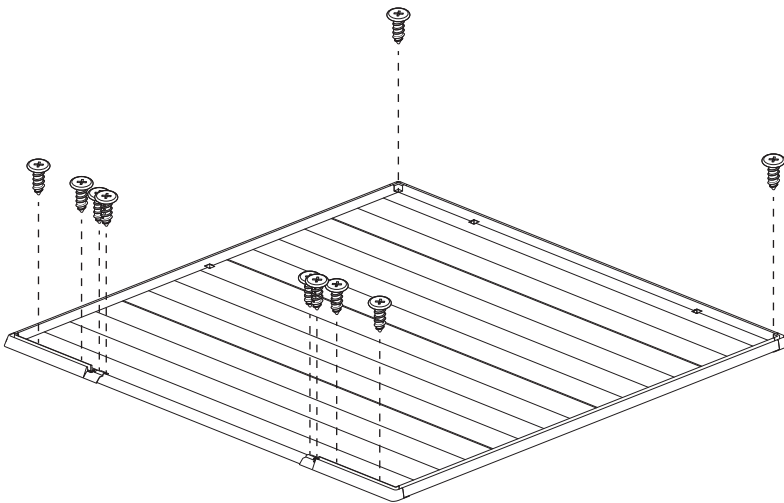

Assemblage du cadre

Frame Assembly

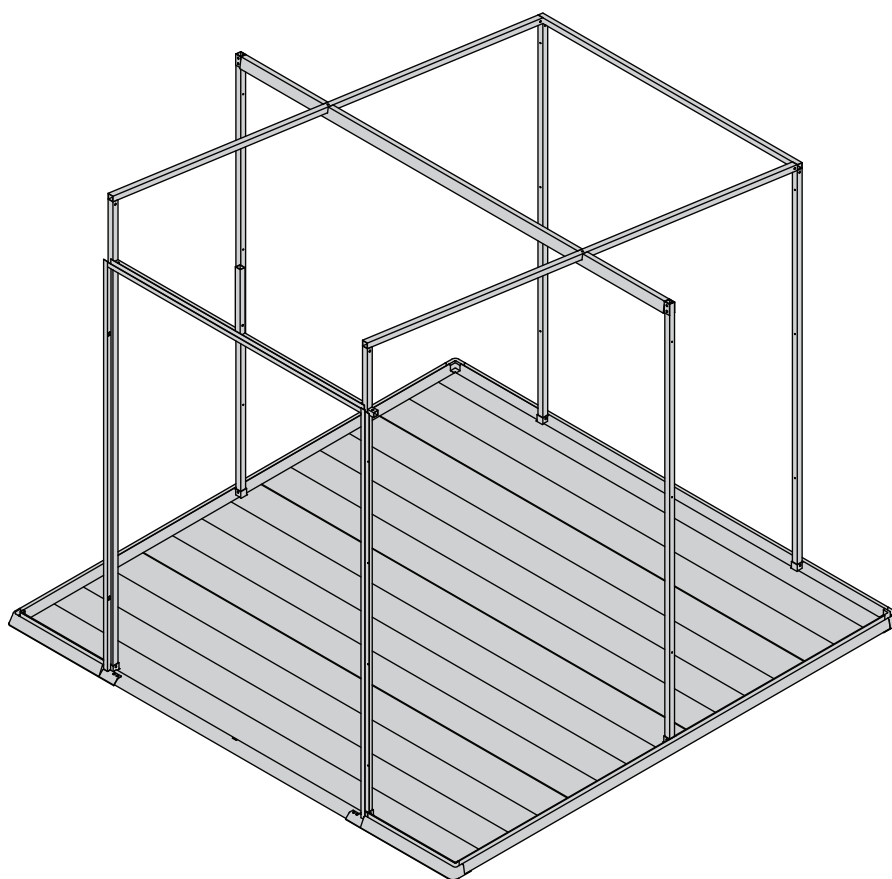

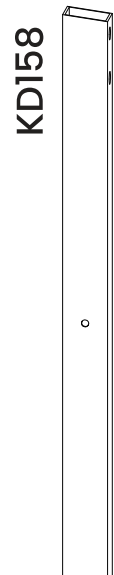

**Veillez noter le sens d'installation.
L'extrémité supérieure du tube carré doit être orientée vers le côté « avant ».**

Please note the installation direction.
The higher end of the square tube should face the "front" side.

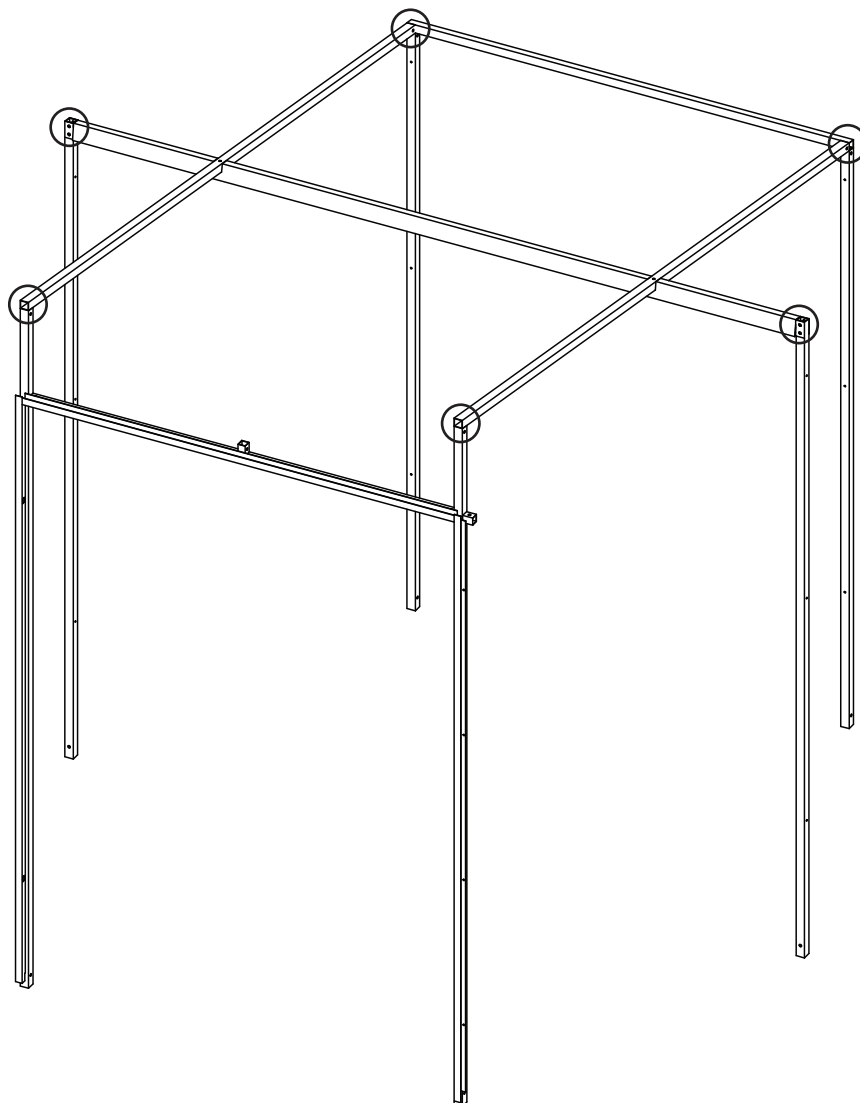

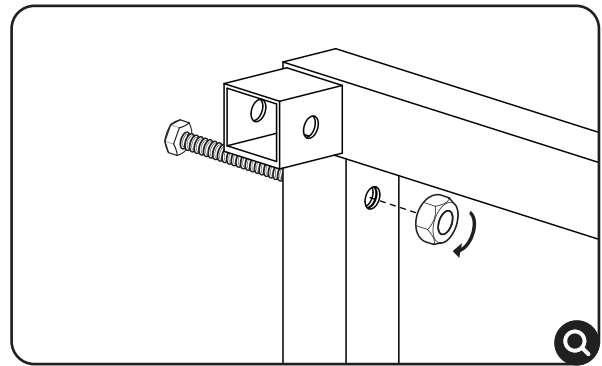
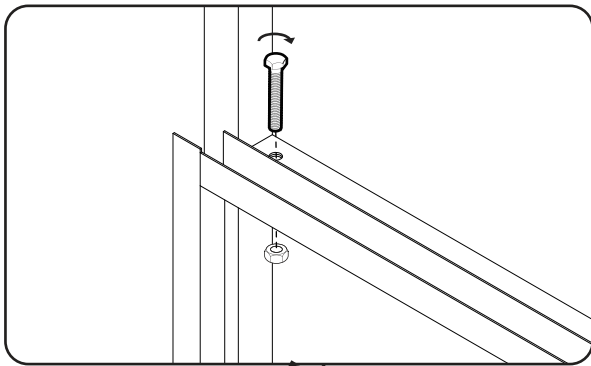
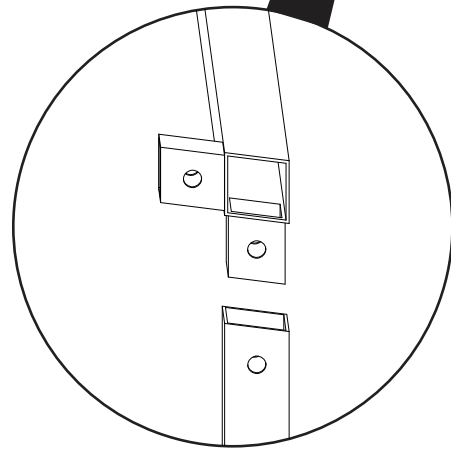
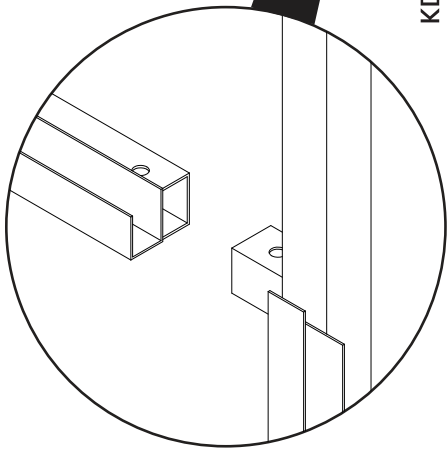
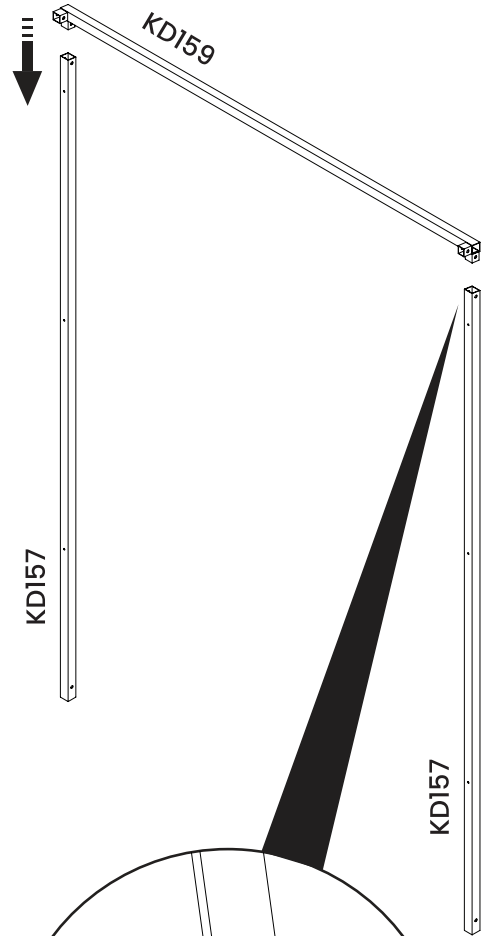
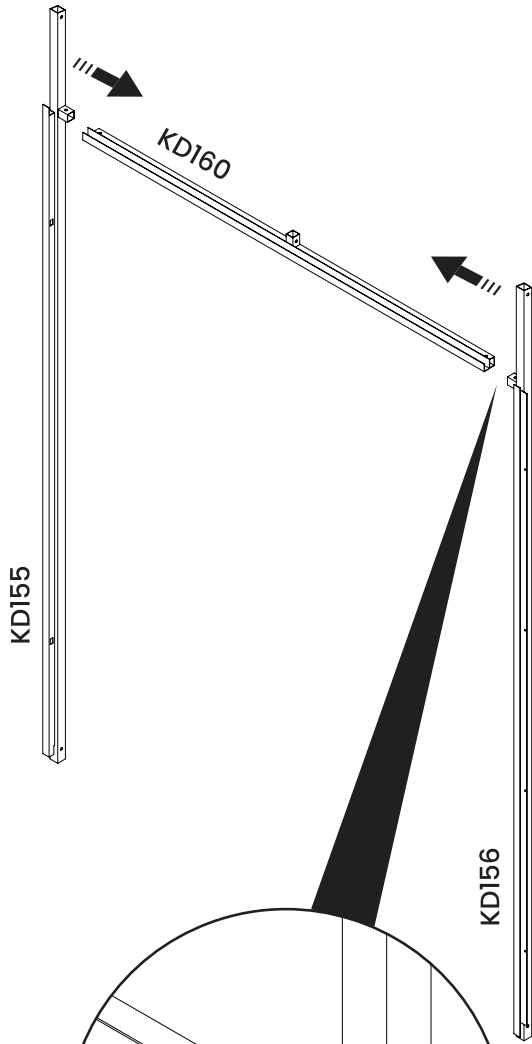
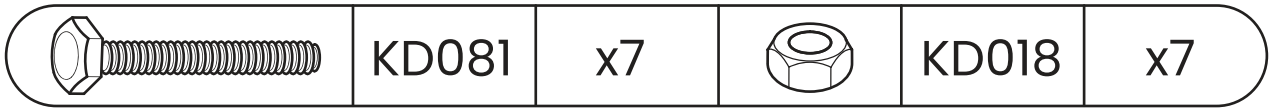

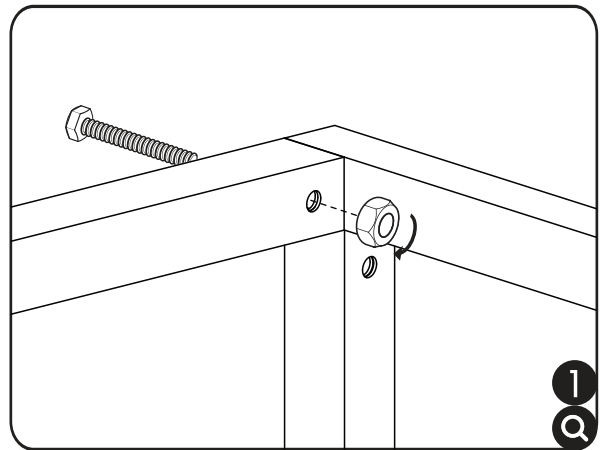
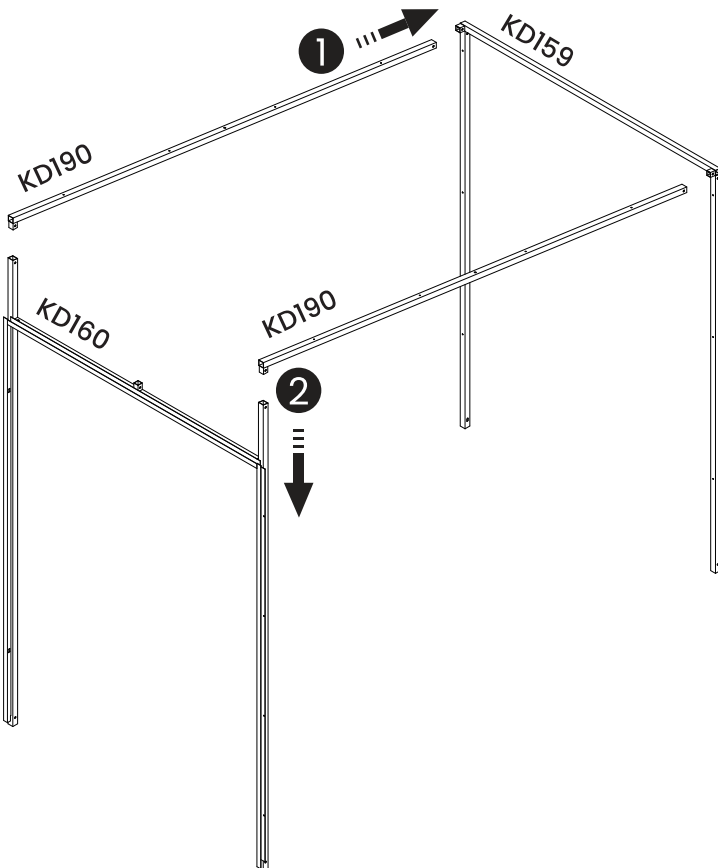
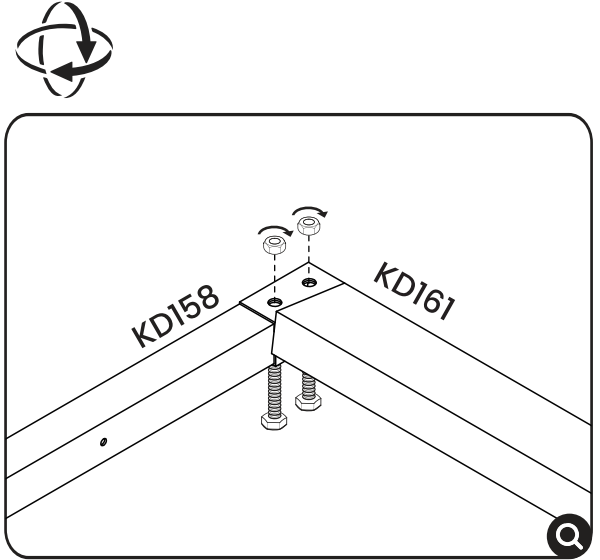
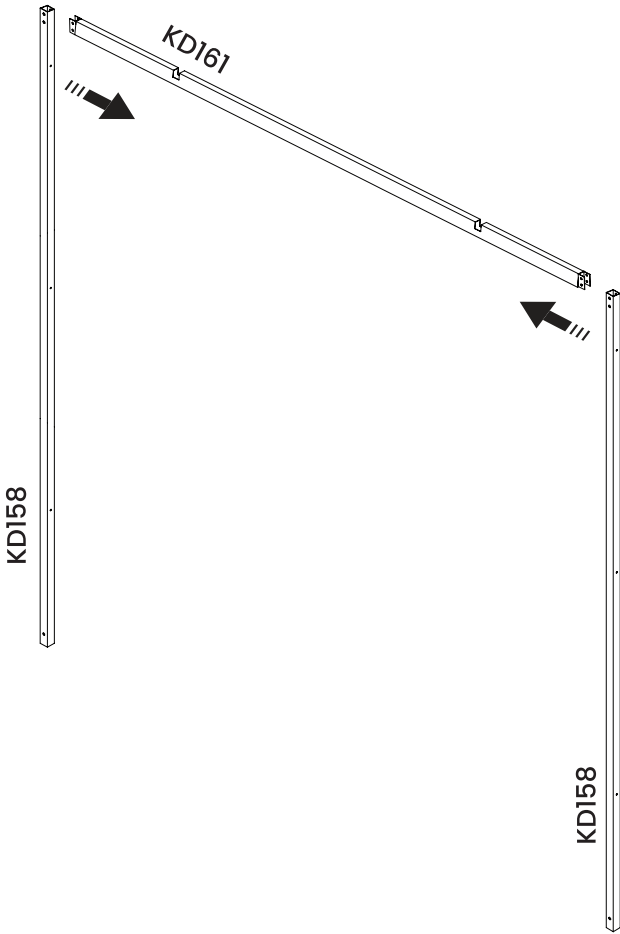
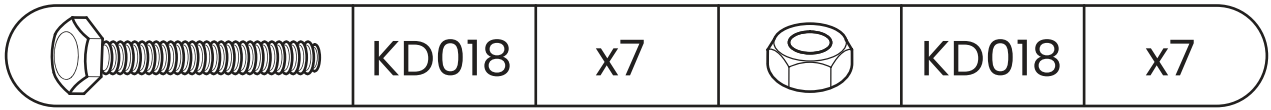

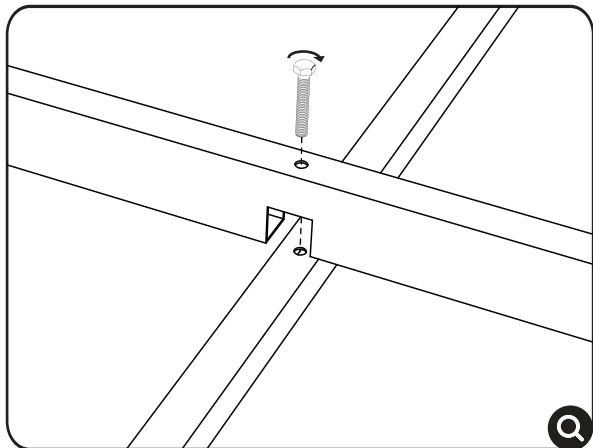
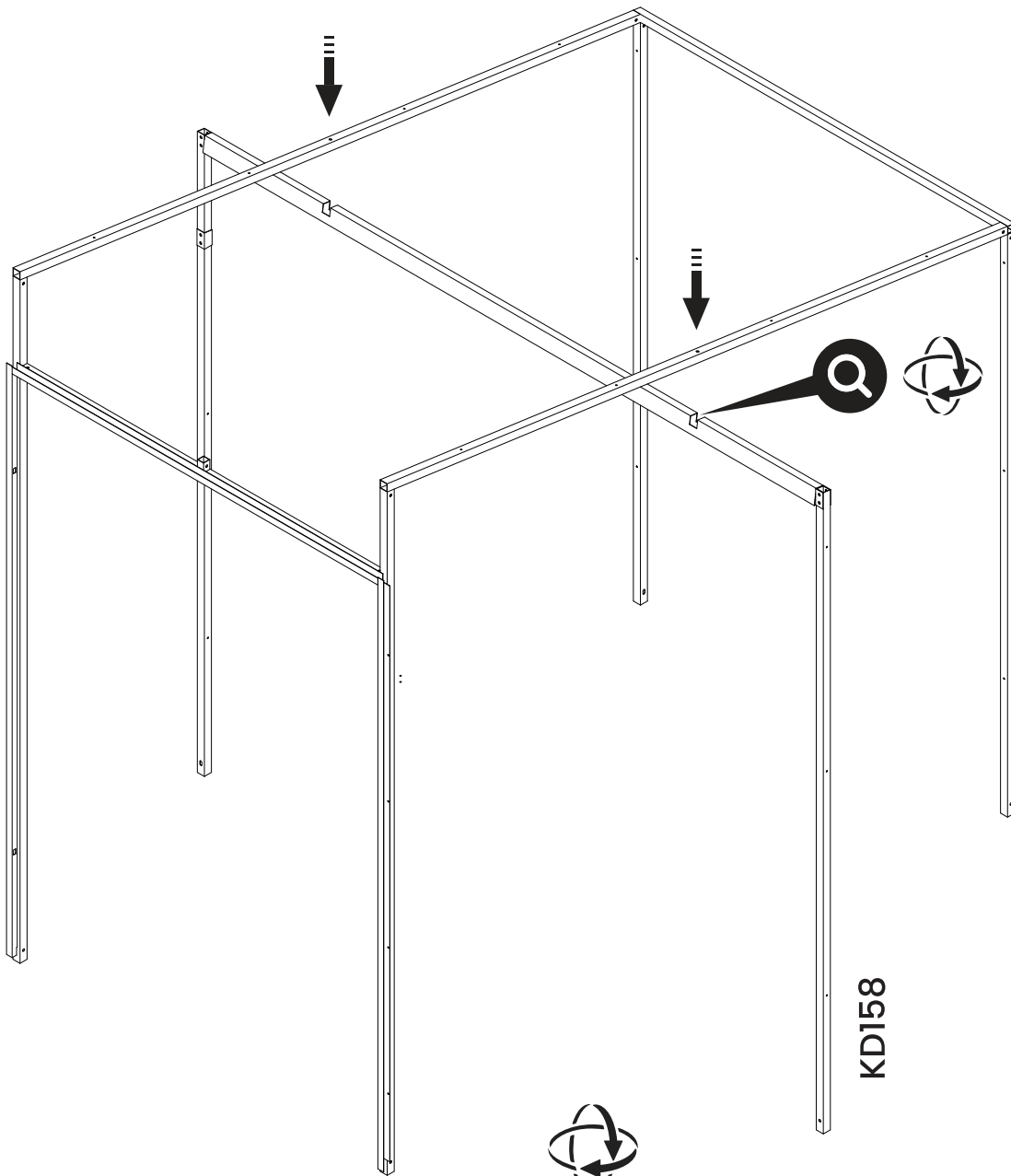

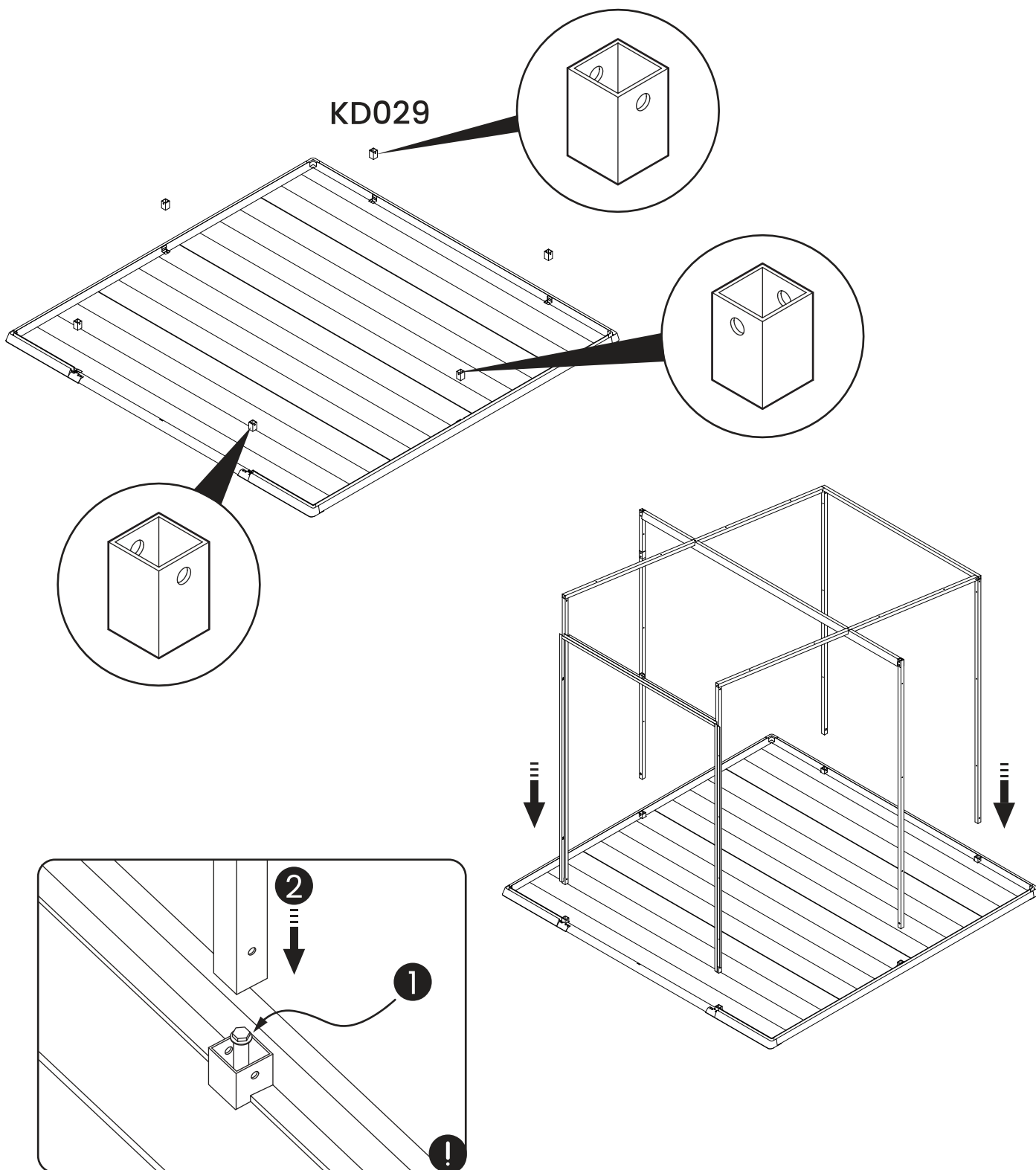

Si vous avez un sol en béton et que vous devez percer des trous pour les vis d'expansion, placez les fixations du cadre (KD029), marquez les positions en fonction des trous, puis utilisez une mèche pour percer les trous.

If you have a concrete floor and need to drill holes for expansion screws, please place the frame fixings (KD029), mark the positions according to the holes, and then use a drill bit to drill holes.

Option A

Plancher en bois / Wooden Floor

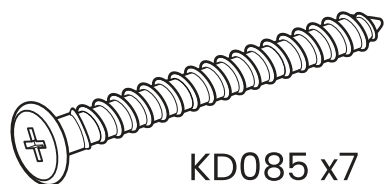

Retirer l'entretoise.
Take off the spacer.

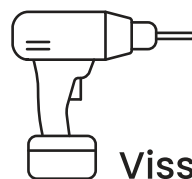
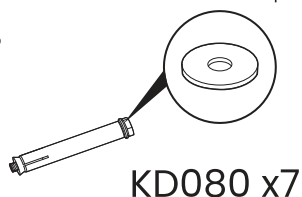

Visseuse
Screwdriver

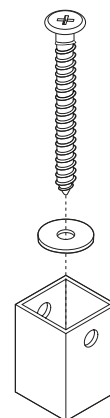

Option B

Sol en béton / Concrete Floor

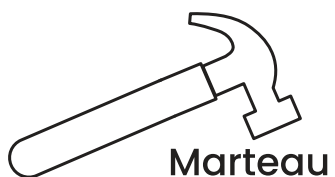
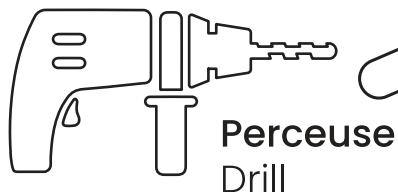
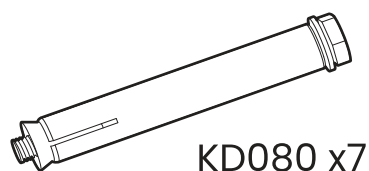

Après avoir placé les fixations du cadre au niveau des ouvertures du sol, utilisez une perceuse pour percer les trous en fonction de leur position.

After placing the frame fixings at the floor openings, use a drill bit to make holes according to the hole positions.

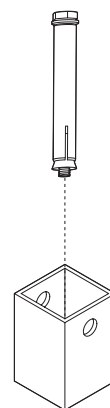

Option C

Sol / Soil Ground

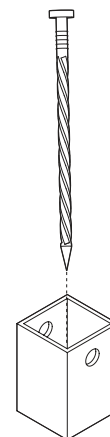
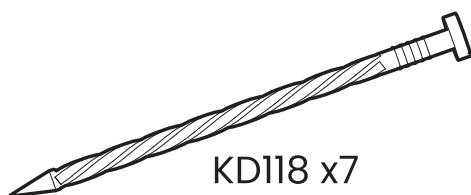

Veillez utiliser un outil approprié pour enfoncer le KD080 ou le KD118, mais nous avons également offert un KD080 supplémentaire pour ce faire.

Please use an appropriate tool to drive in the KD080 or the KD118, however we also offered an extra KD080 to do that.

Que vous choisissiez l'option A, B ou C, ne verrouillez pas le KD029 à ce stade !

Whether you select option A, B, or C, please do not lock KD029 at this step!

Assemblage des murs

Wall Assembly

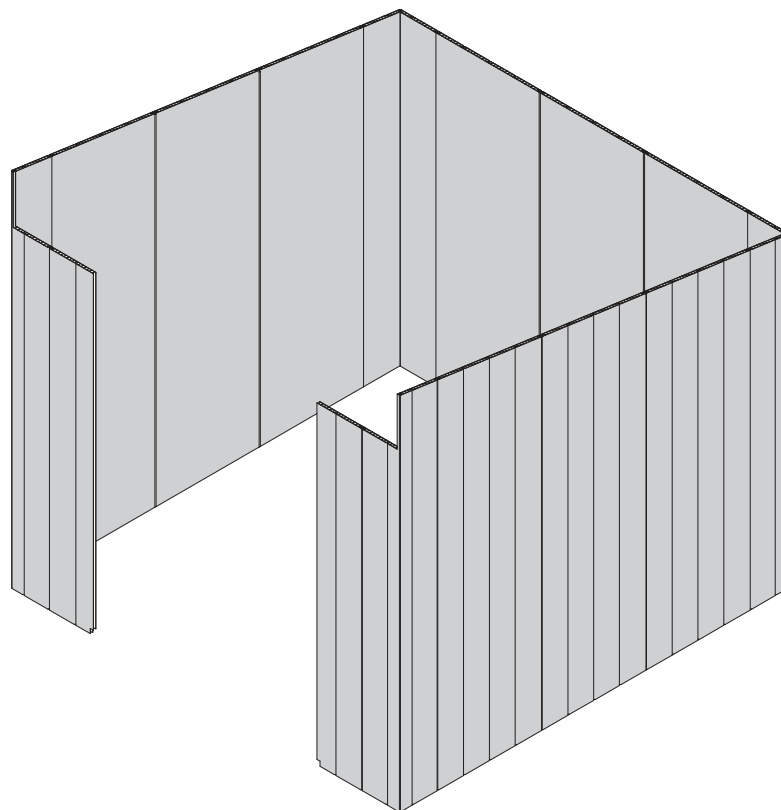

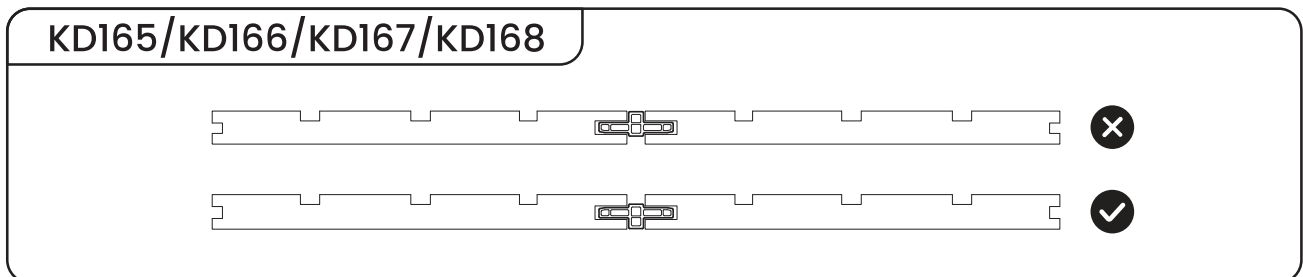
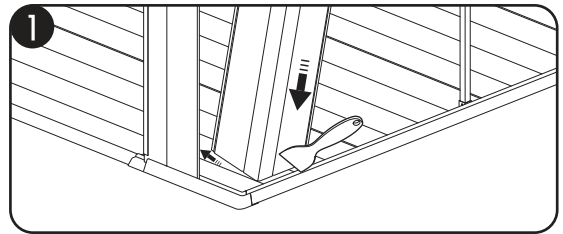
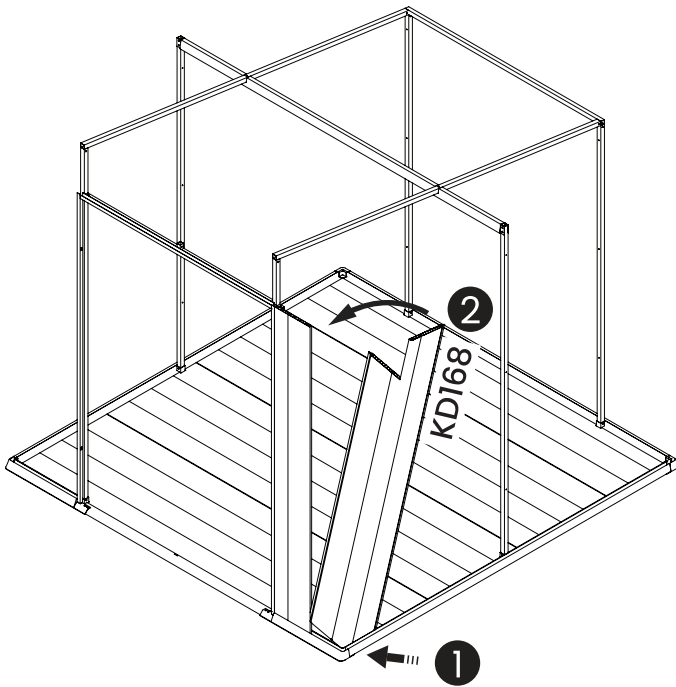
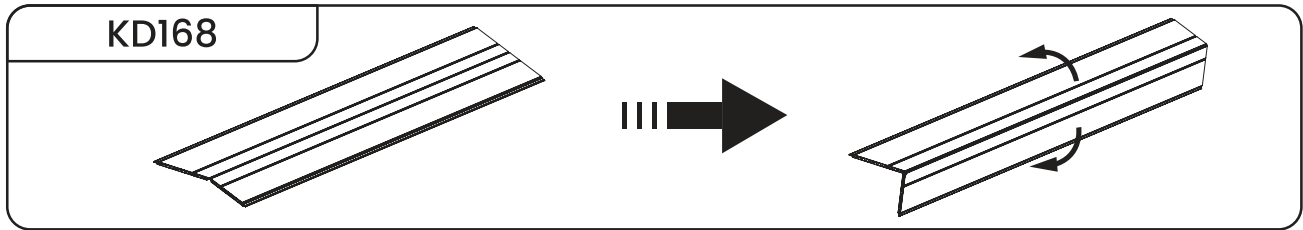
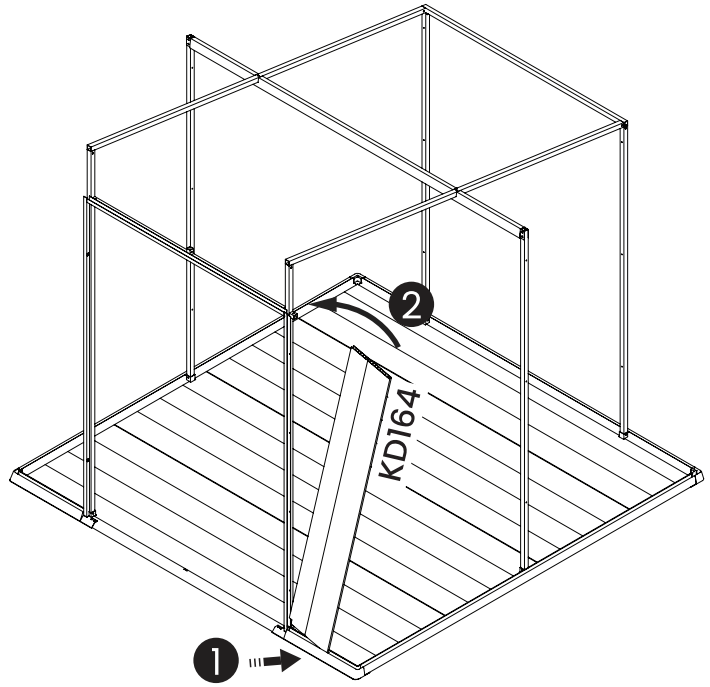
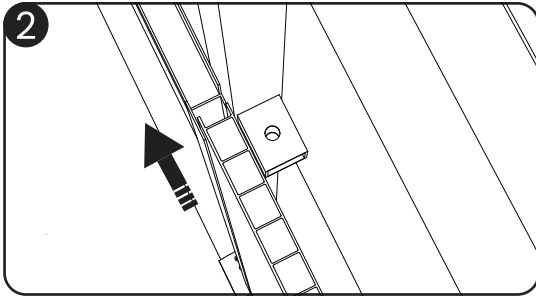
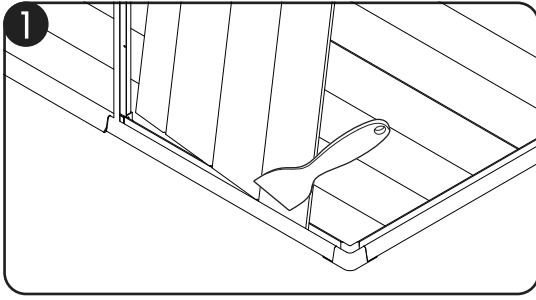

Étape 1 / Step 1

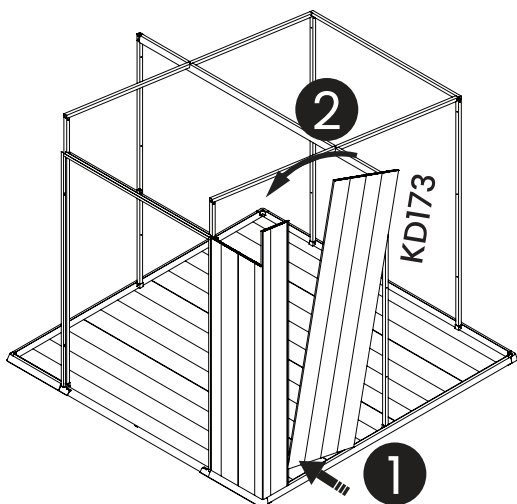

Étape 2 / Step 2

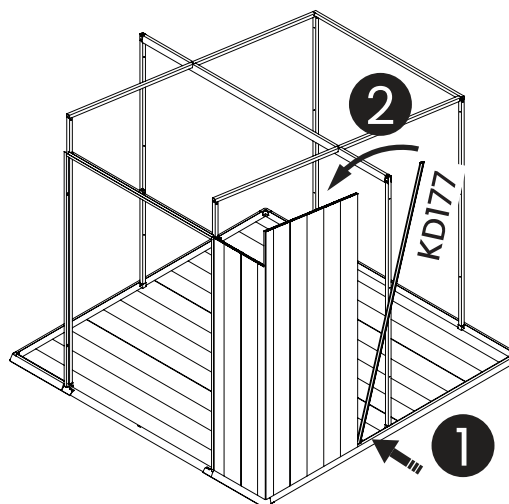

Étape 3 / Step 3

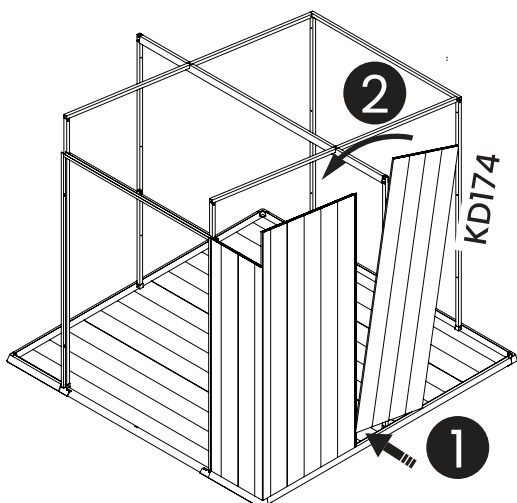

Étape 4 / Step 4

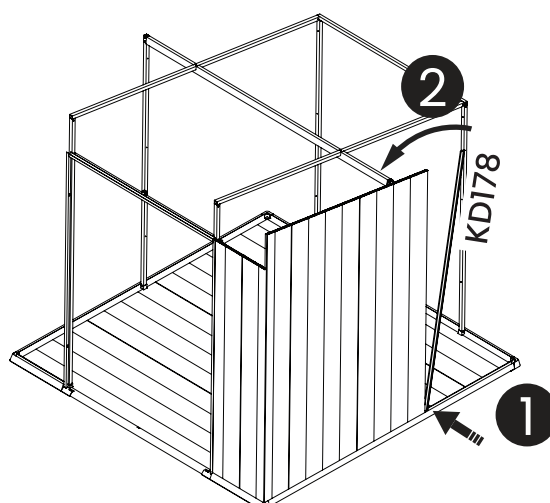

Étape 5 / Step 5

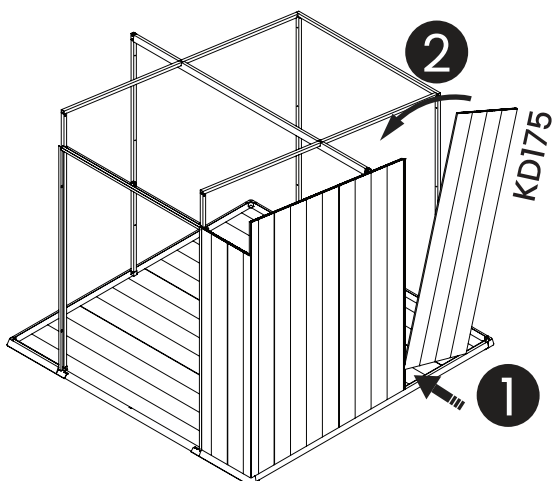

Étape 6 / Step 6

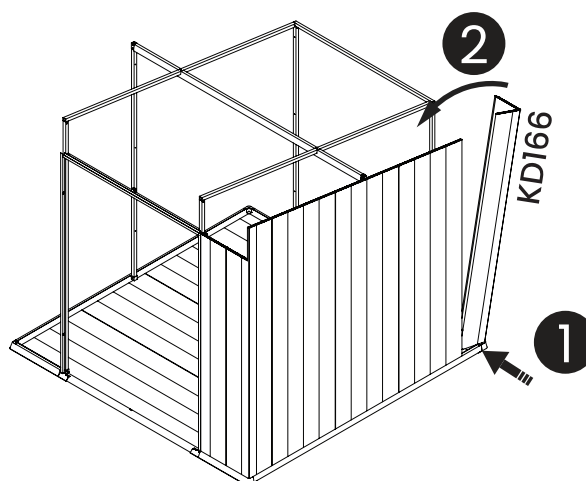

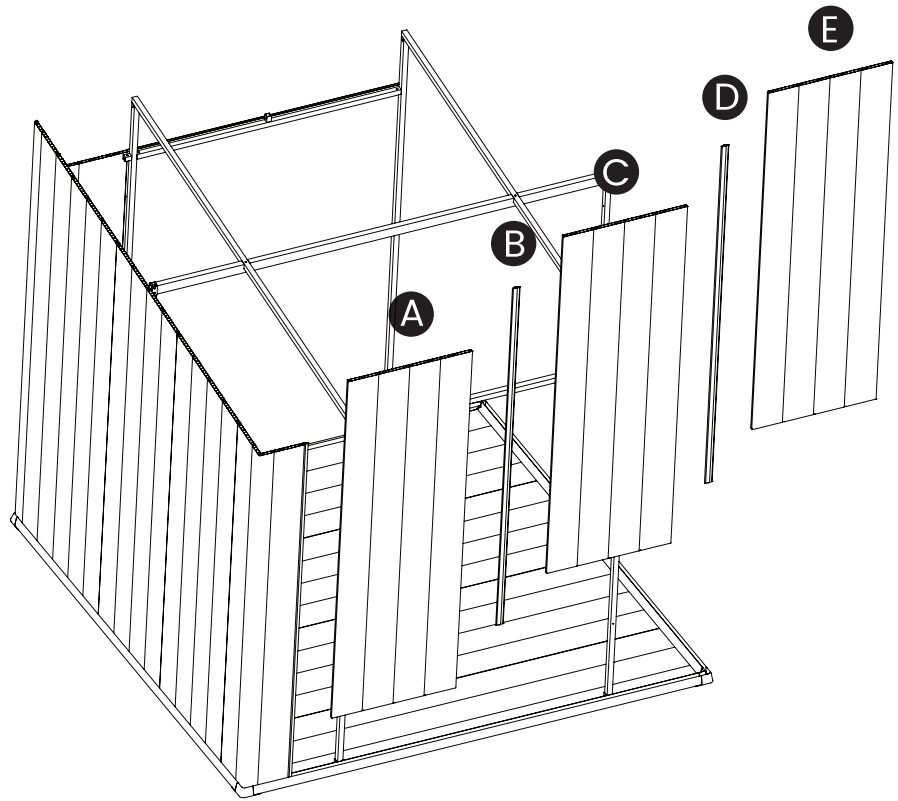
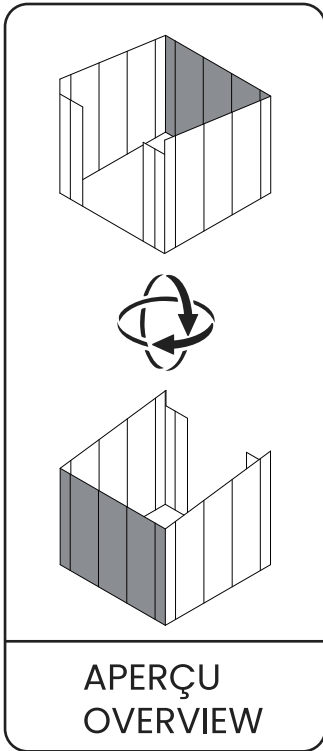

A C E KD169

B D KD176

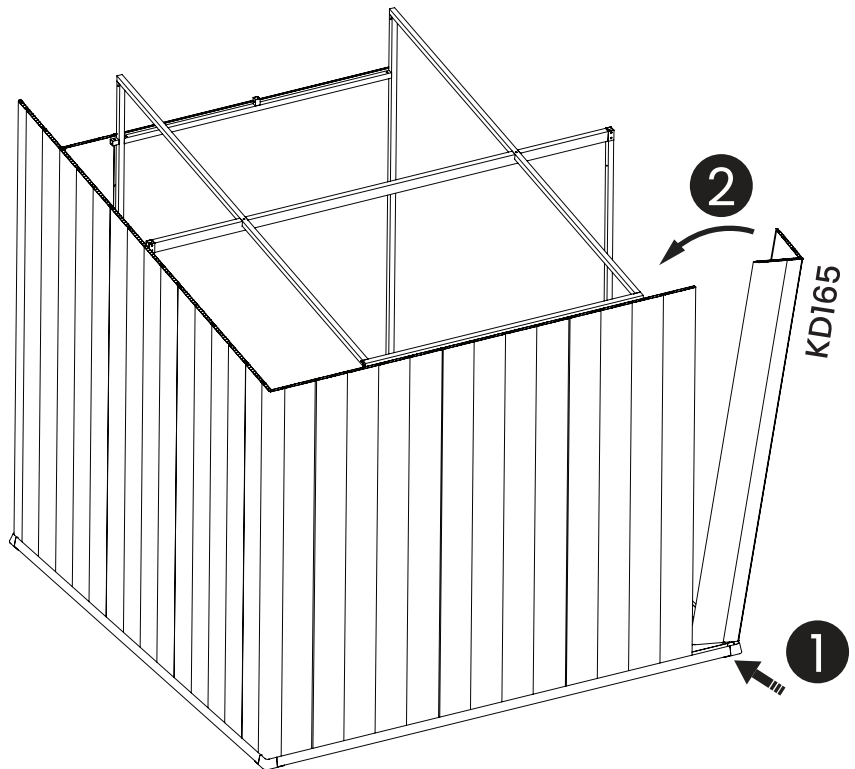
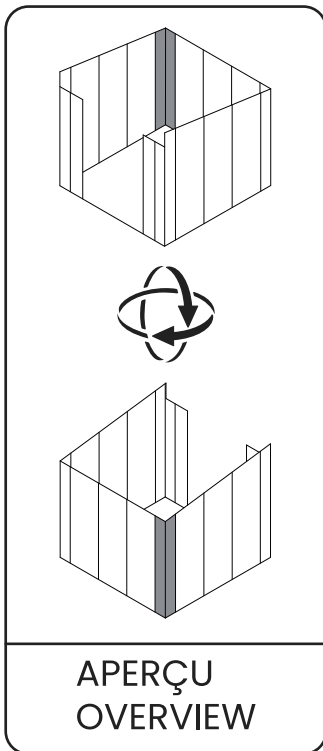

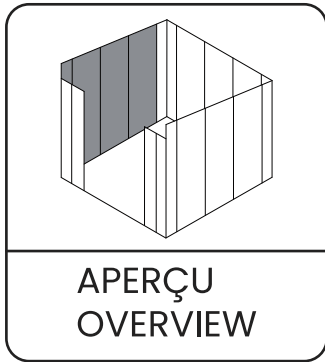

- A** KDI70
- B** KDI77
- C** KDI71
- D** KDI78
- E** KDI72

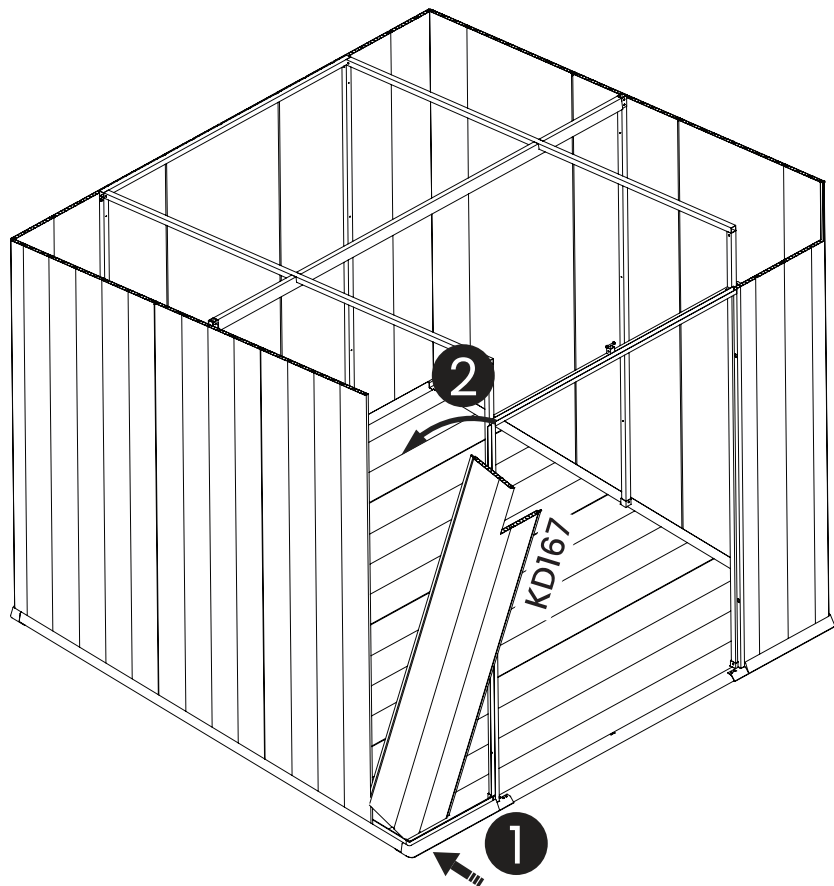
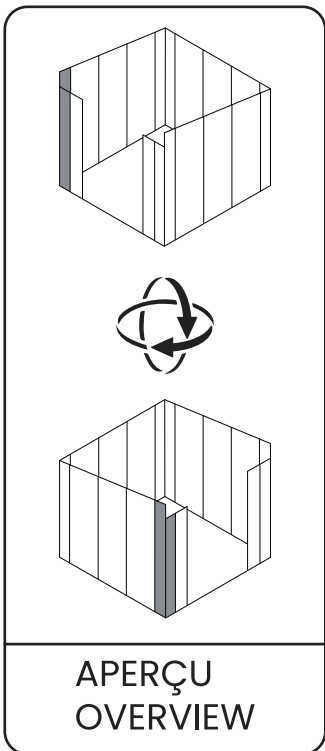
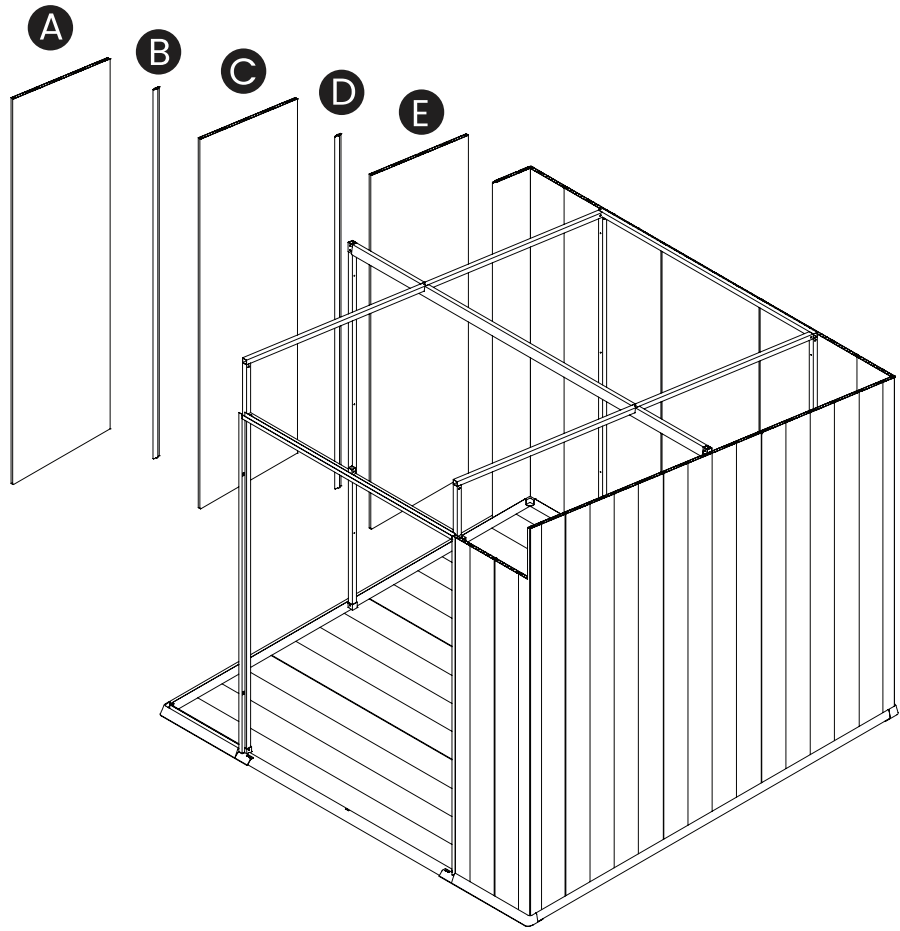

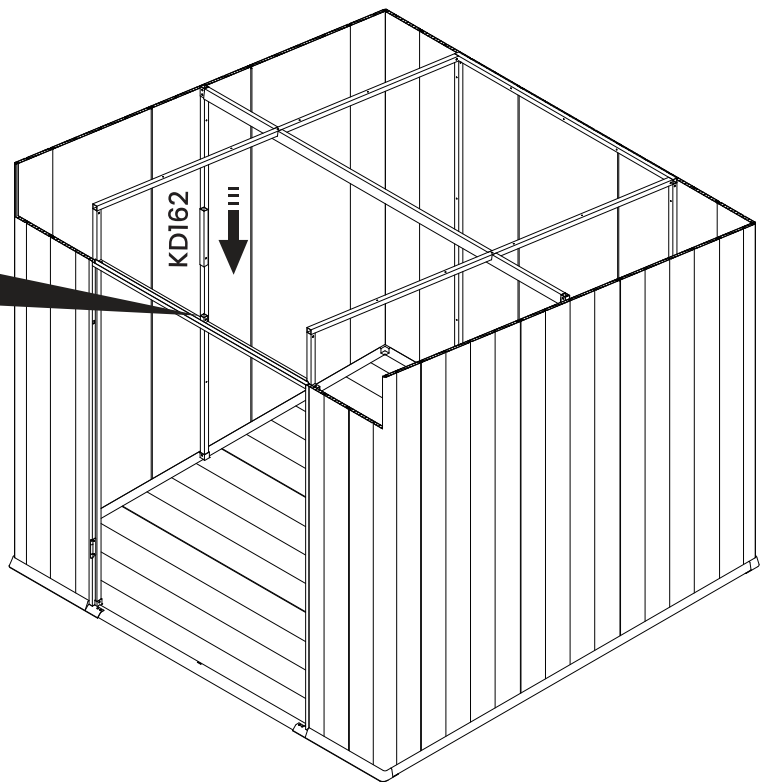
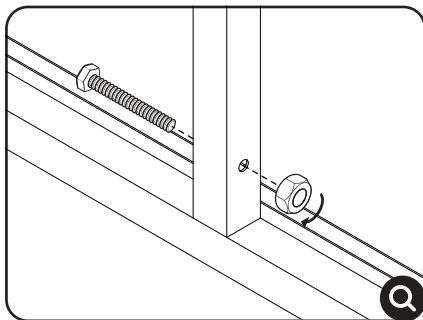
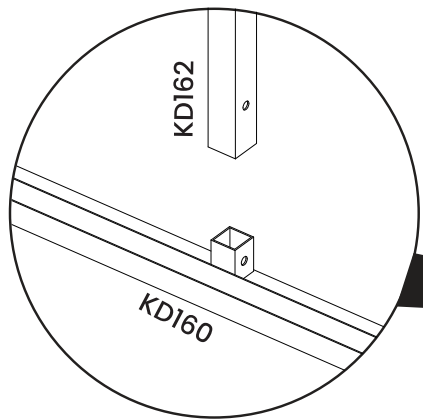
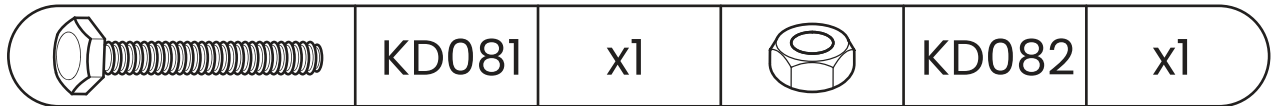
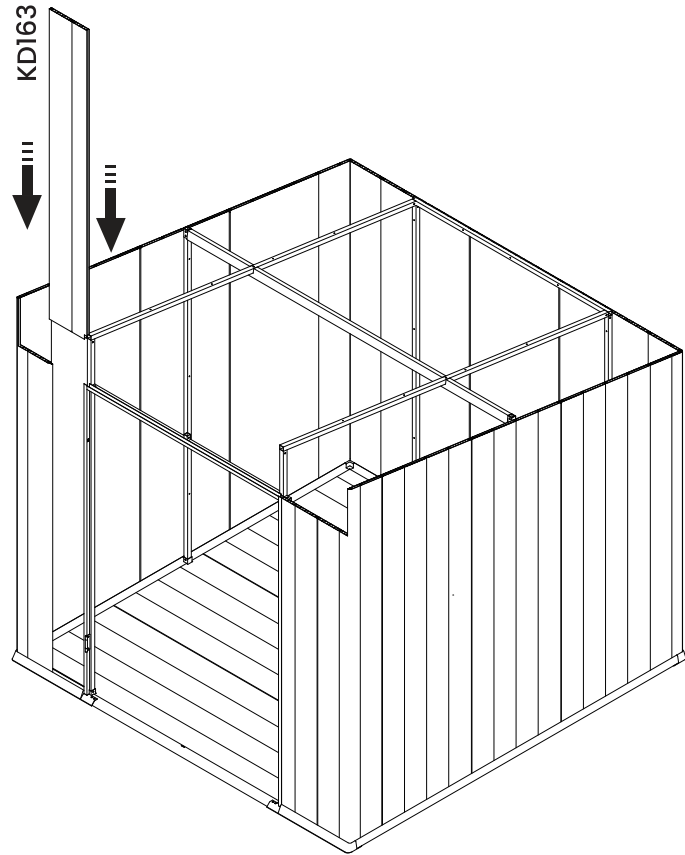
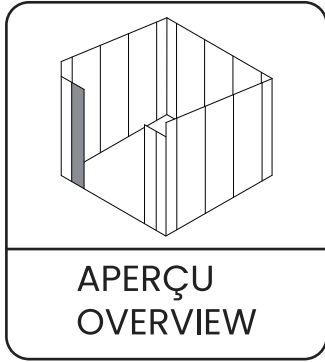

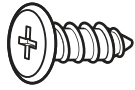

KD083

x18

Il n'y a pas d'avant-trou proposé. Respectez la distance moyenne.
There is no pre-drill hole offered. Keep the distance averagely.

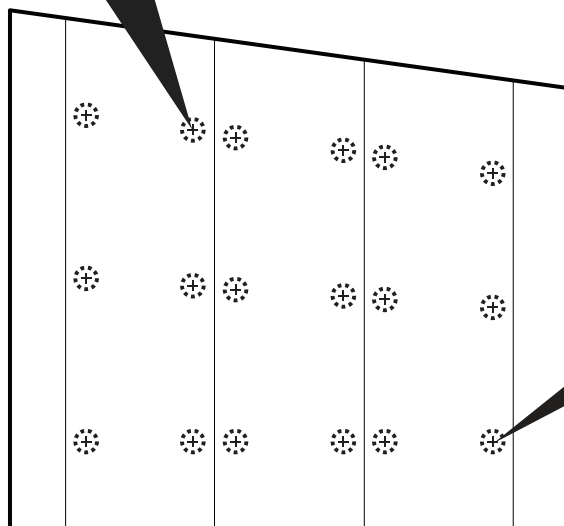
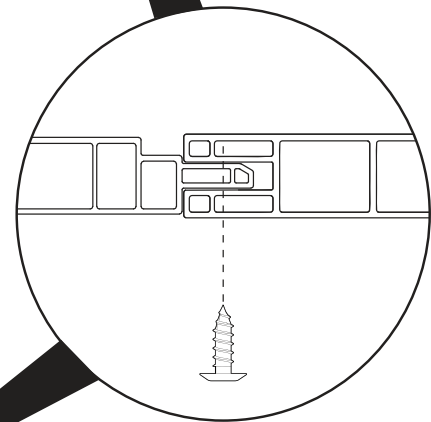
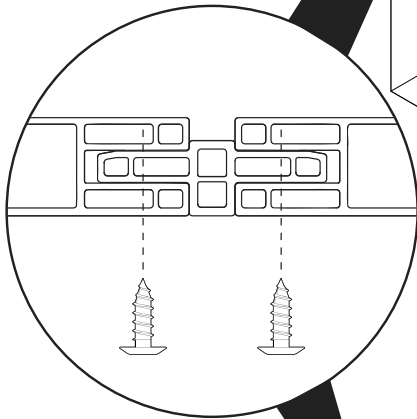
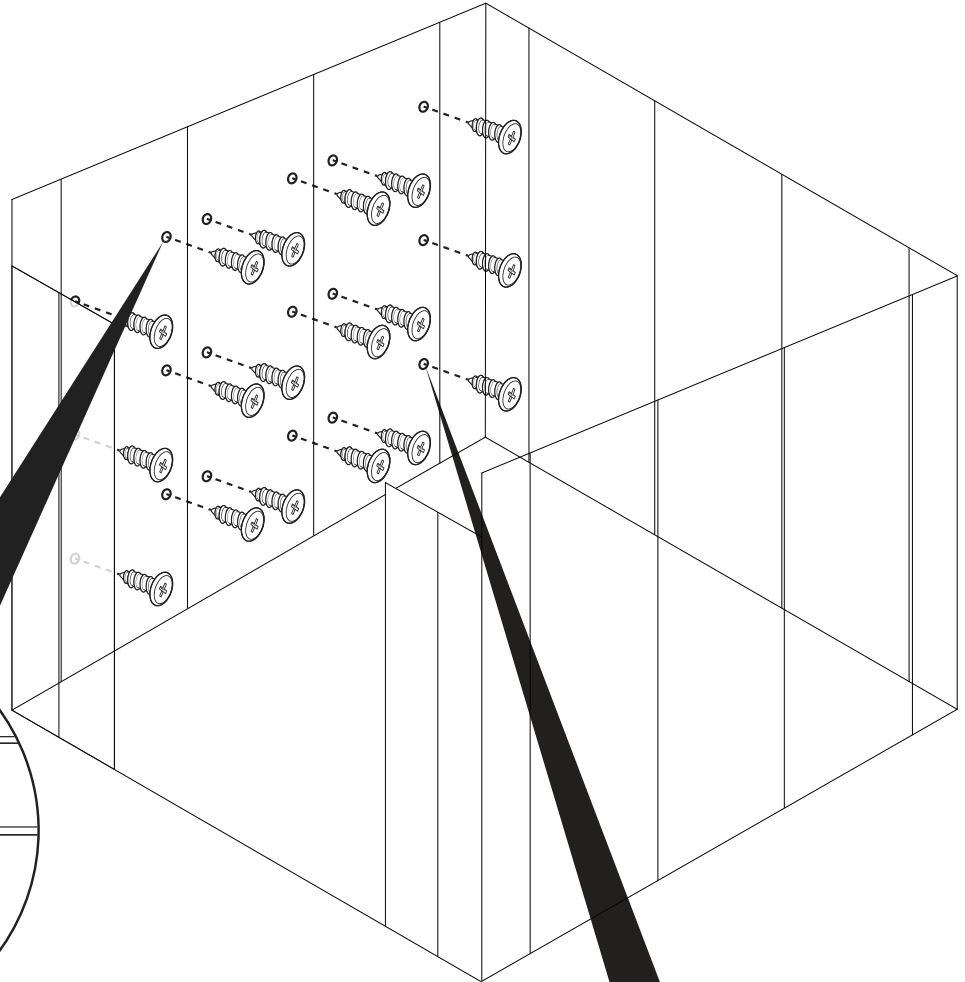
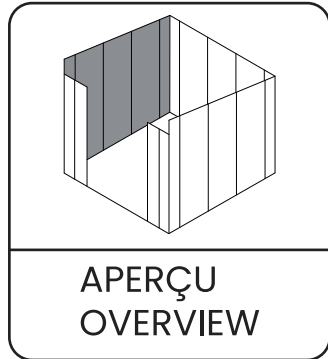

Vue intérieur projetée / Inside Projected View



KD083

x18

Il n'y a pas d'avant-trou proposé. Respectez la distance moyennement.
There is no pre-drill hole offered. Keep the distance averagely.

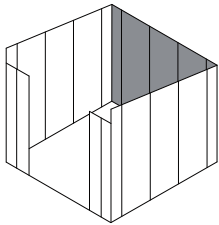

APERÇU
OVERVIEW

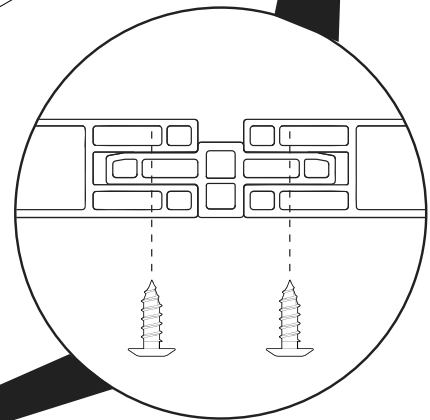
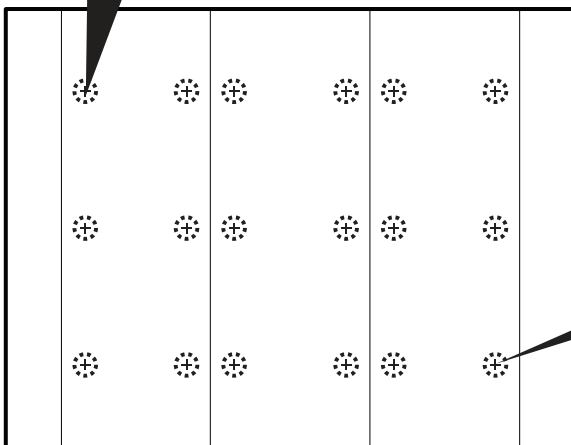
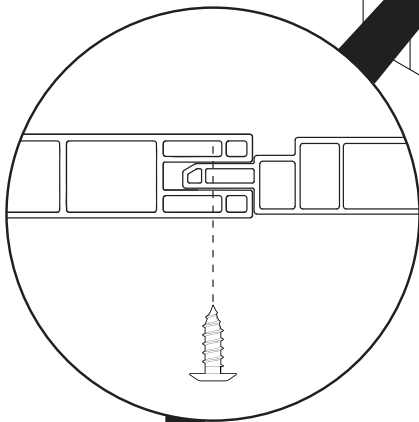
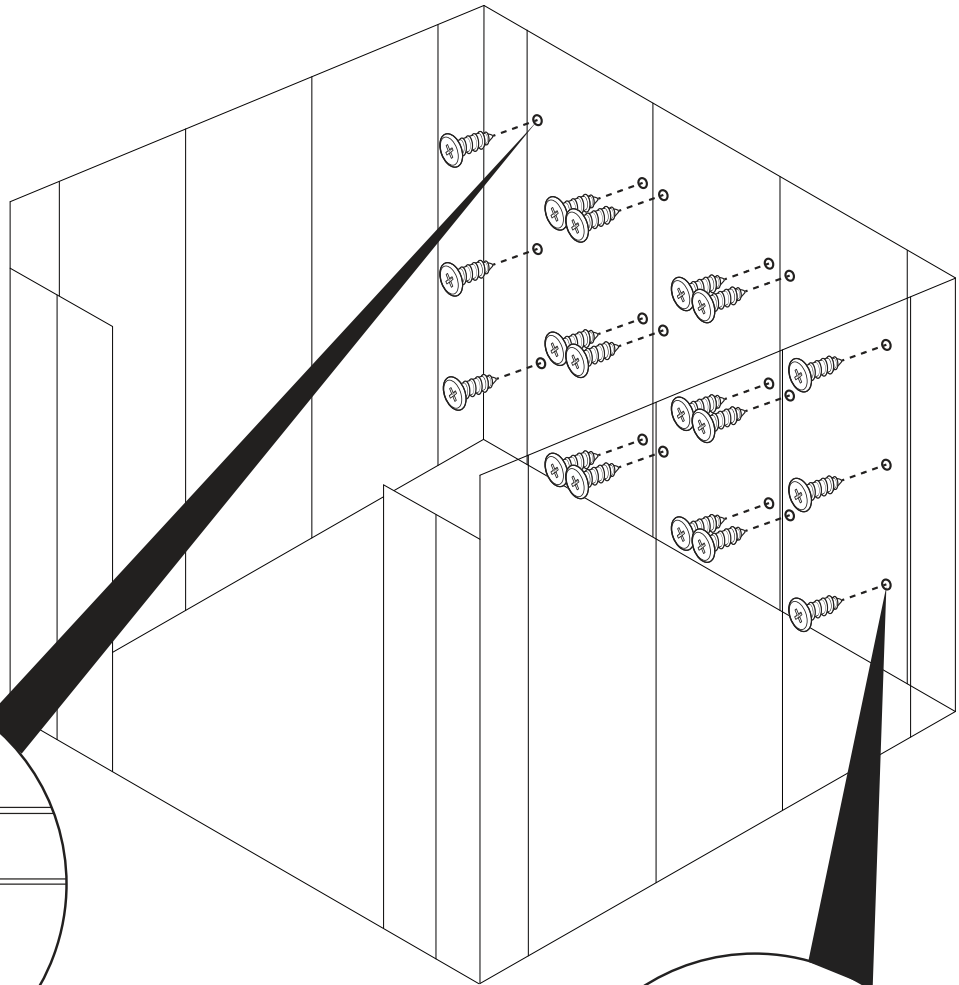

Vue intérieur projetée / Inside Projected View

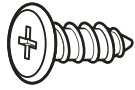

KD083

x18

Il n'y a pas d'avant-trou proposé. Respectez la distance moyenne.
There is no pre-drill hole offered. Keep the distance averagely.

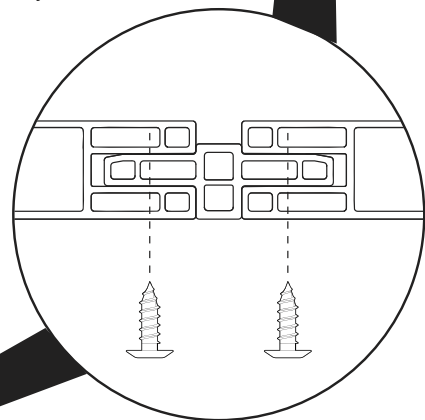
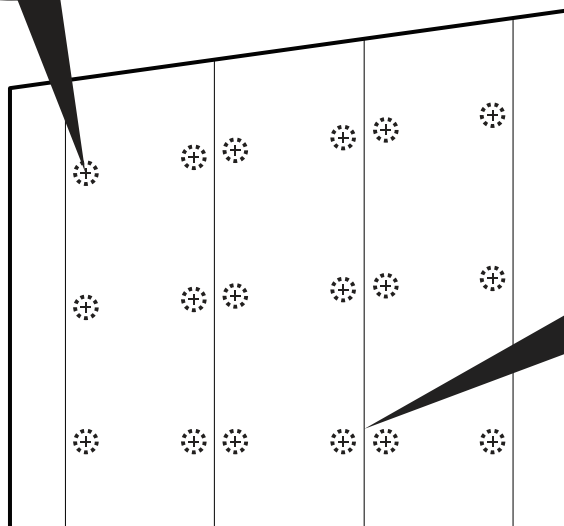
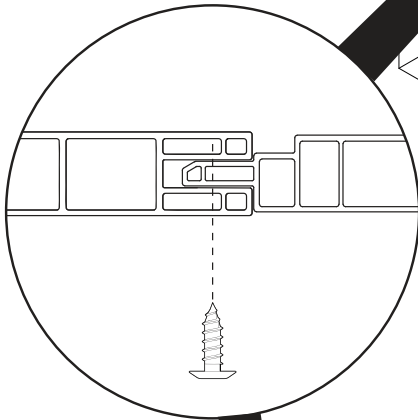
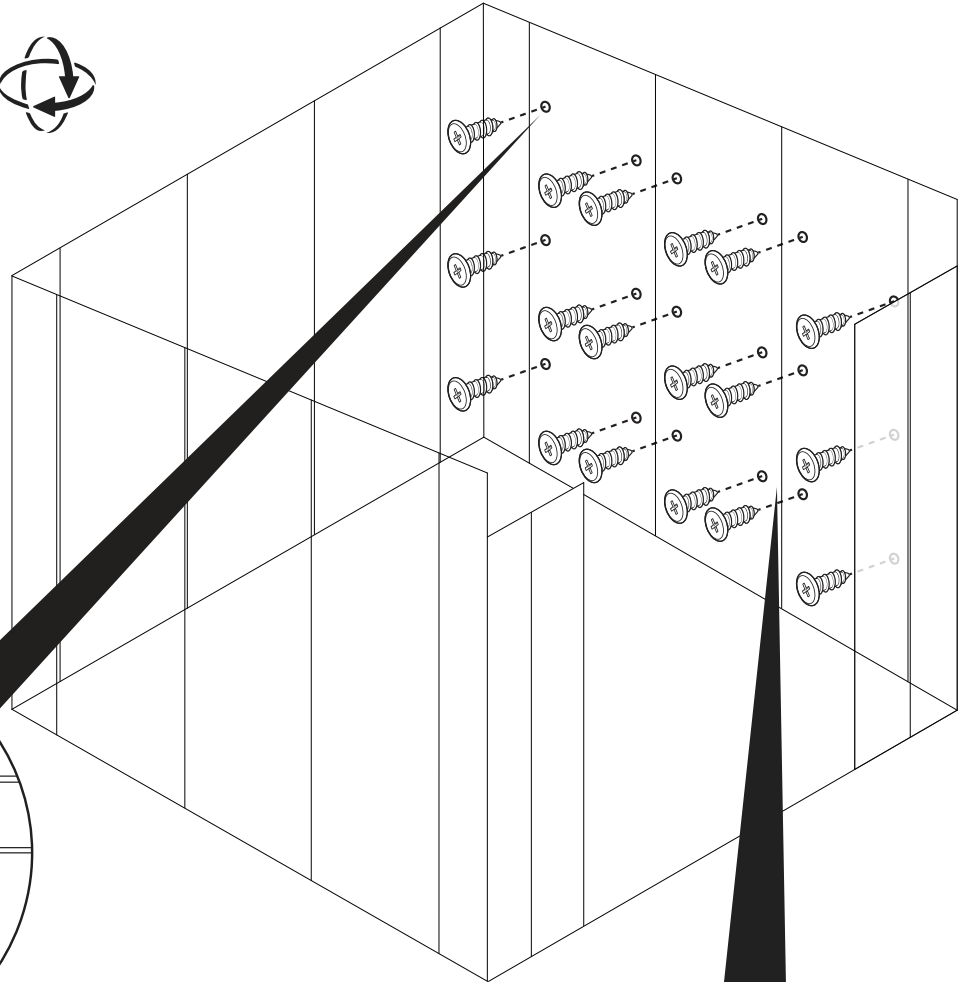
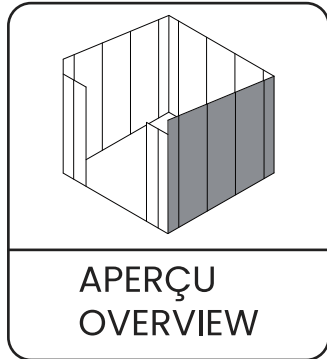

Vue intérieur projetée / Inside Projected View

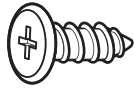

KD083

x14

Aucun pré-trou n'est proposé. Respectez la distance moyenne.
There is no pre-drill hole offered. Keep the distance averagely.

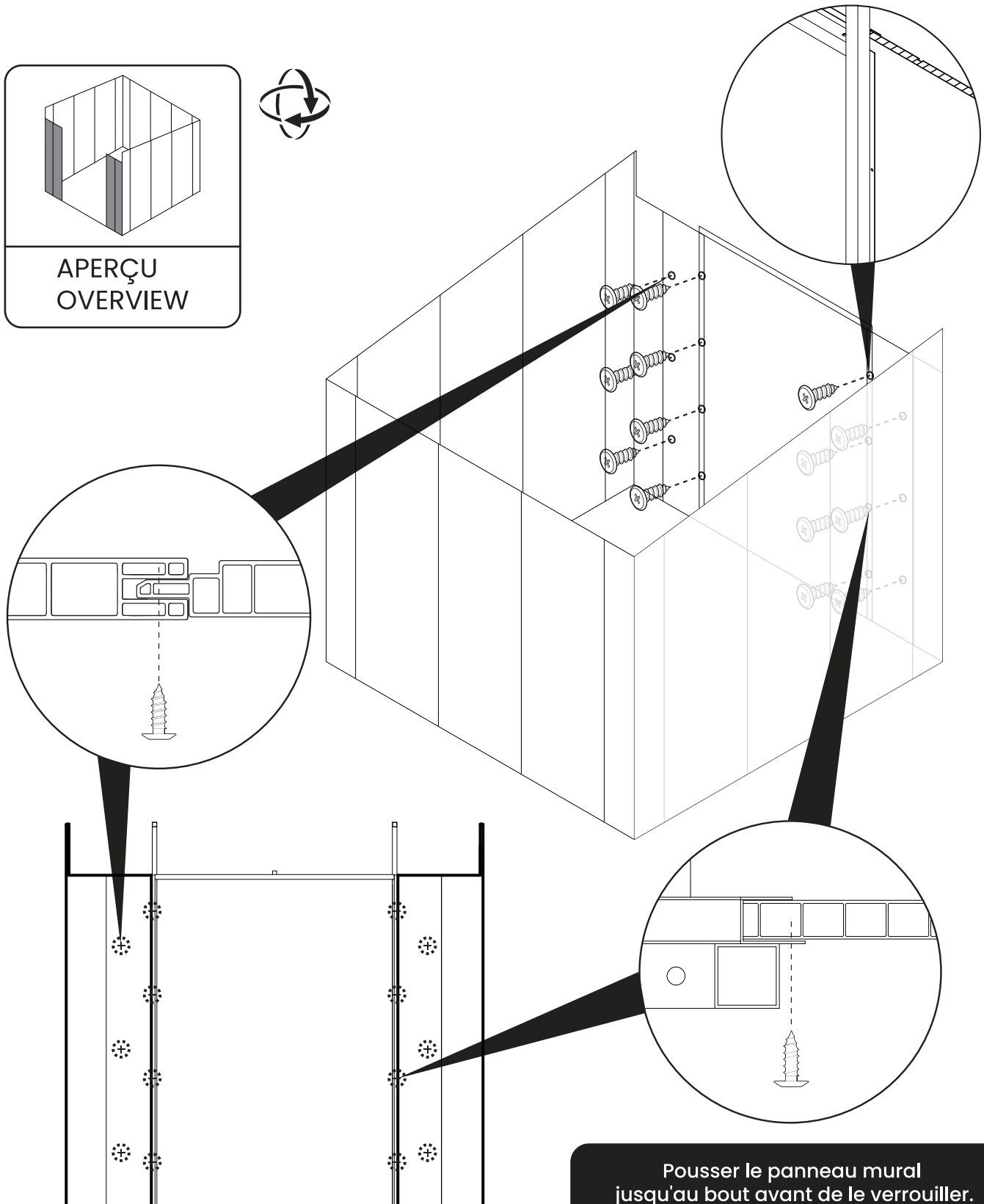
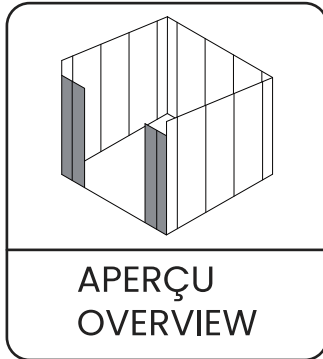

Pousser le panneau mural jusqu'au bout avant de le verrouiller.
Push the wall panel to the end before locking.

Assemblage de fenêtre

Window Assembly

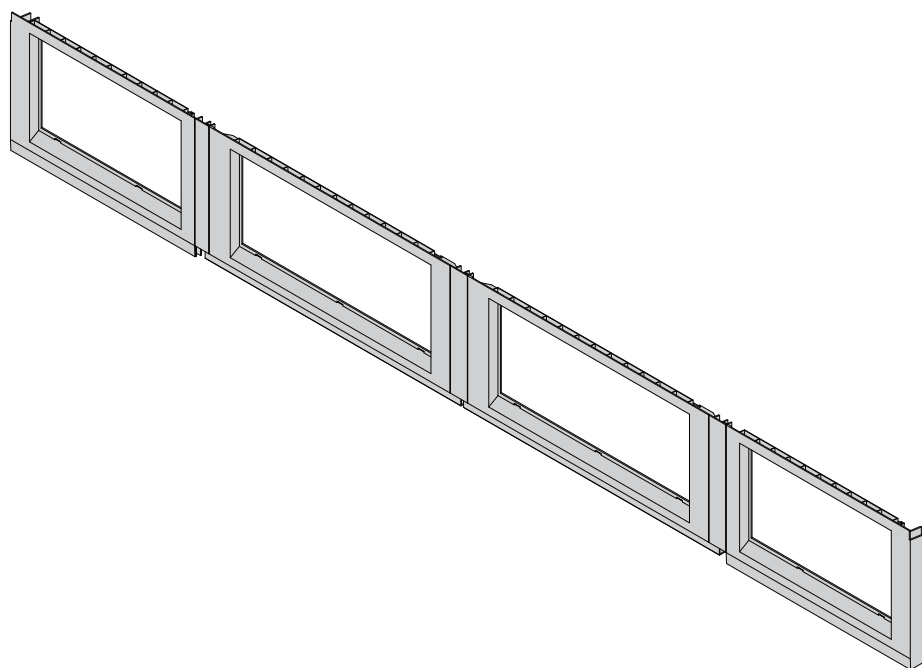

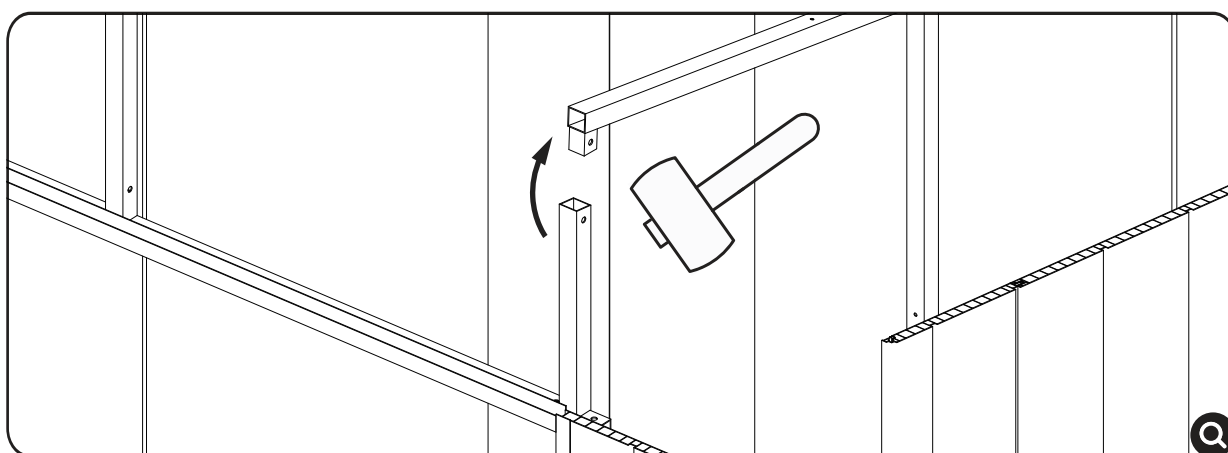
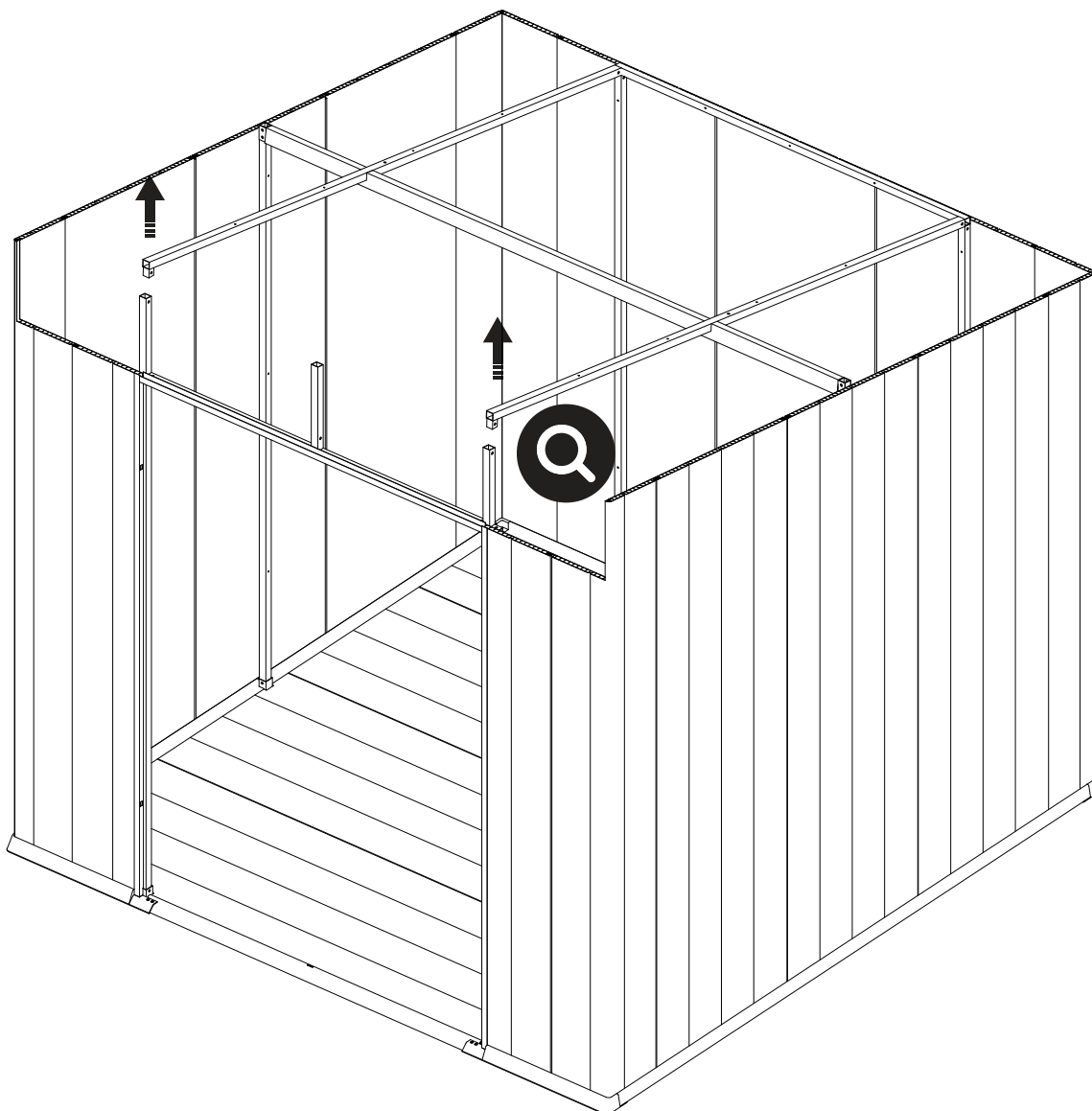

SÉPARATION / SEPARATE

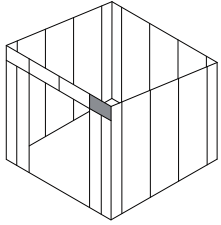

APERÇU
OVERVIEW

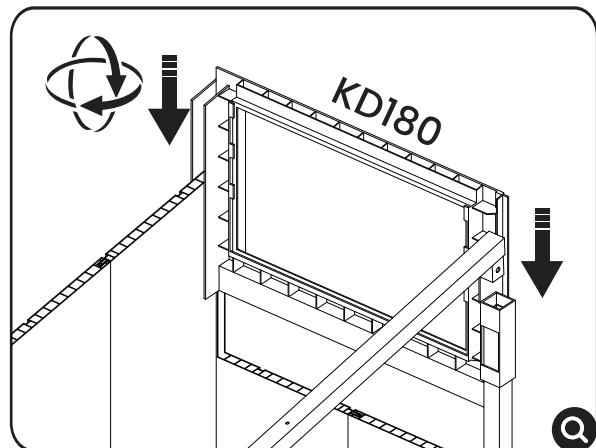
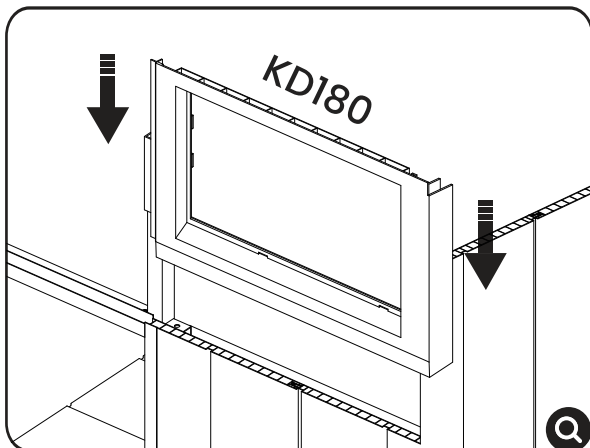
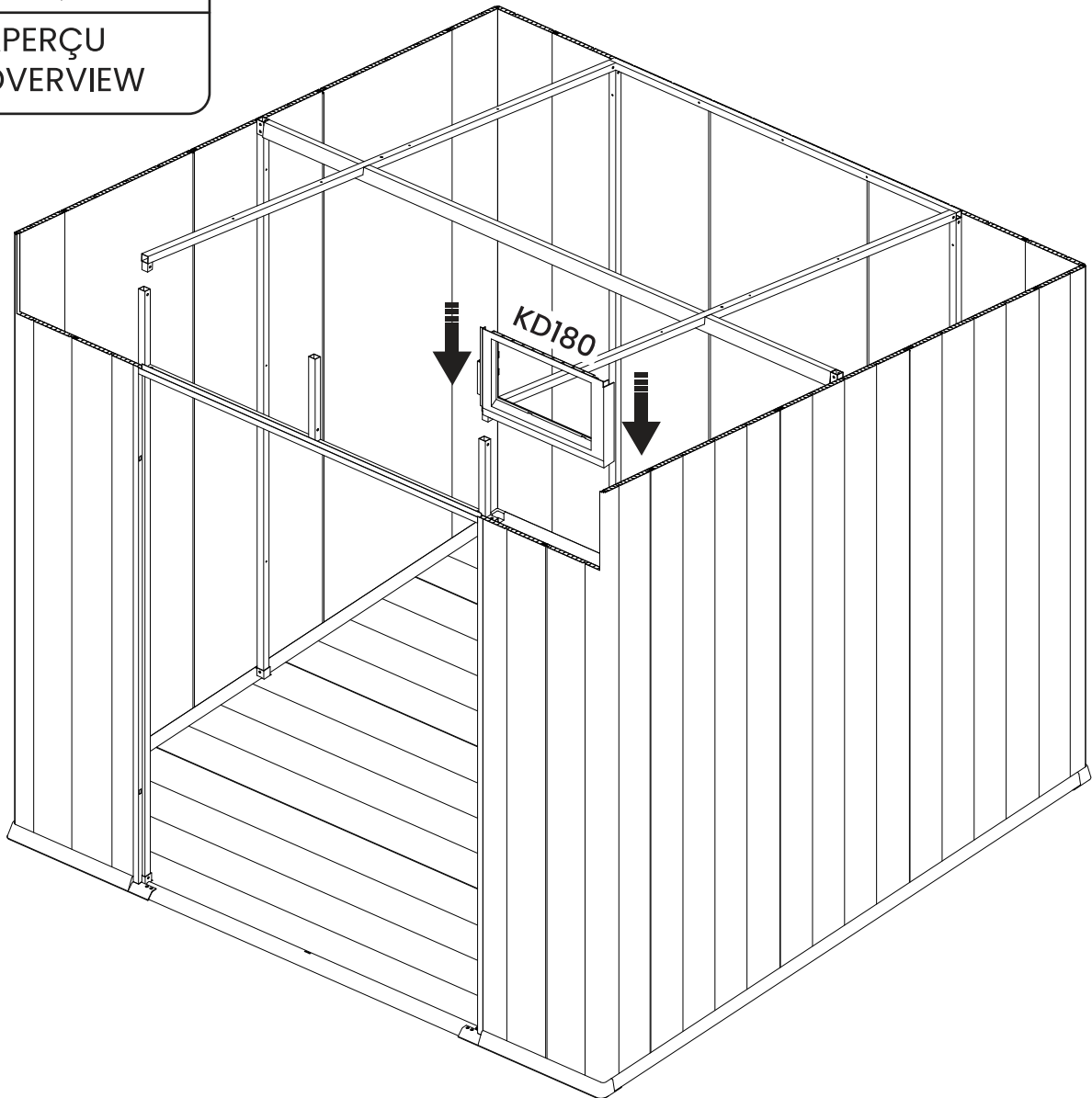

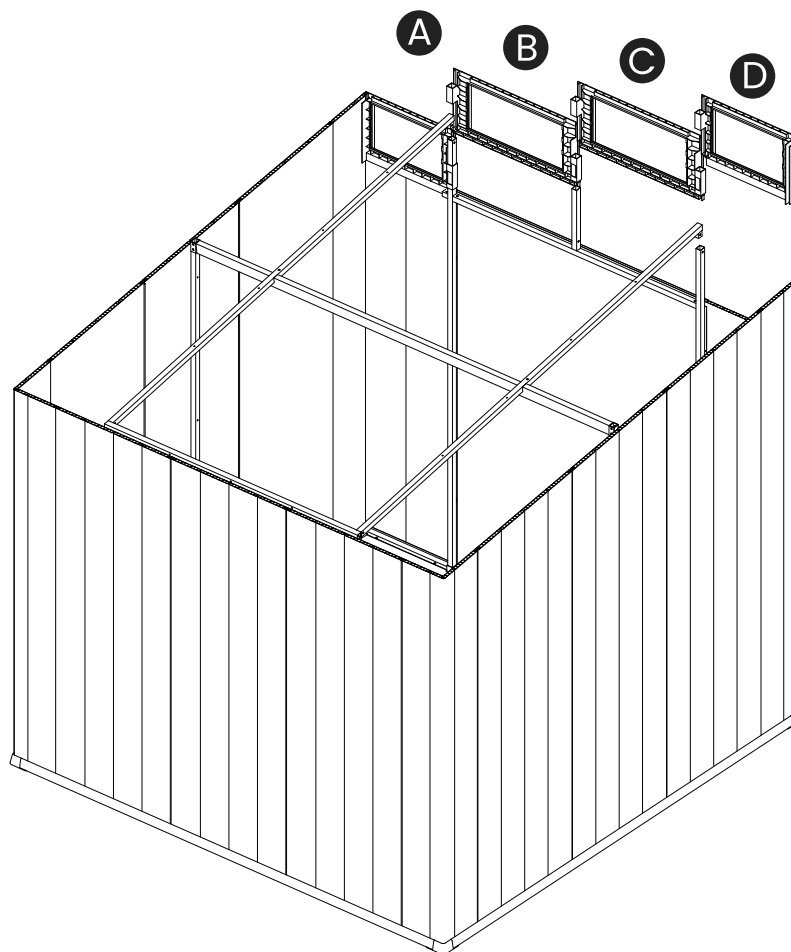
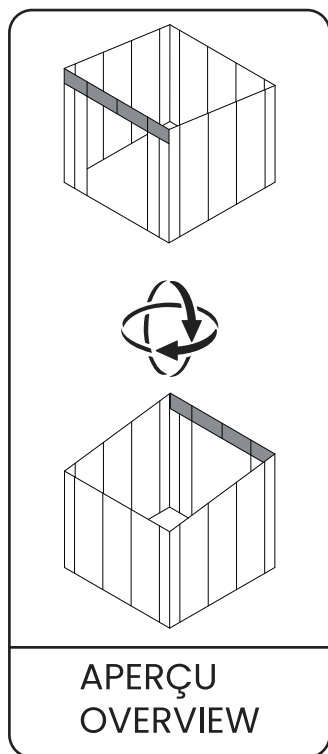



A KD180

B **C** KD181

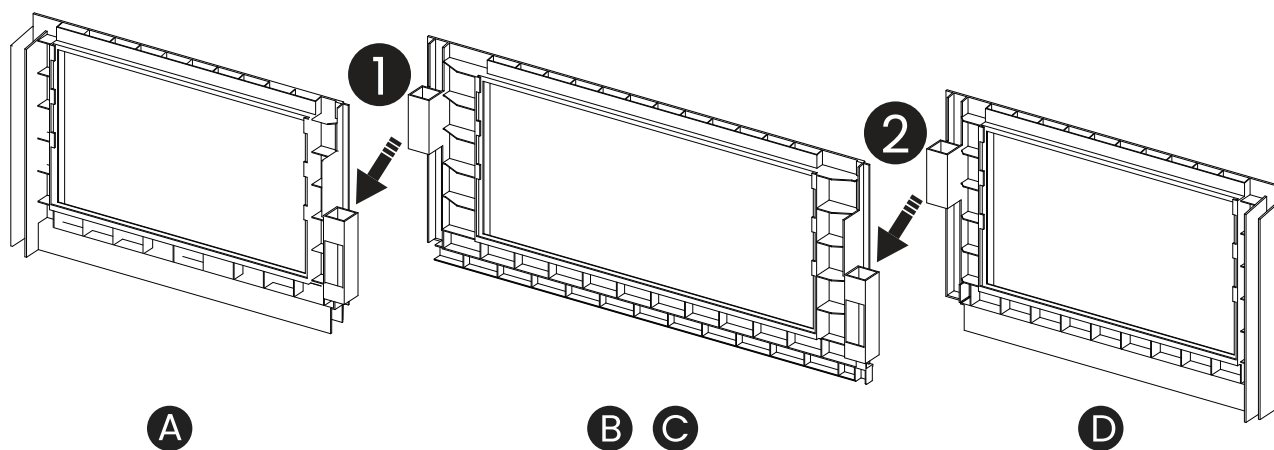
D KD179

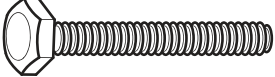

LES INSTALLER DANS L'ORDRE A-D
INSTALL THEM IN SEQUENCE A-D

	KD081	x2		KD082	x2
---	-------	----	--	-------	----

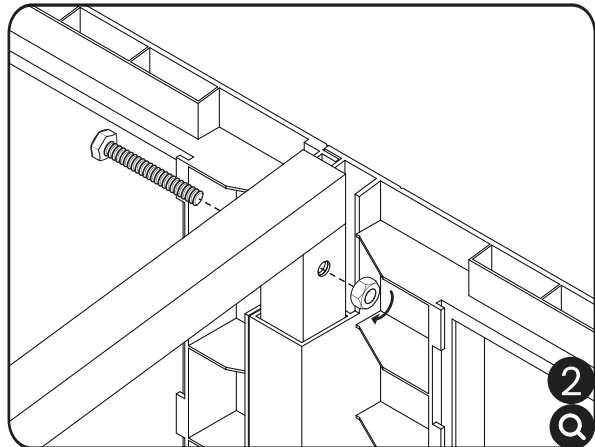
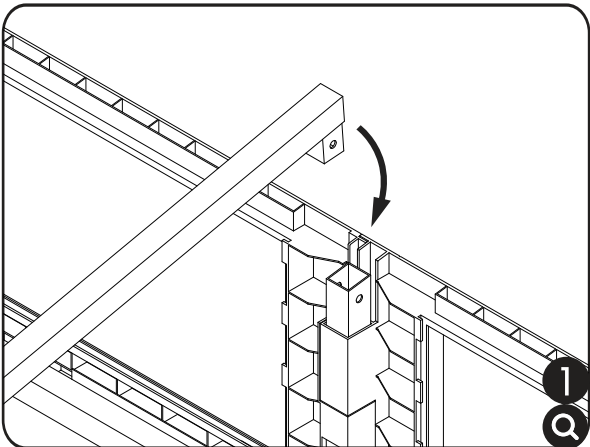
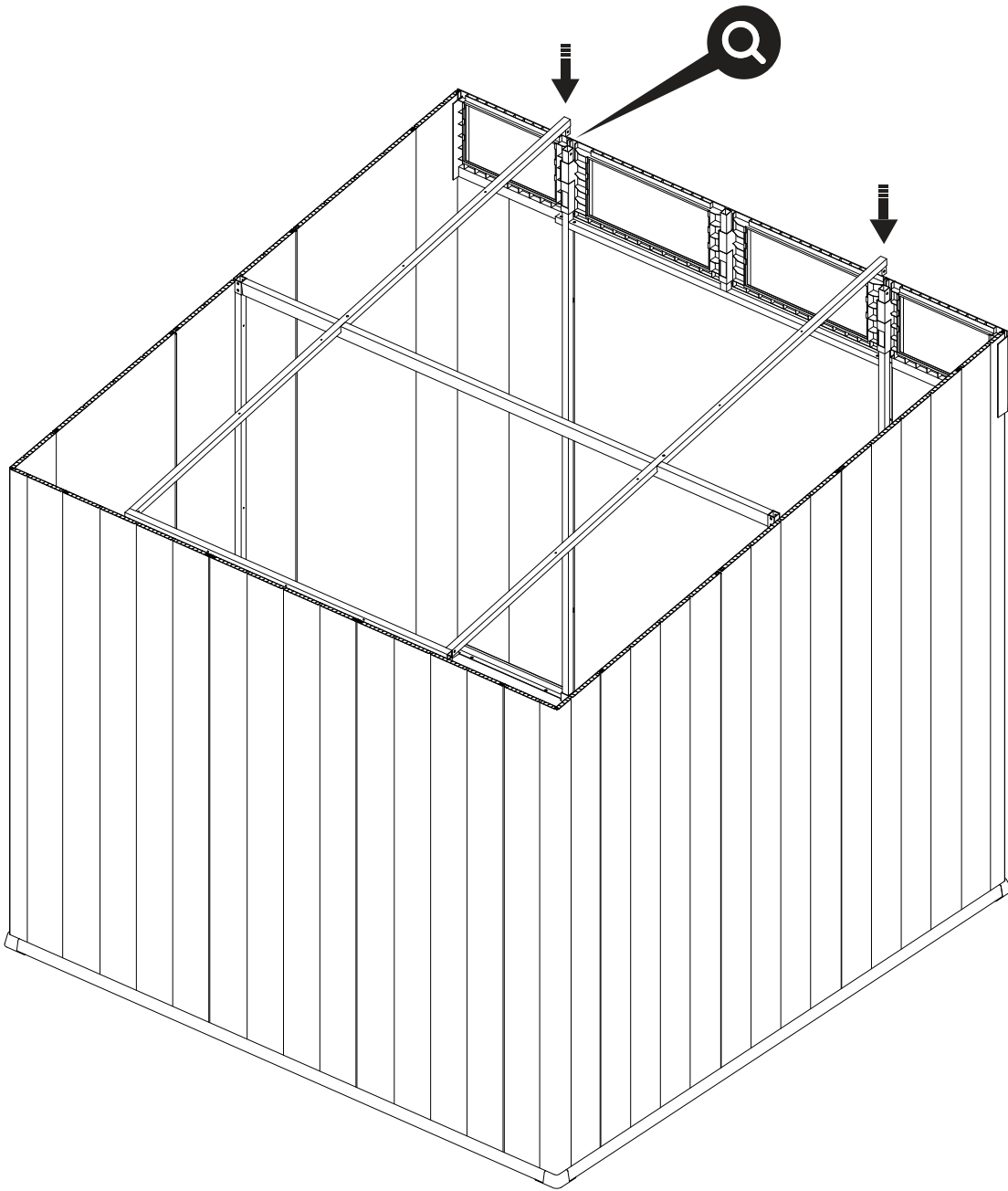

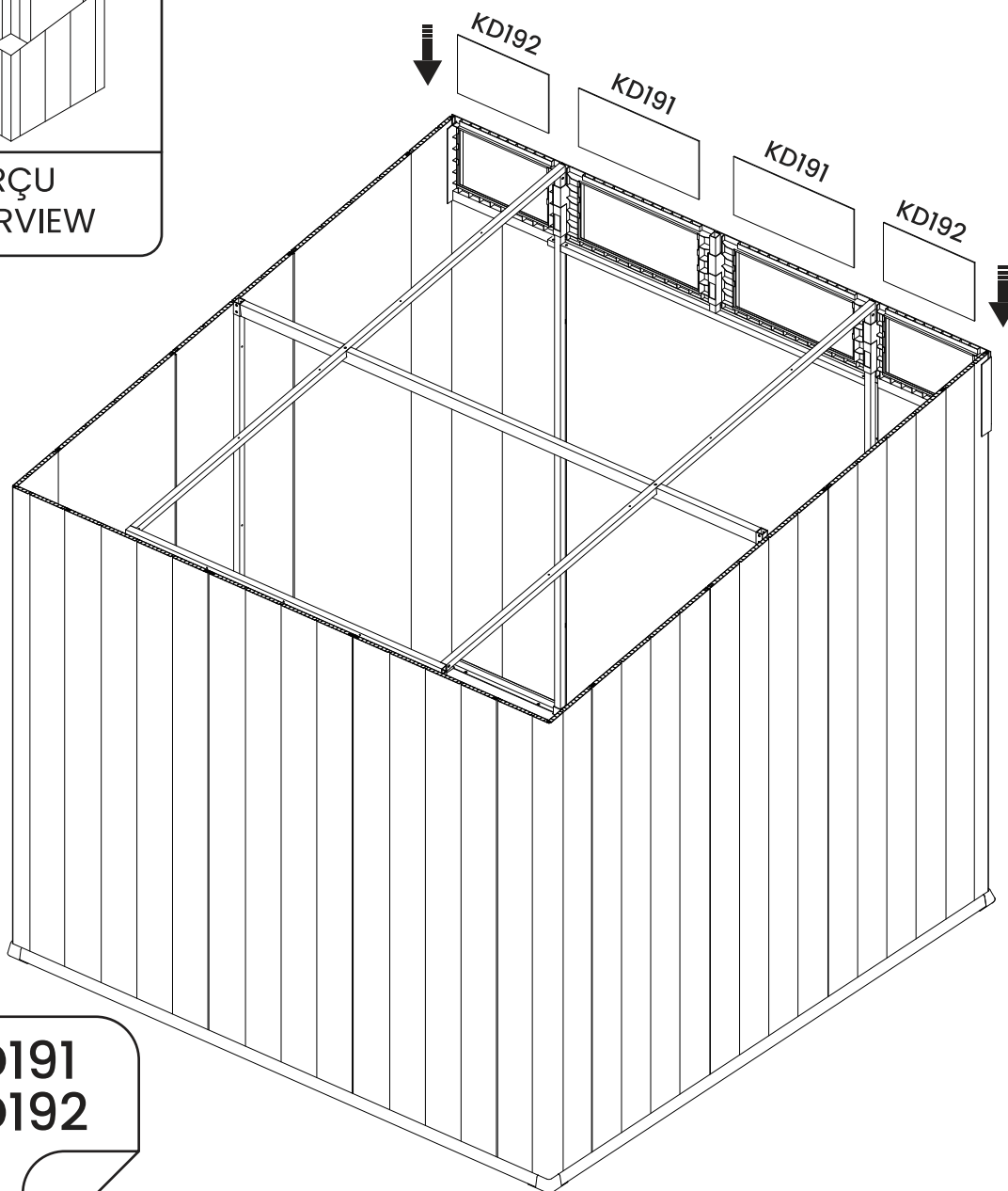
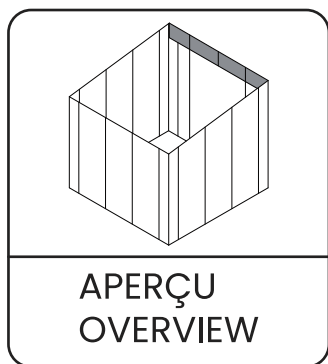

KD191
KD192

Décoller le film avant l'installation
Peel Off The Film Before Installation

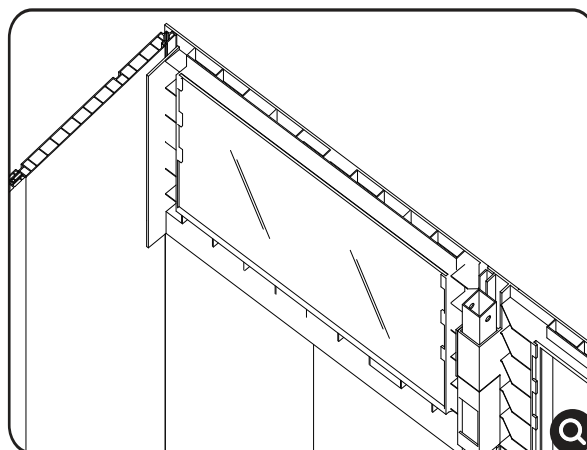
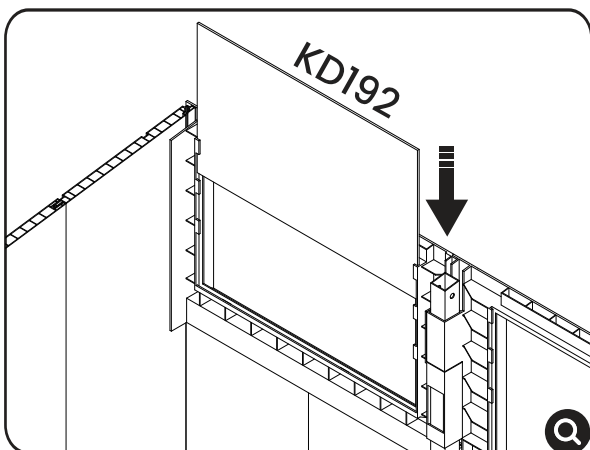

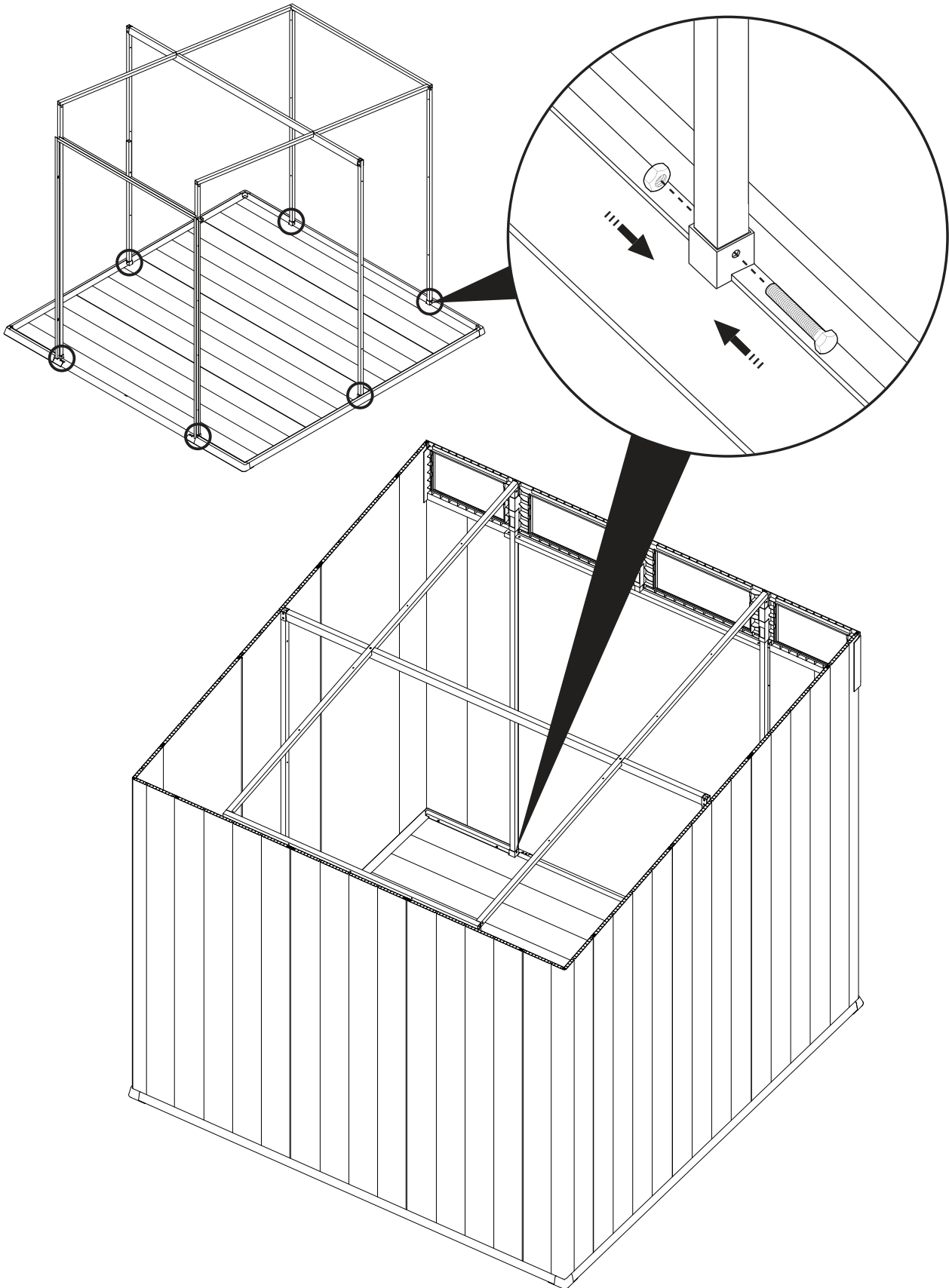
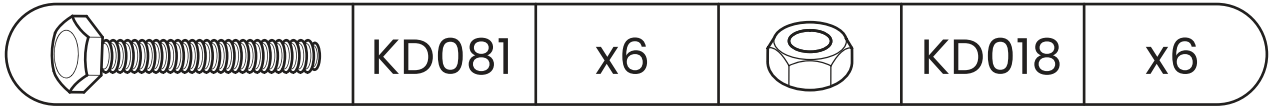

Visser le tout fermement après avoir posé le cadre.
Screw all of it tightly after laying down the frame.

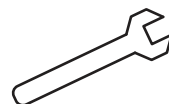

Assemblage du toit

Roof Assembly

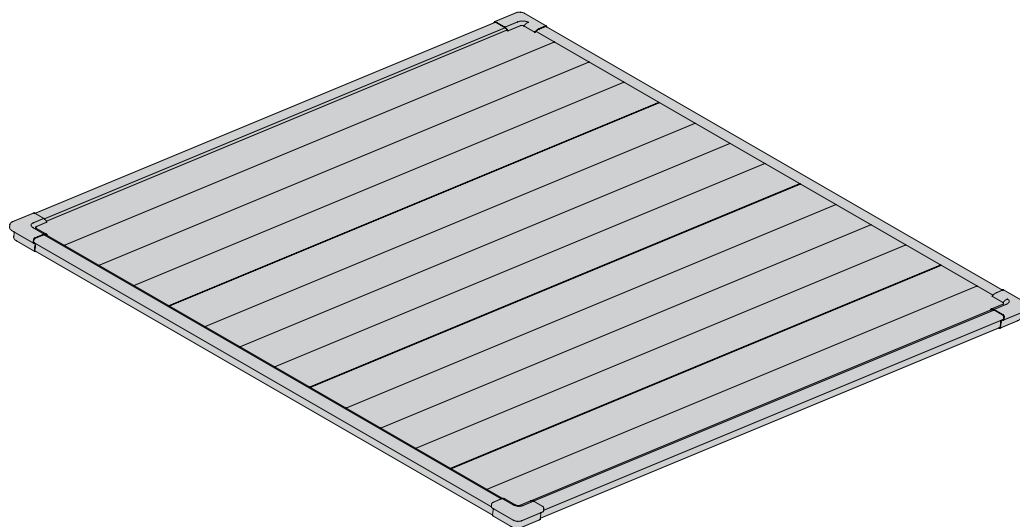

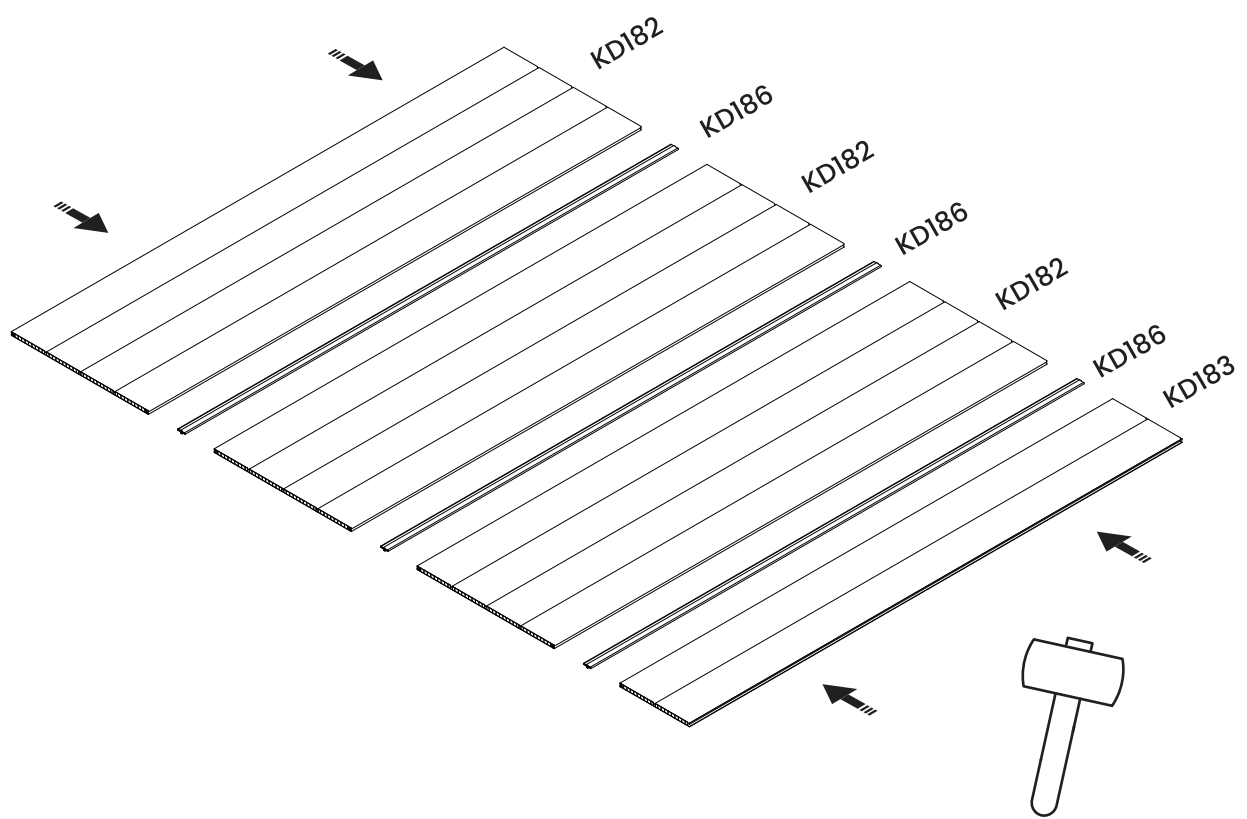
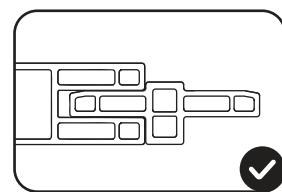
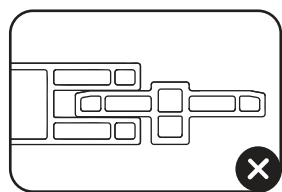
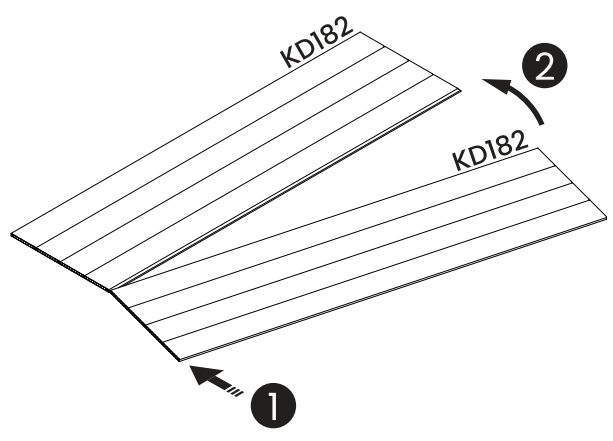
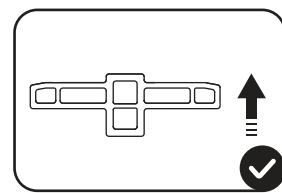
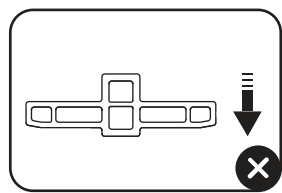
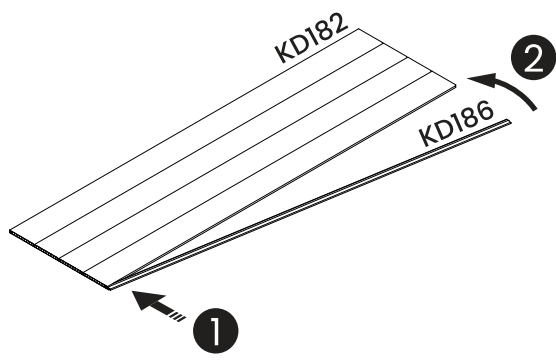

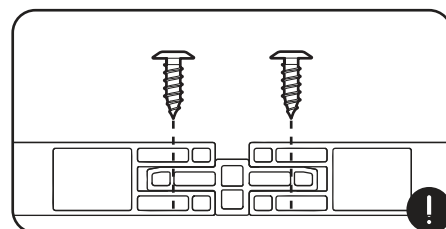
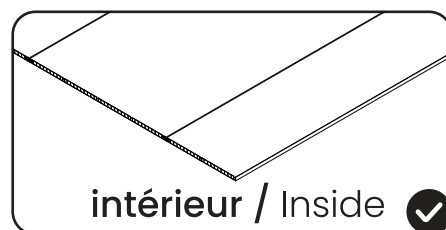
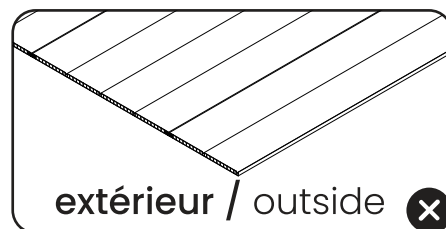
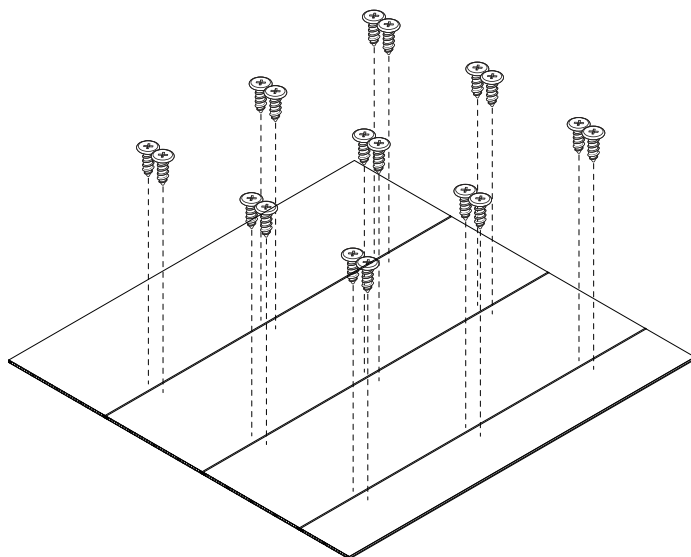
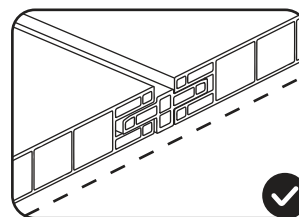
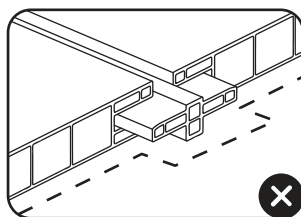
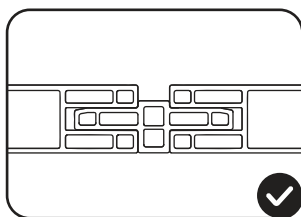
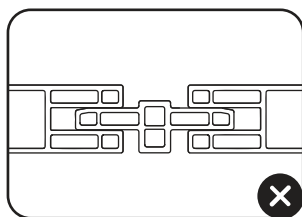
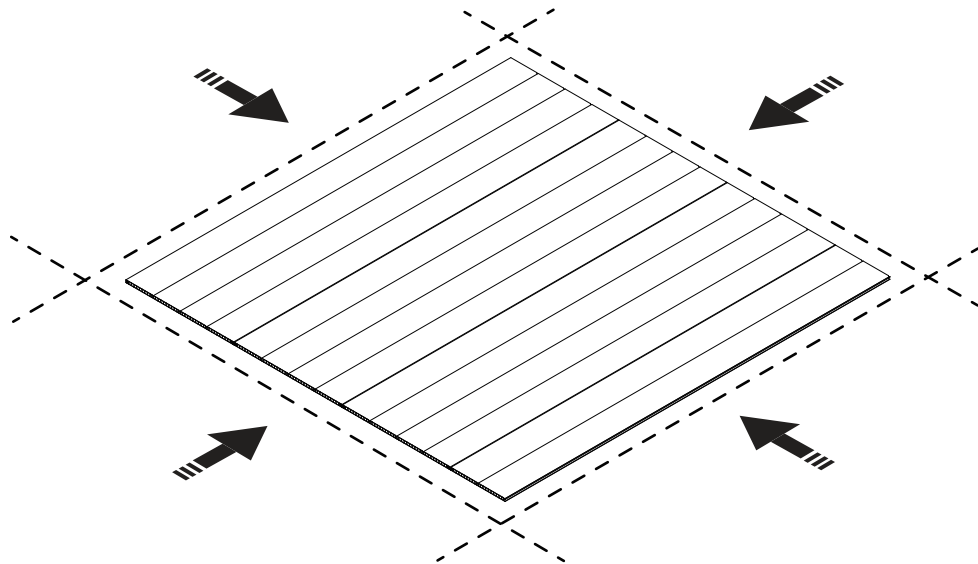

Veuillez bloquer la vis sur le côté intérieur.
Please lock the screw on the inner side.

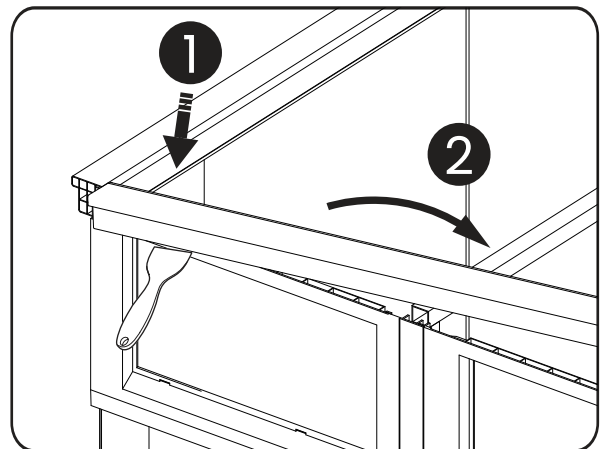
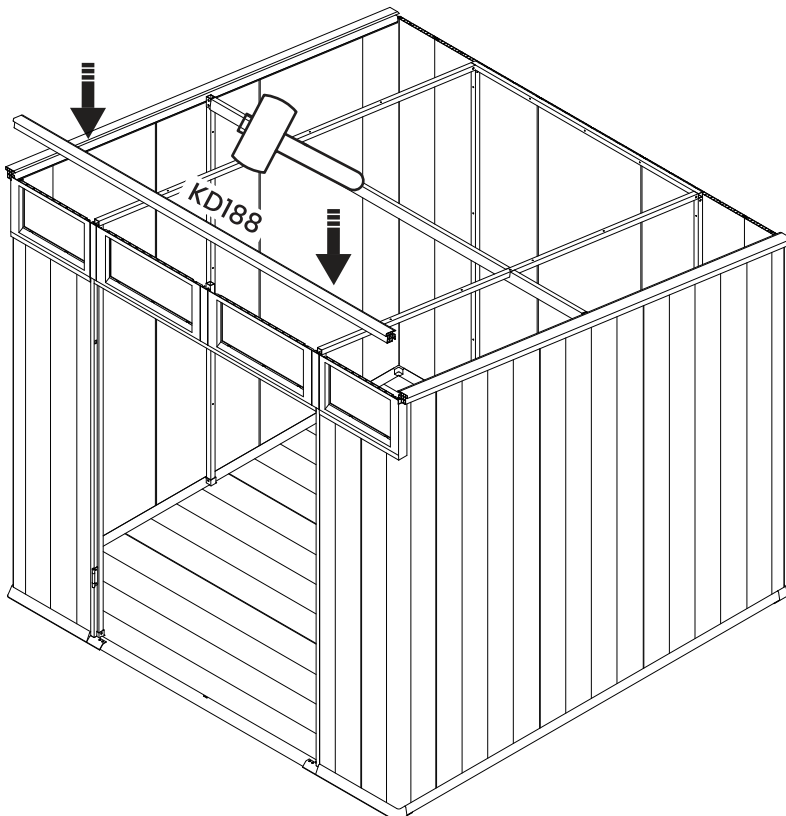
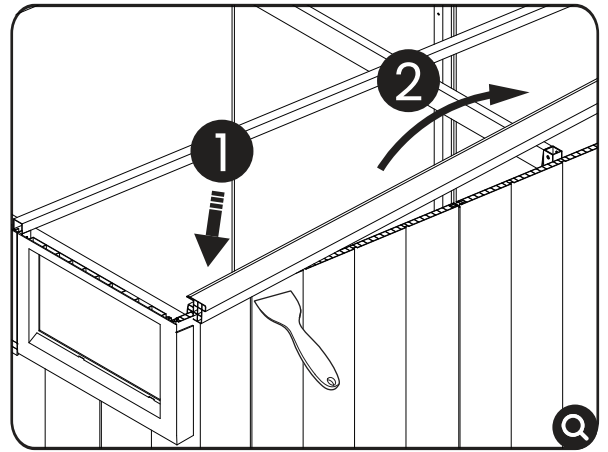
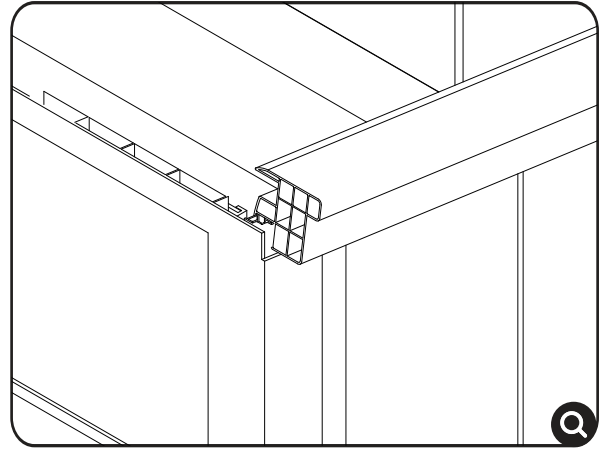
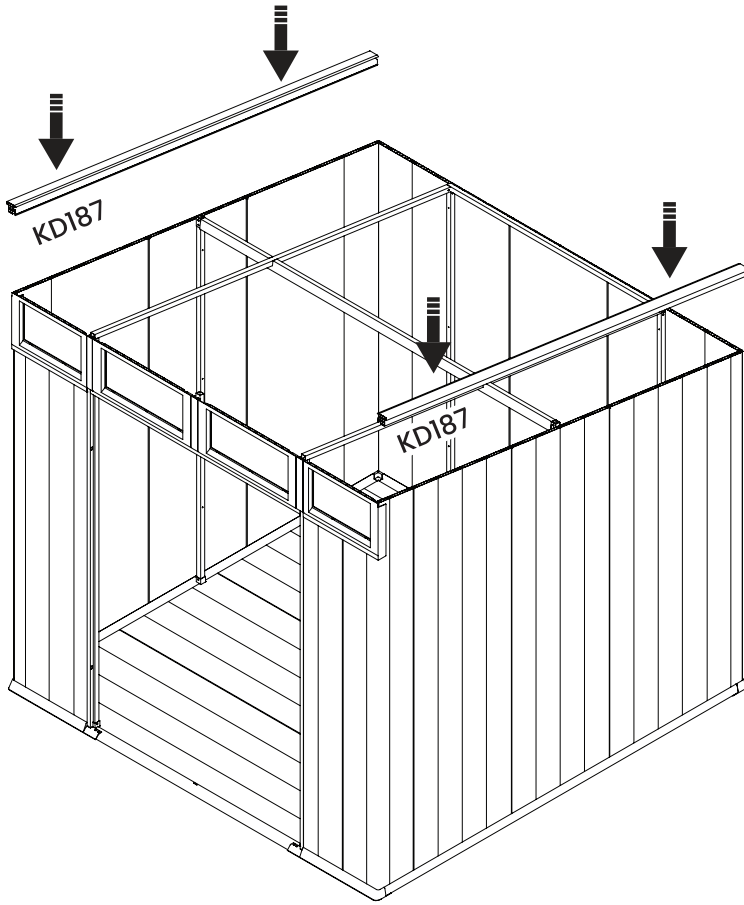



KD084

x16

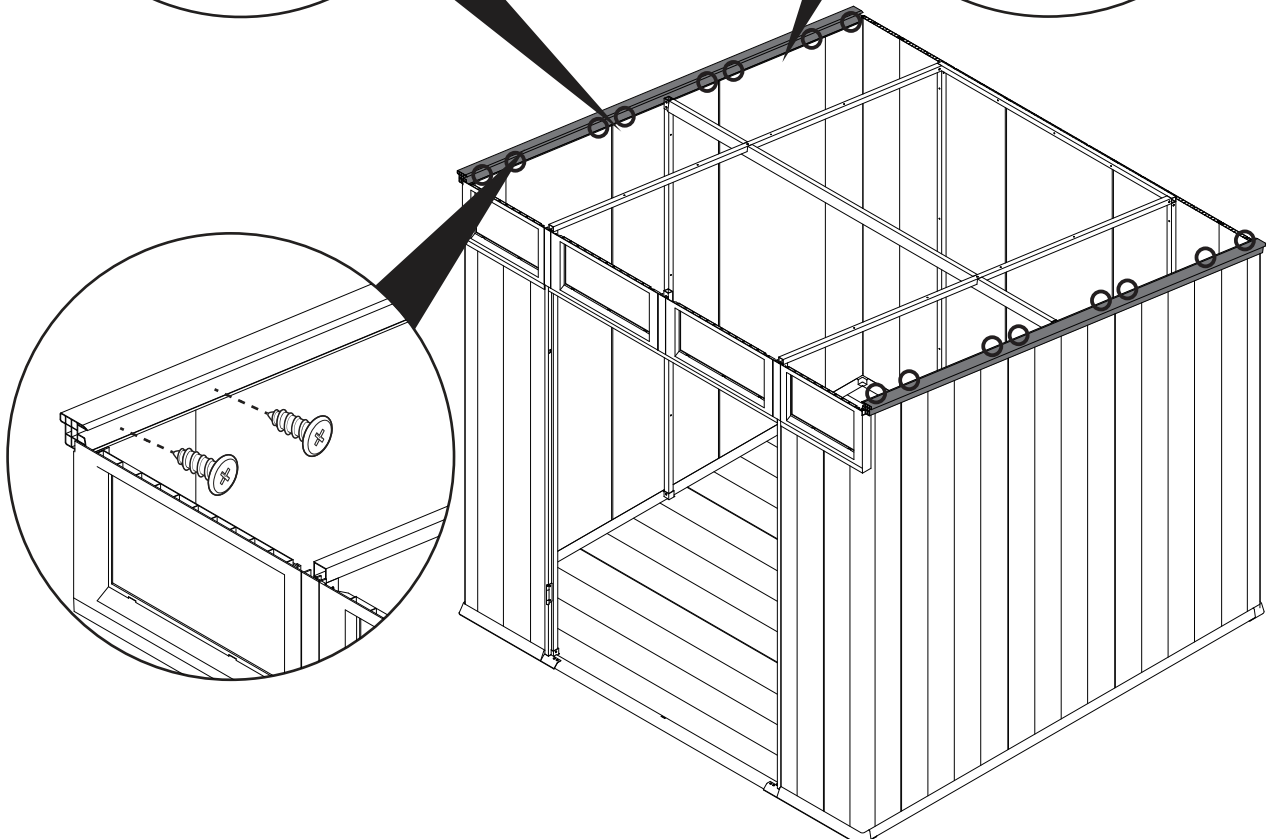
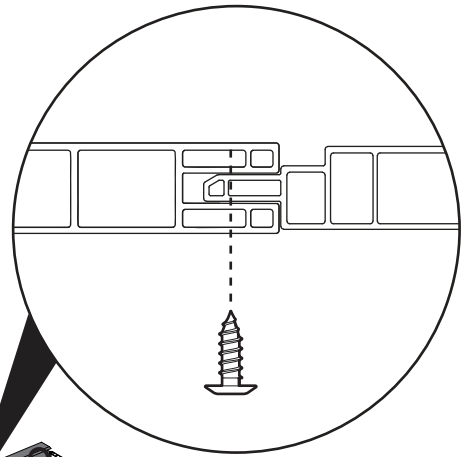
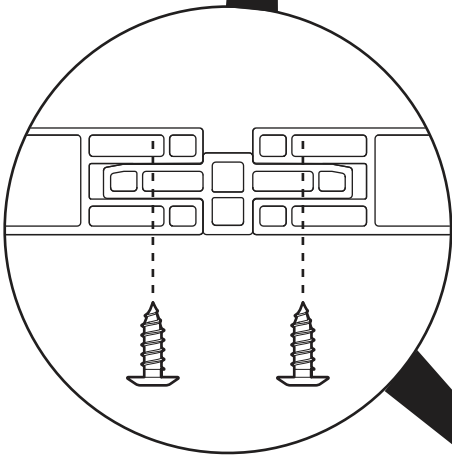
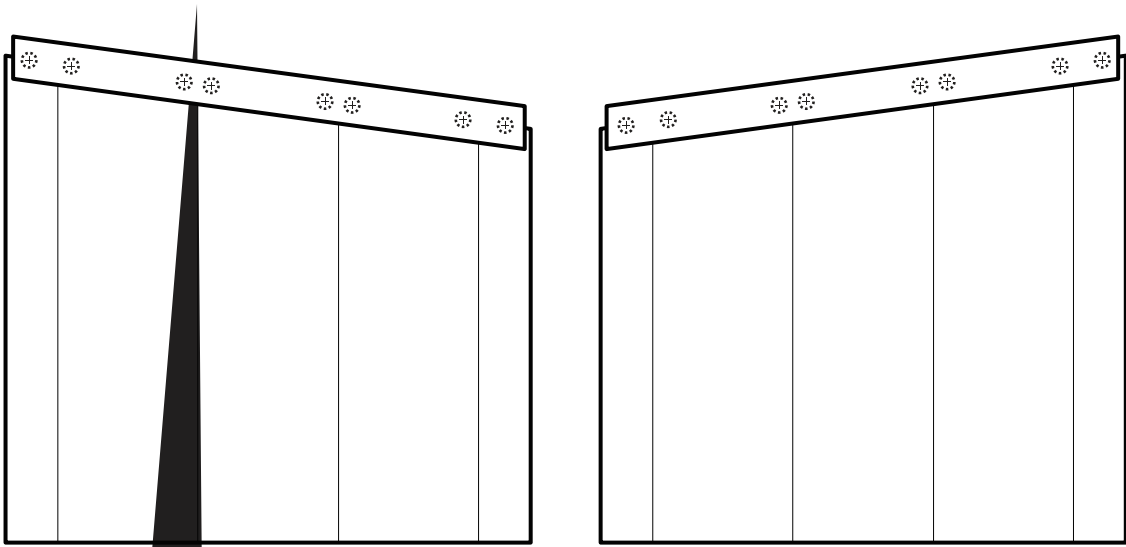

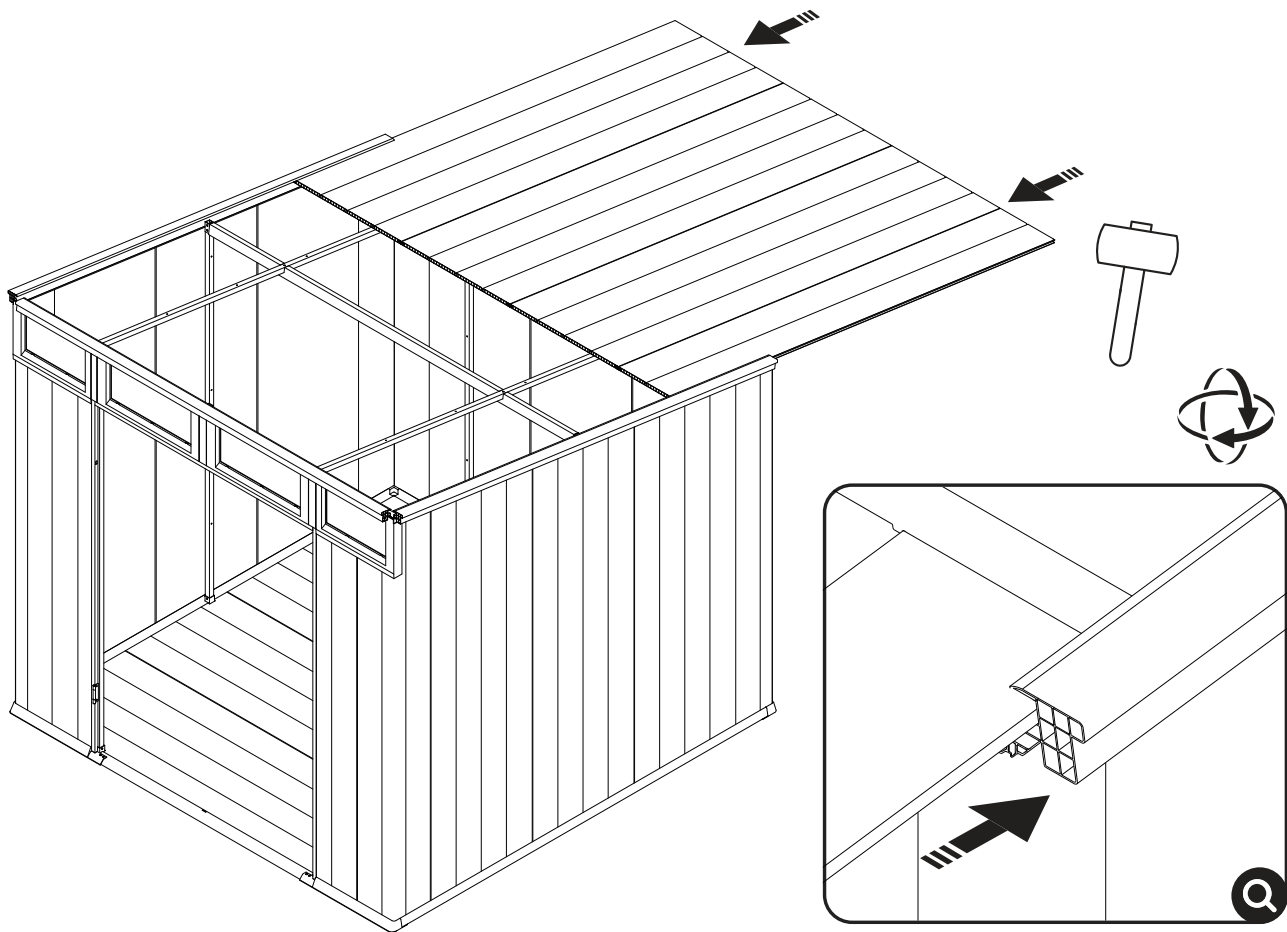

Pousser le panneau mural jusqu'au bout avant de le verrouiller.
 Push the wall panel to the end before locking.

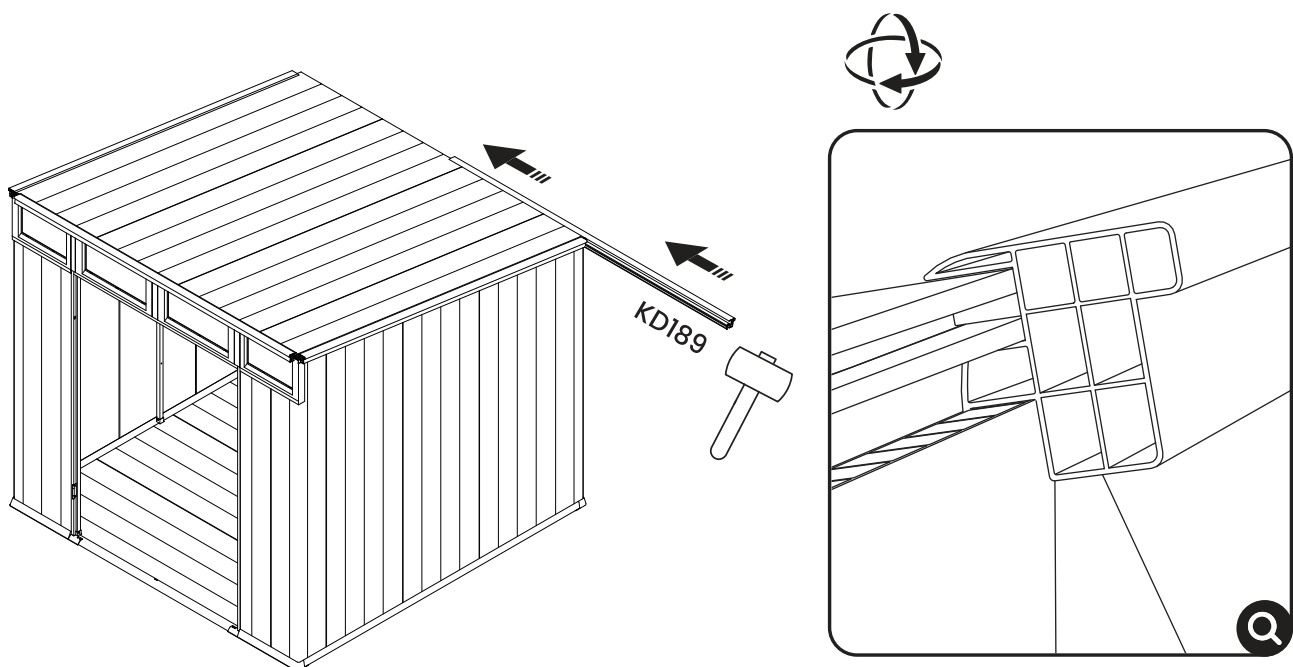

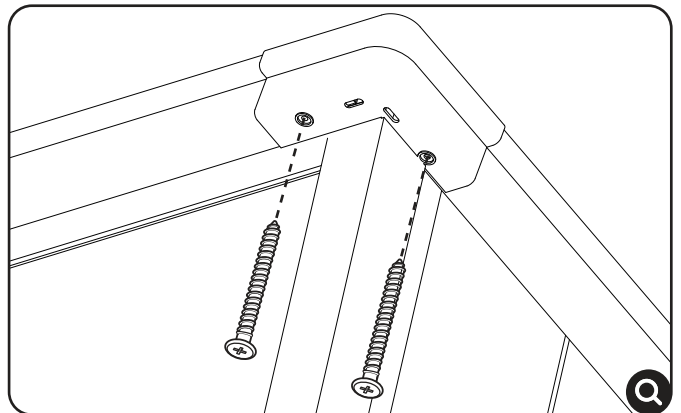
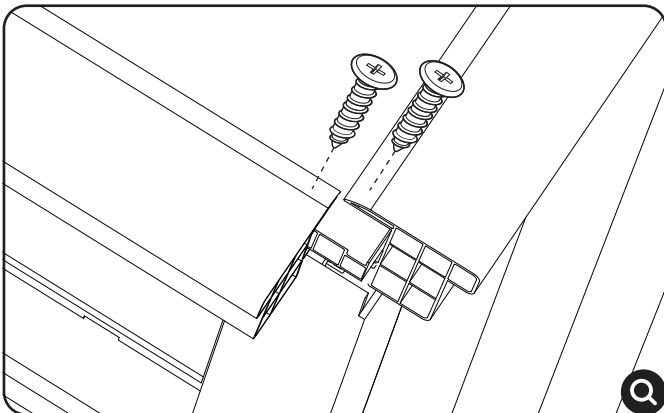
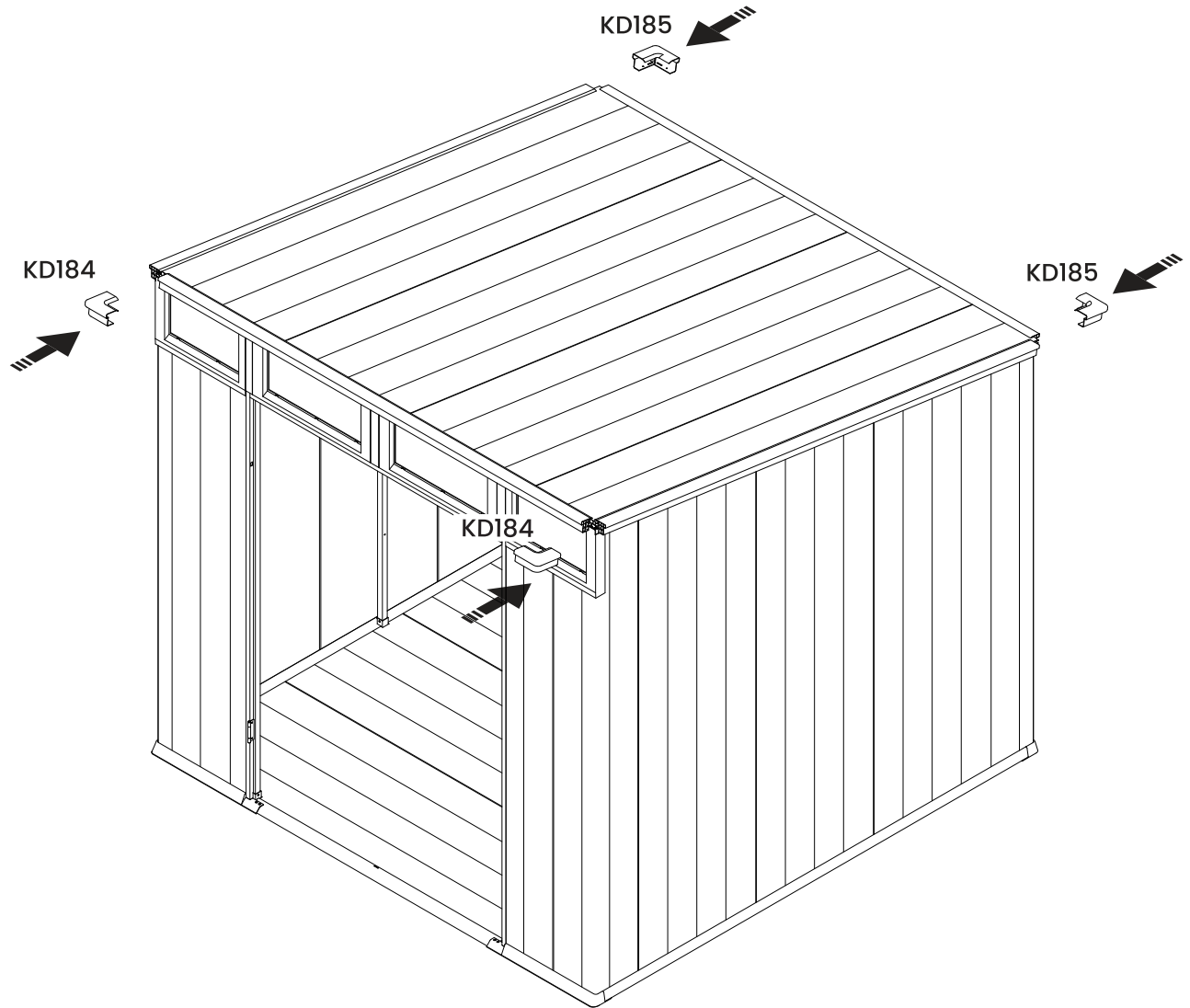



KD084

x4

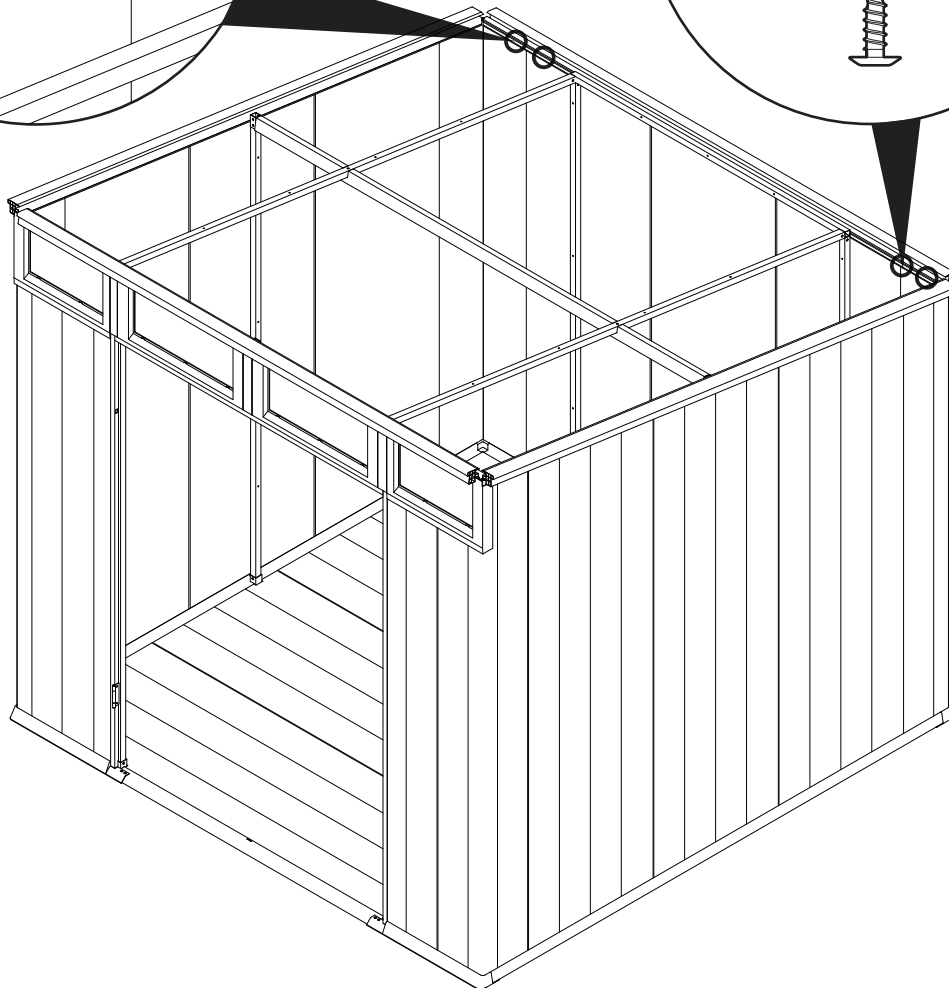
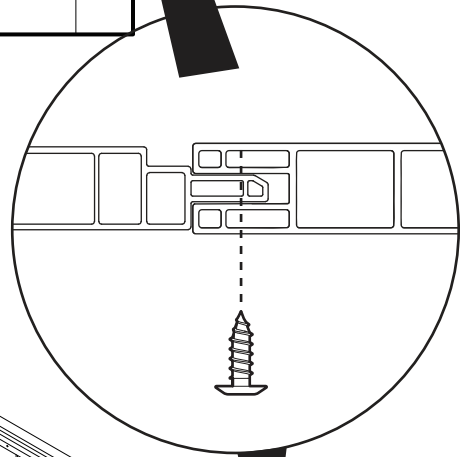
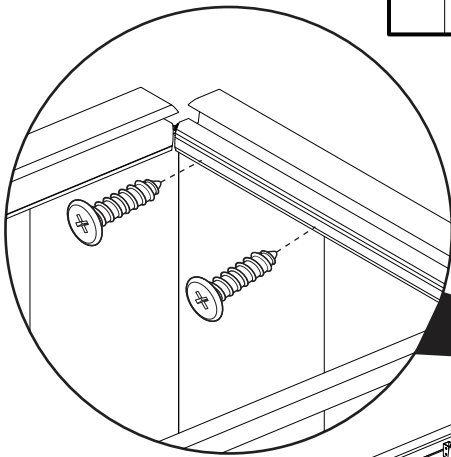
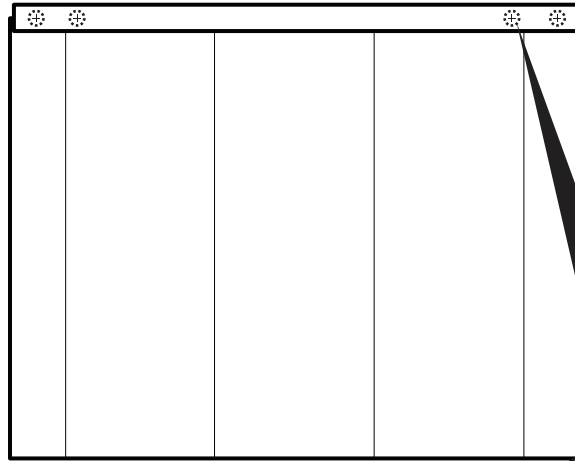

Fixation intégrale

Whole Fixation

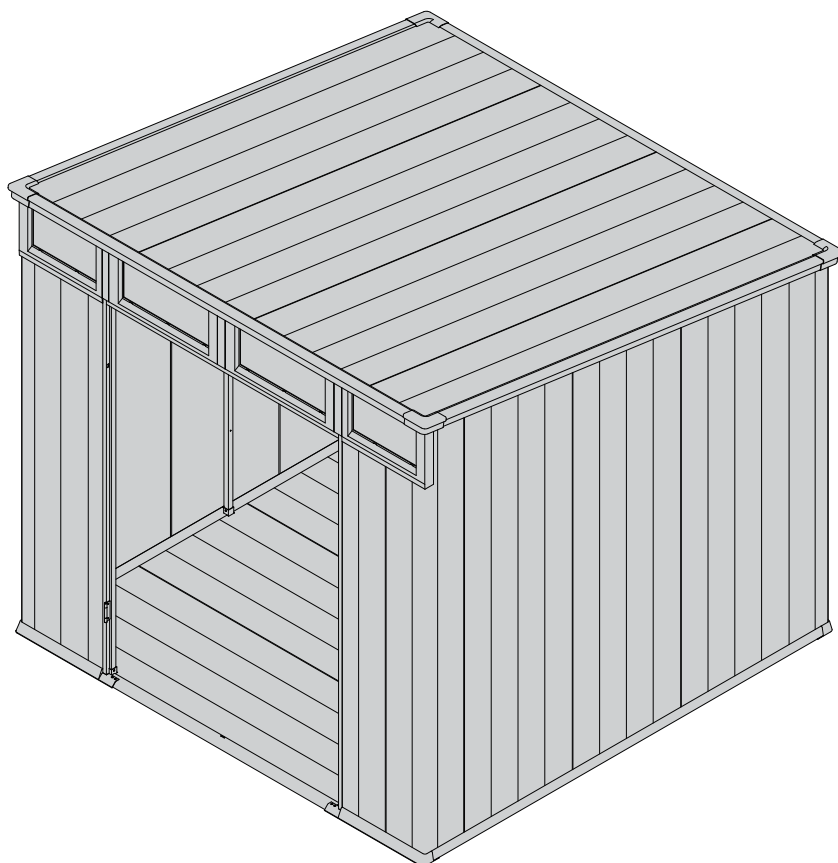

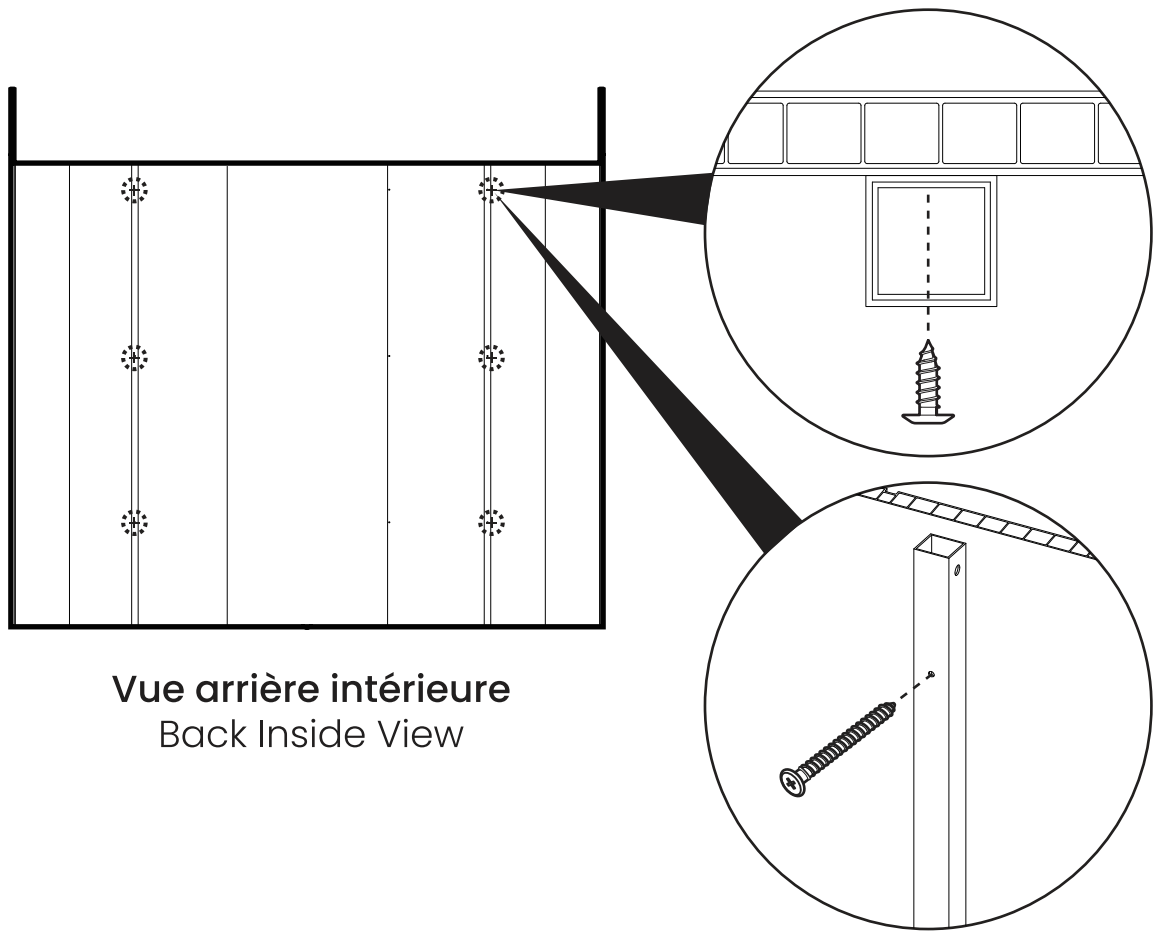

Vue arrière intérieure
Back Inside View

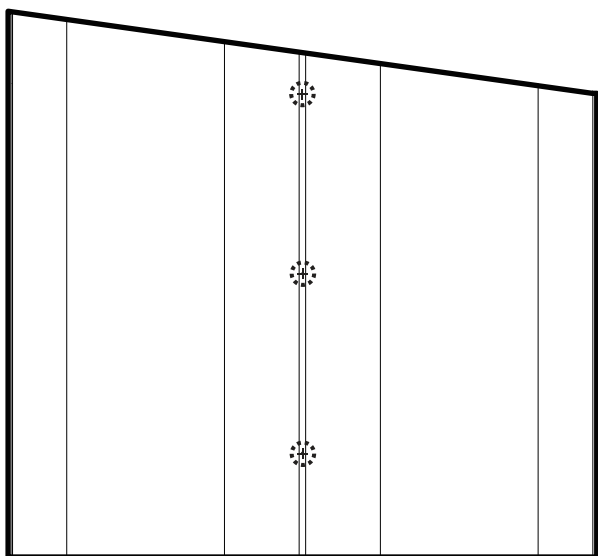

Vue intérieure gauche
Left Inside View

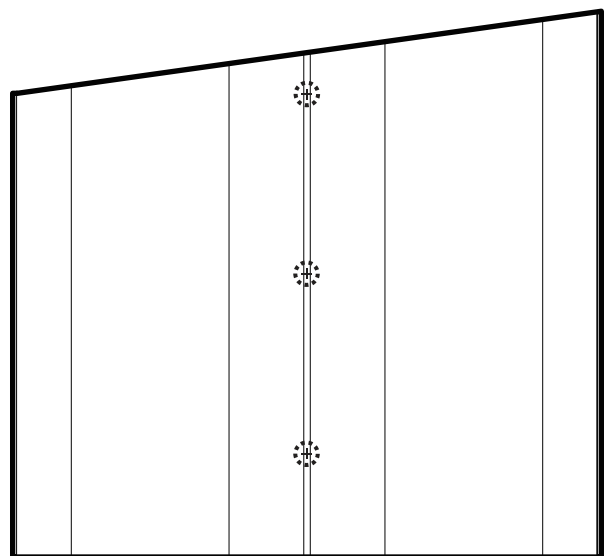

Vue intérieure droite
Left Inside View

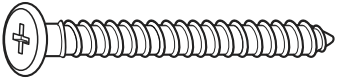

KD085

x6

Vis intérieur / Screw Inside

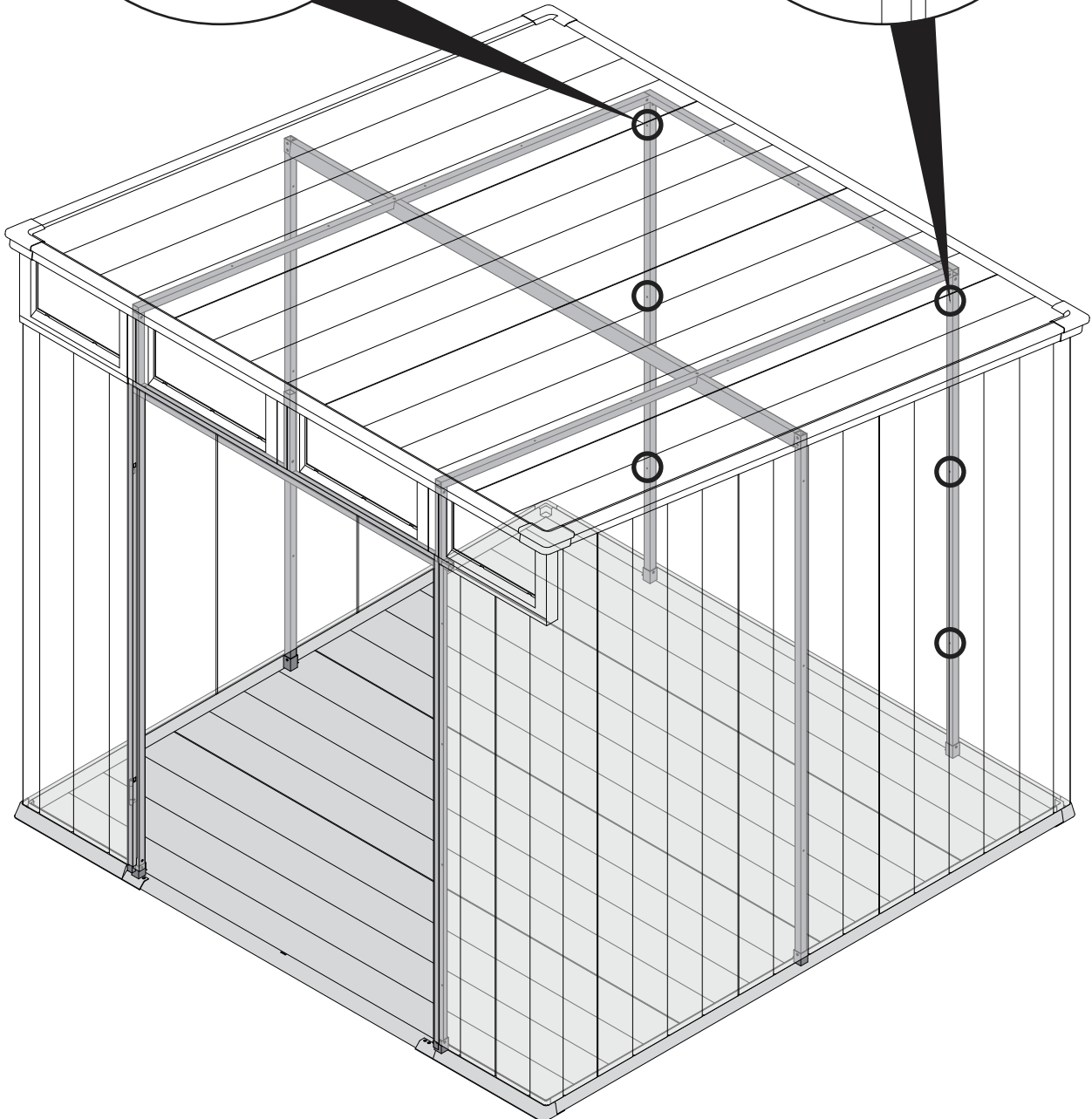
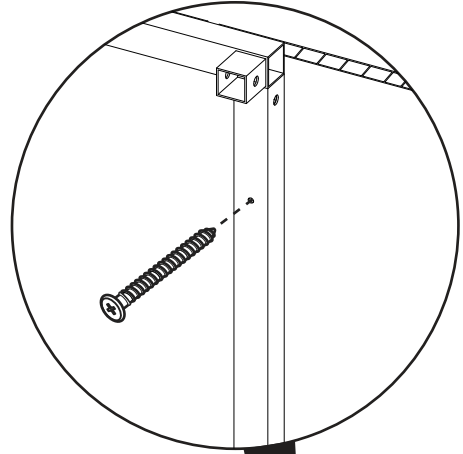
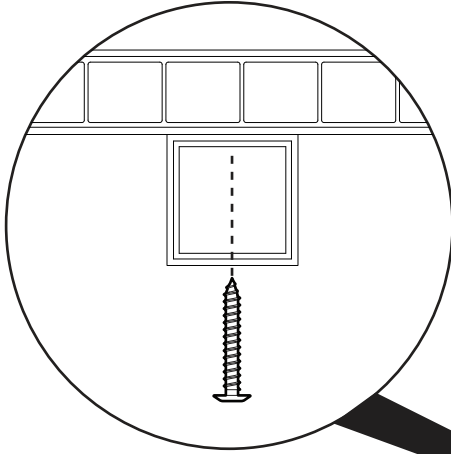



KD085

x6

Vis intérieur / Screw Inside

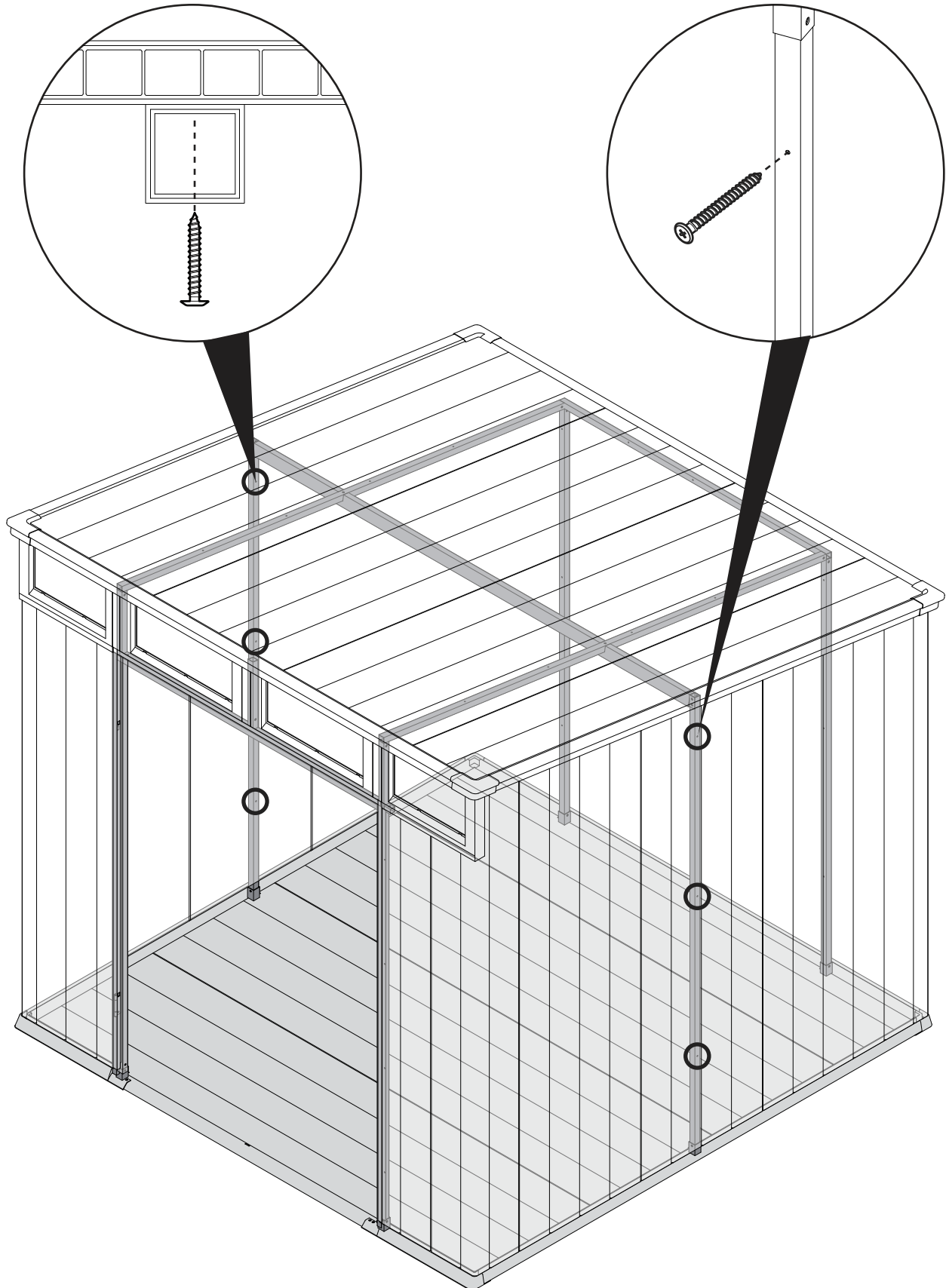

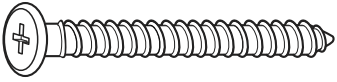

KD085

x8

Vis intérieur / Screw Inside

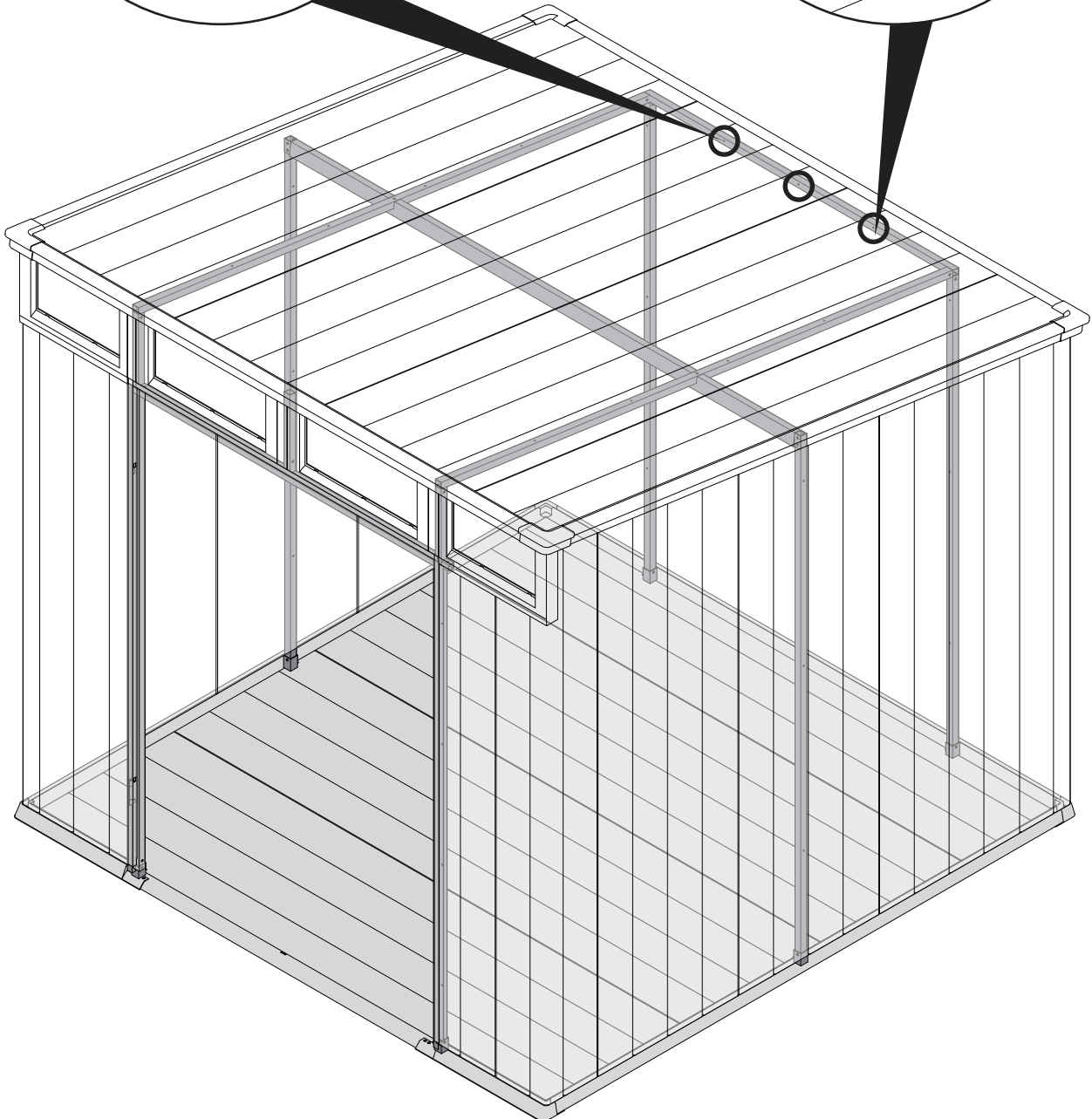
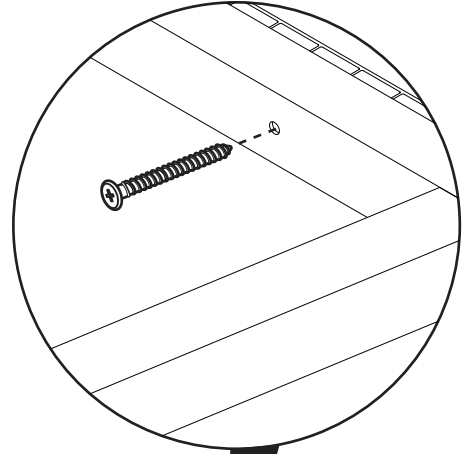
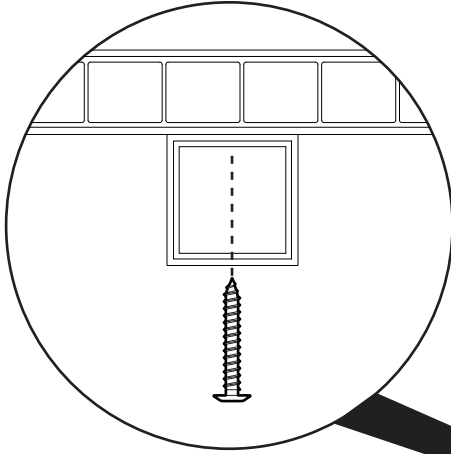

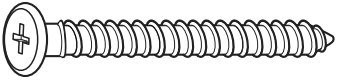

KD085

x8

Vis intérieur / Screw Inside

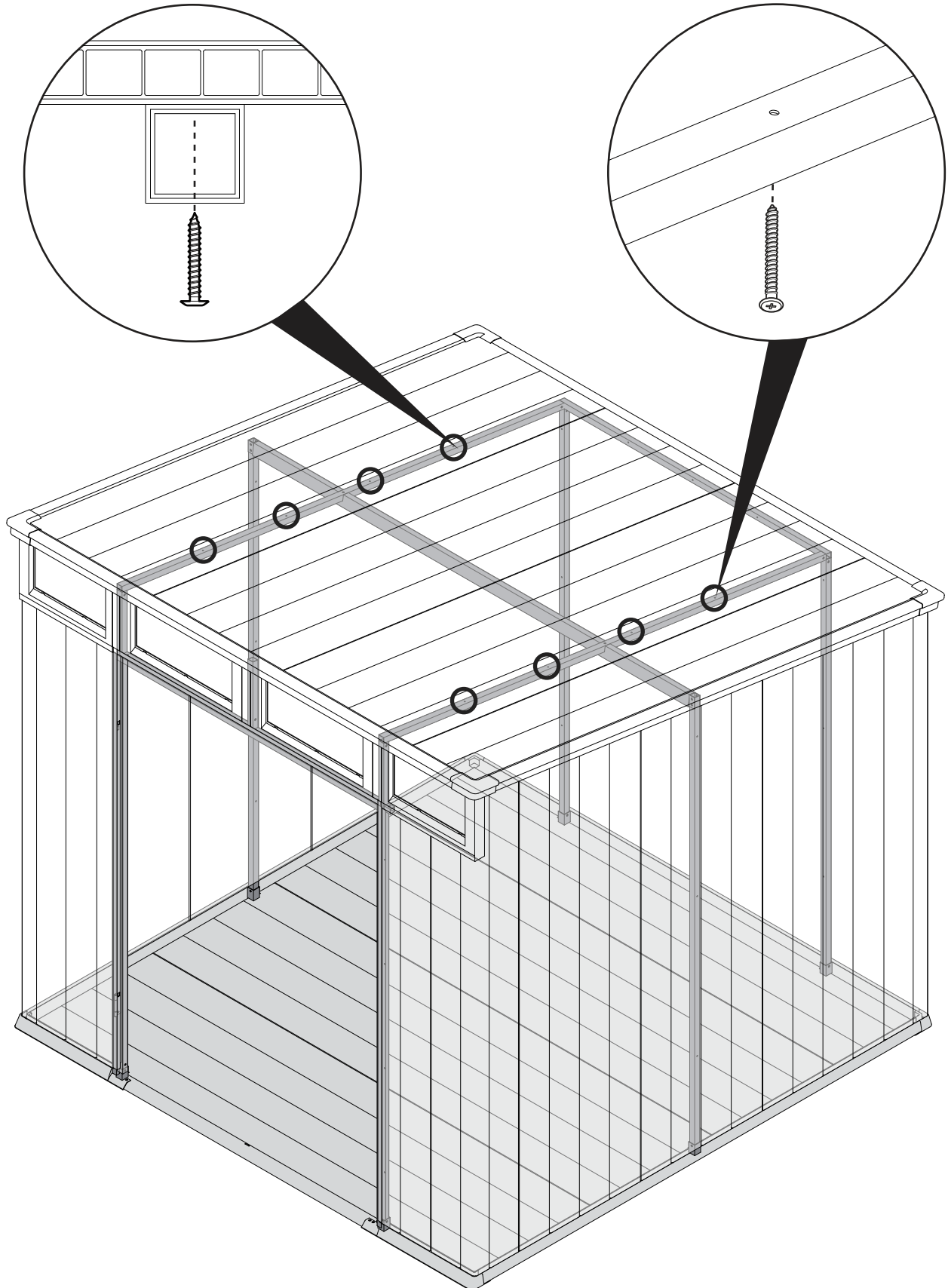

Assemblage de portes

Door Assembly

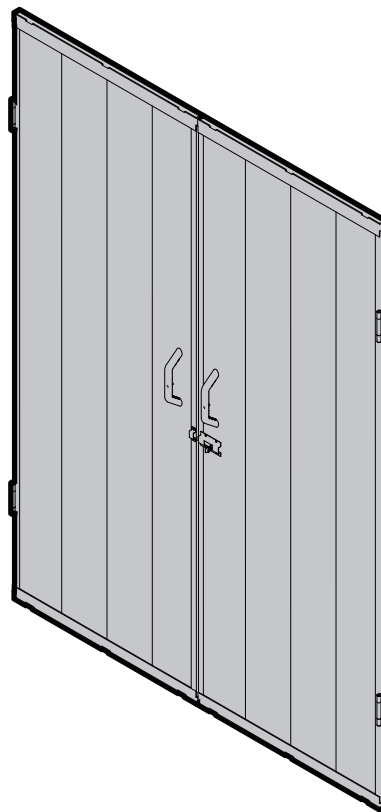

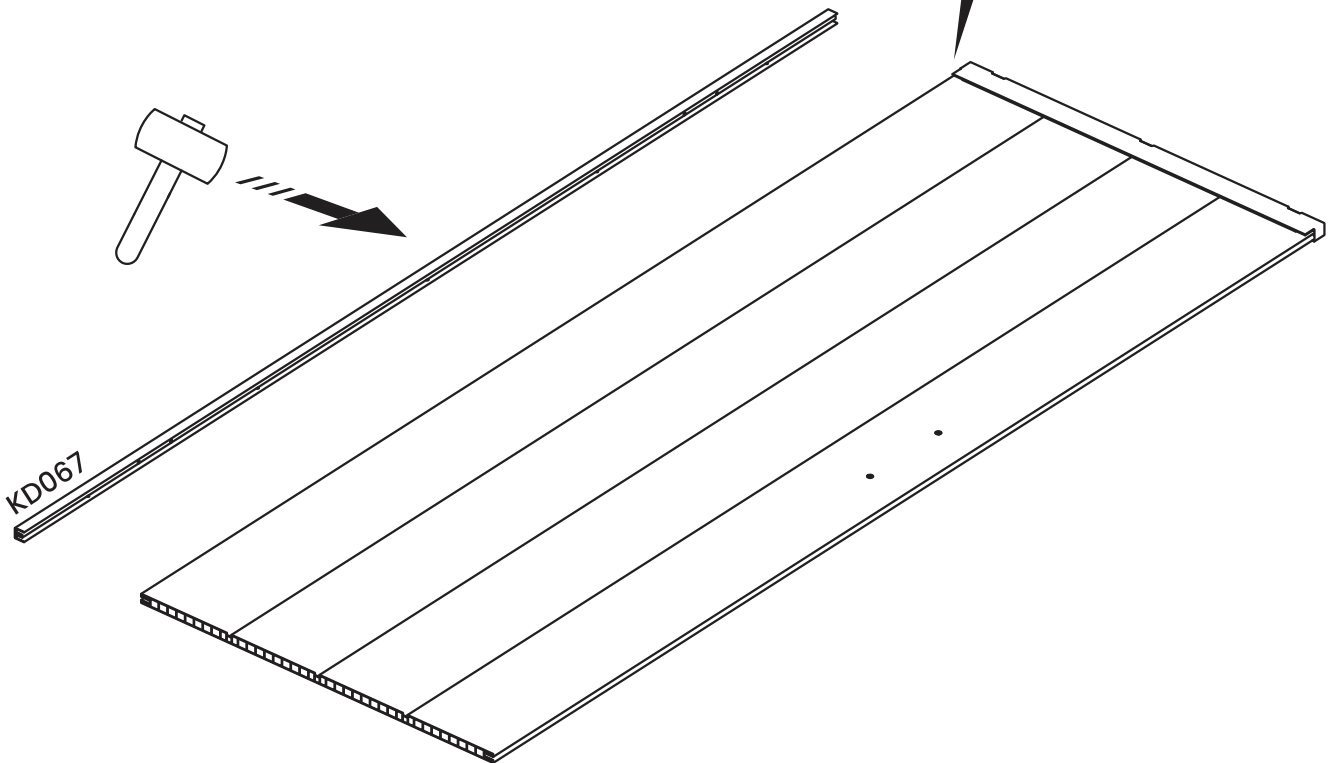
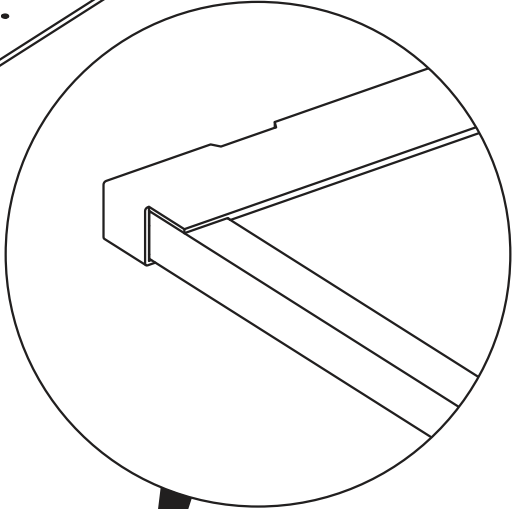
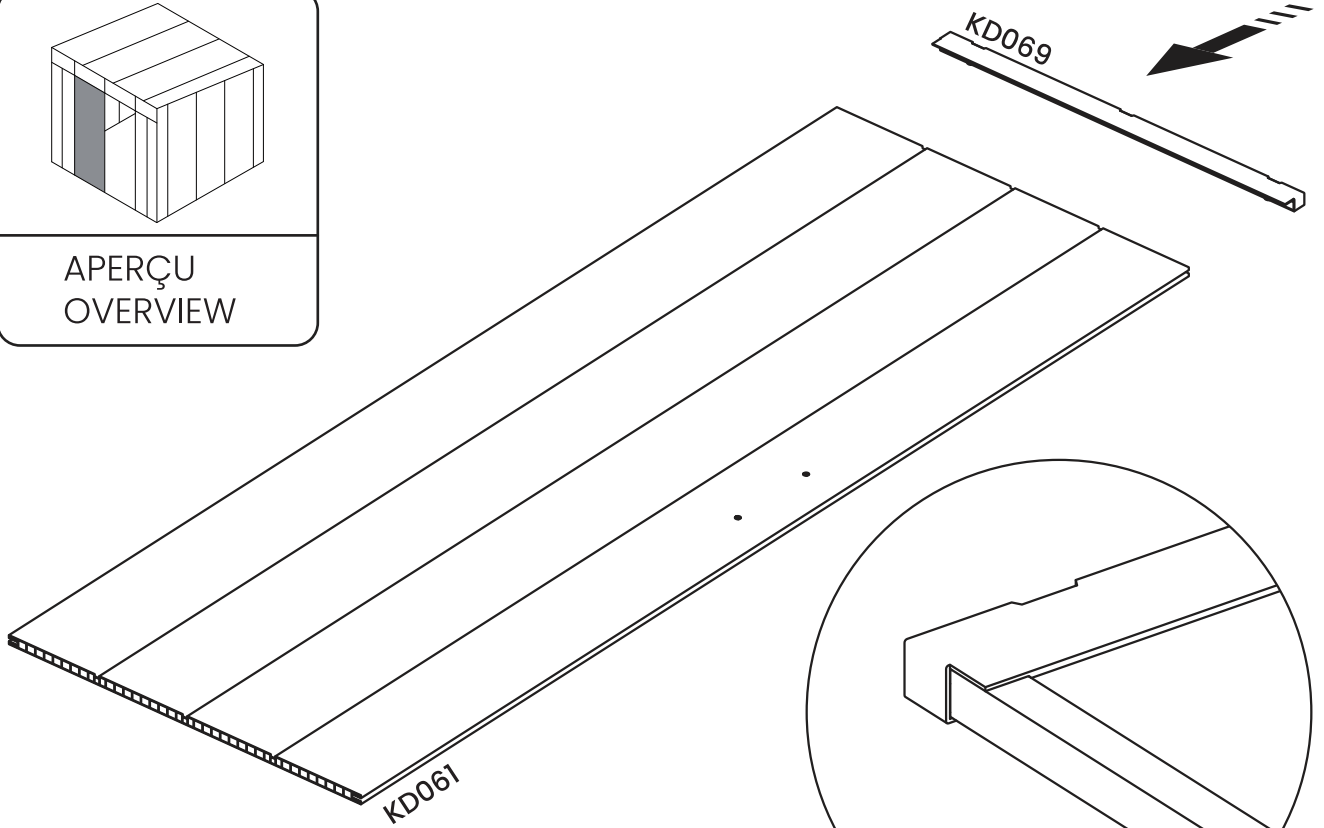
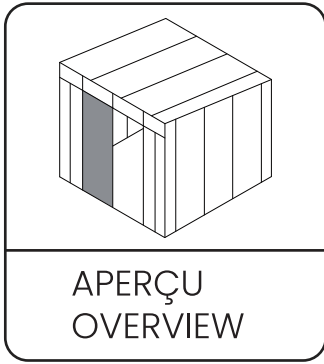

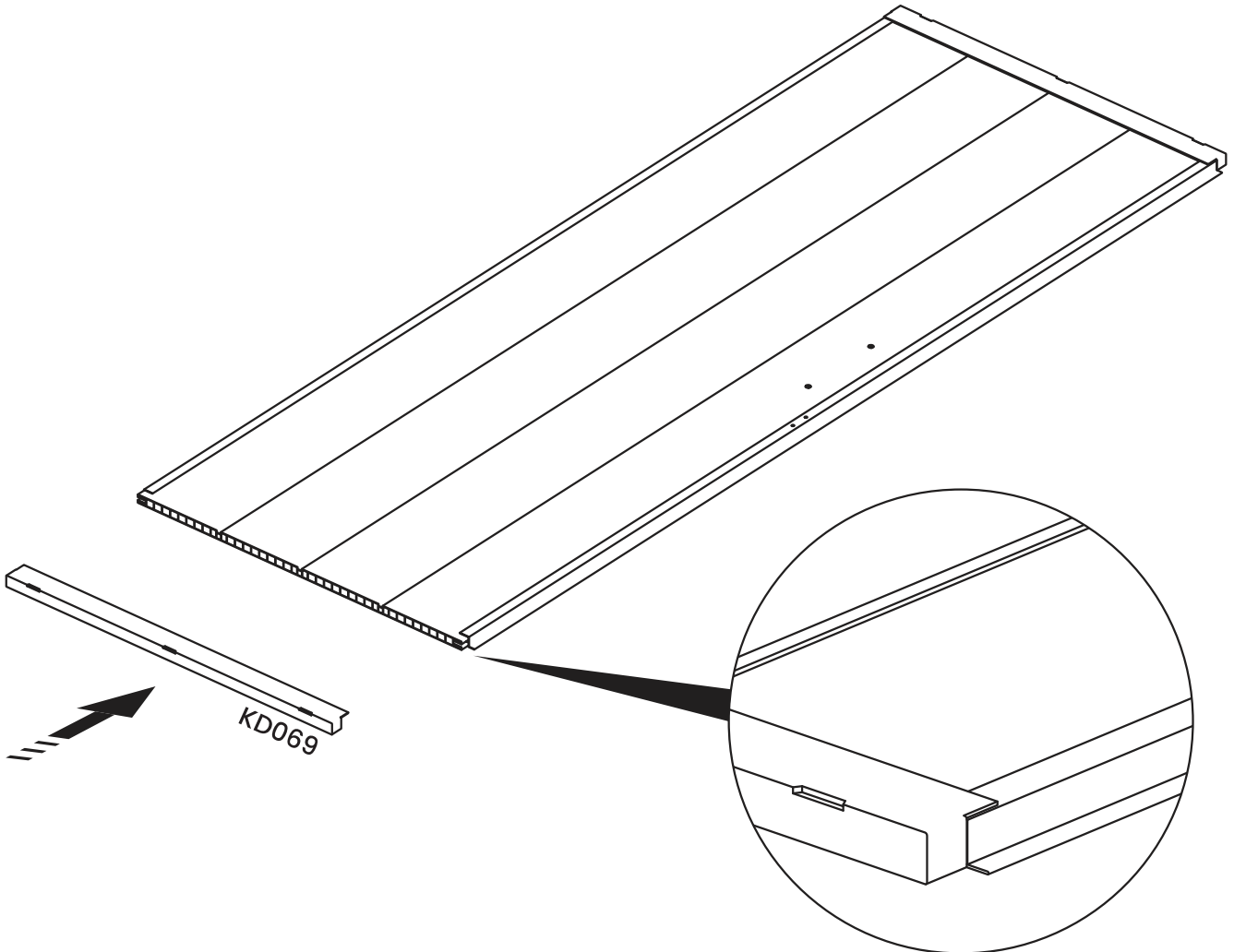
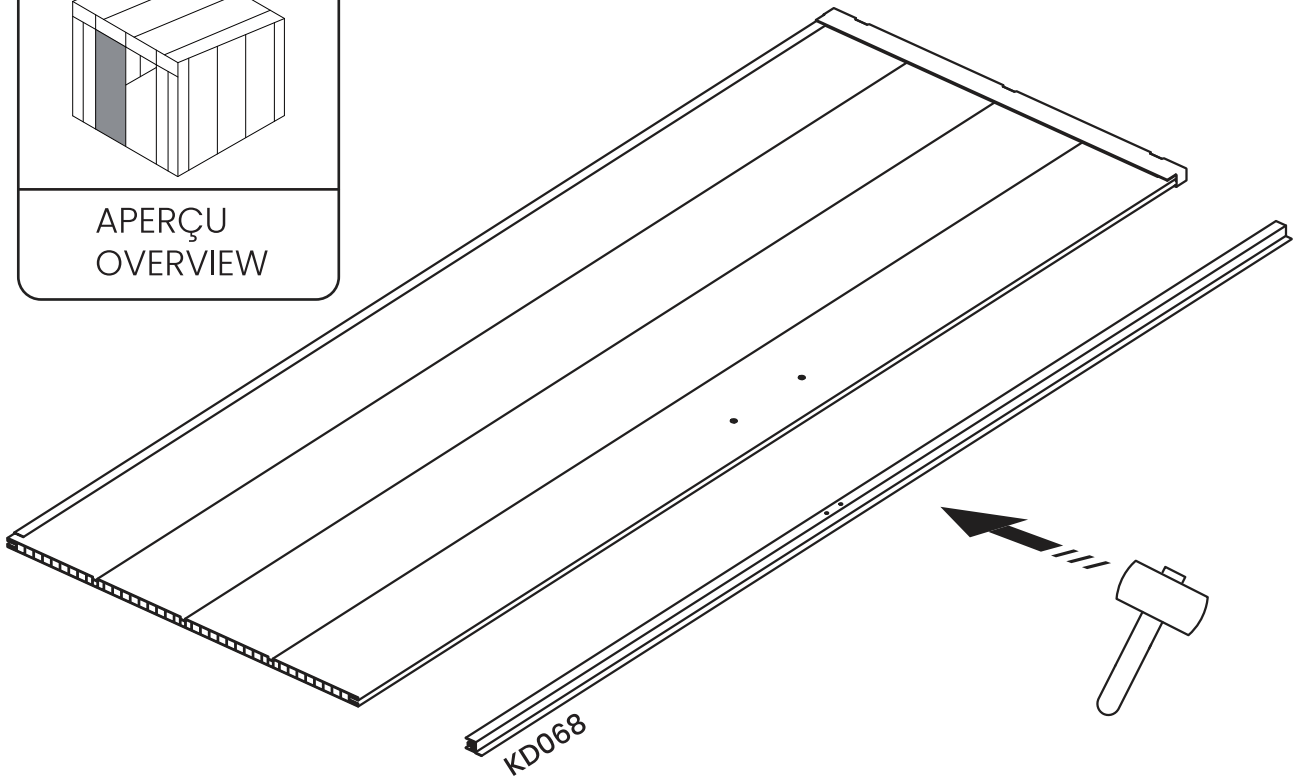
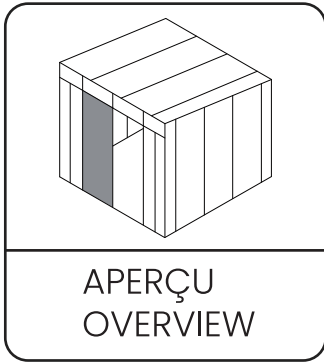

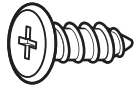

KD083

x14

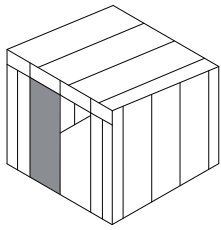

APERÇU
OVERVIEW

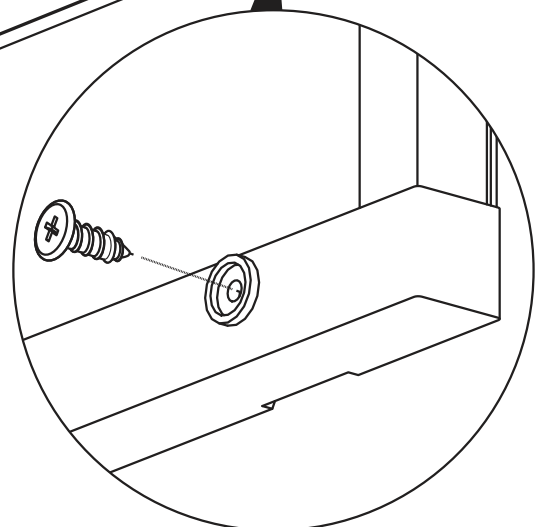
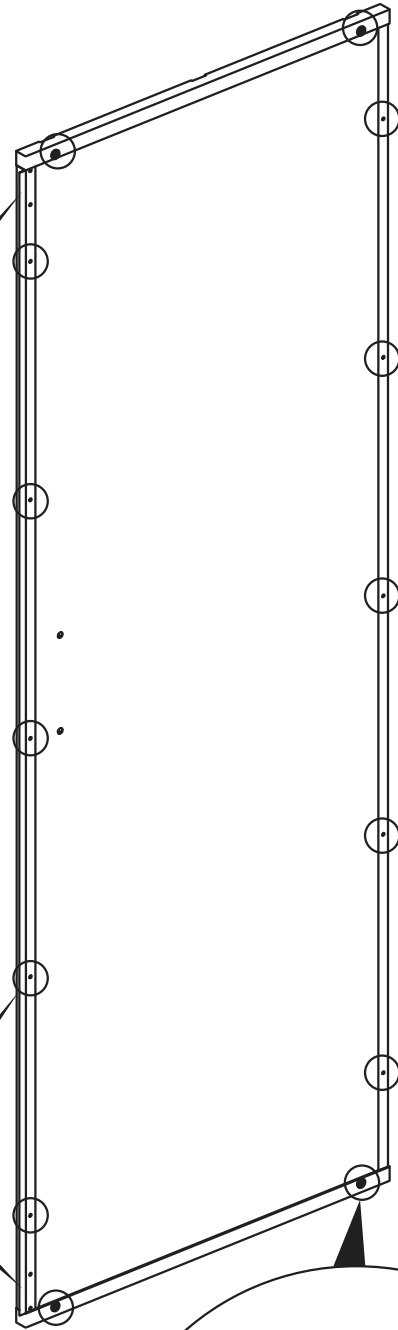
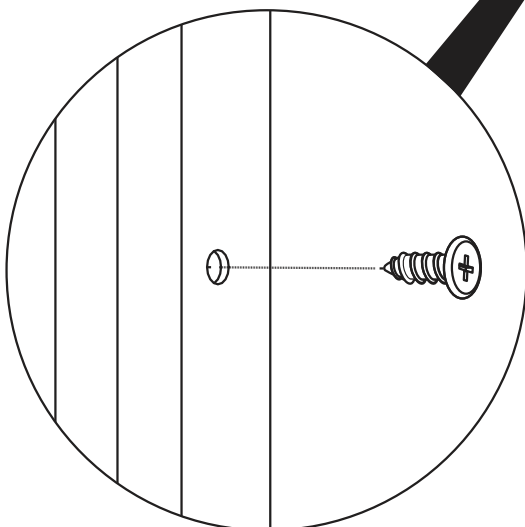
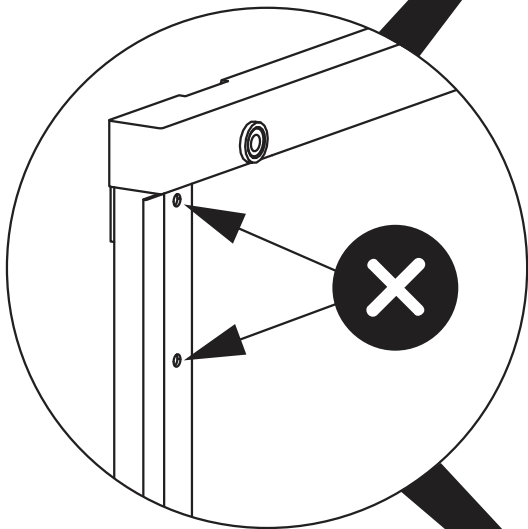

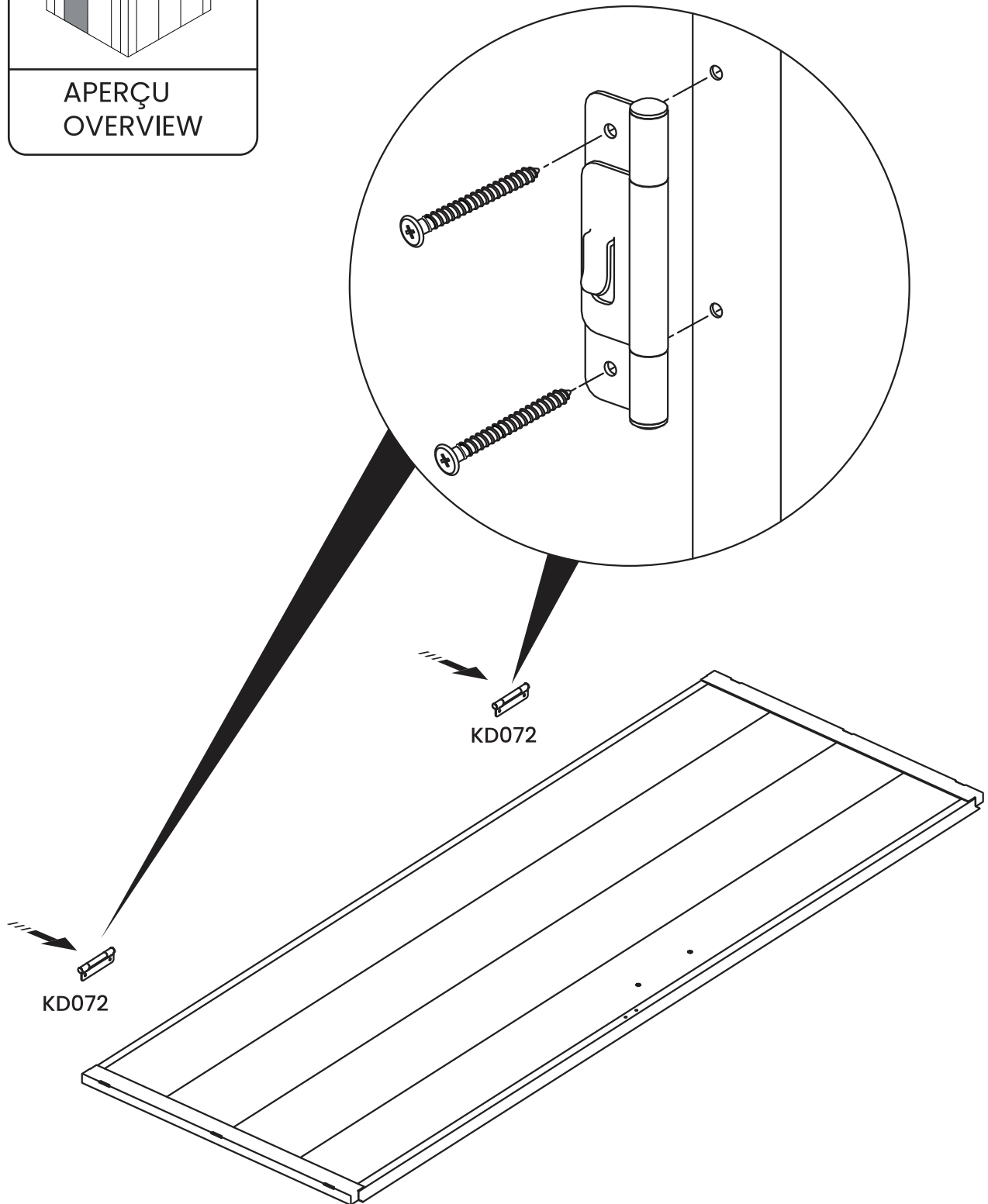
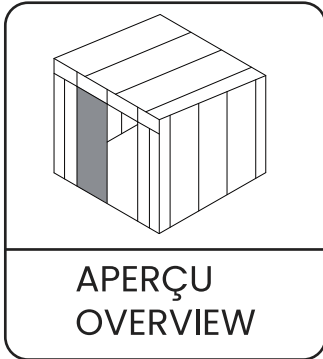

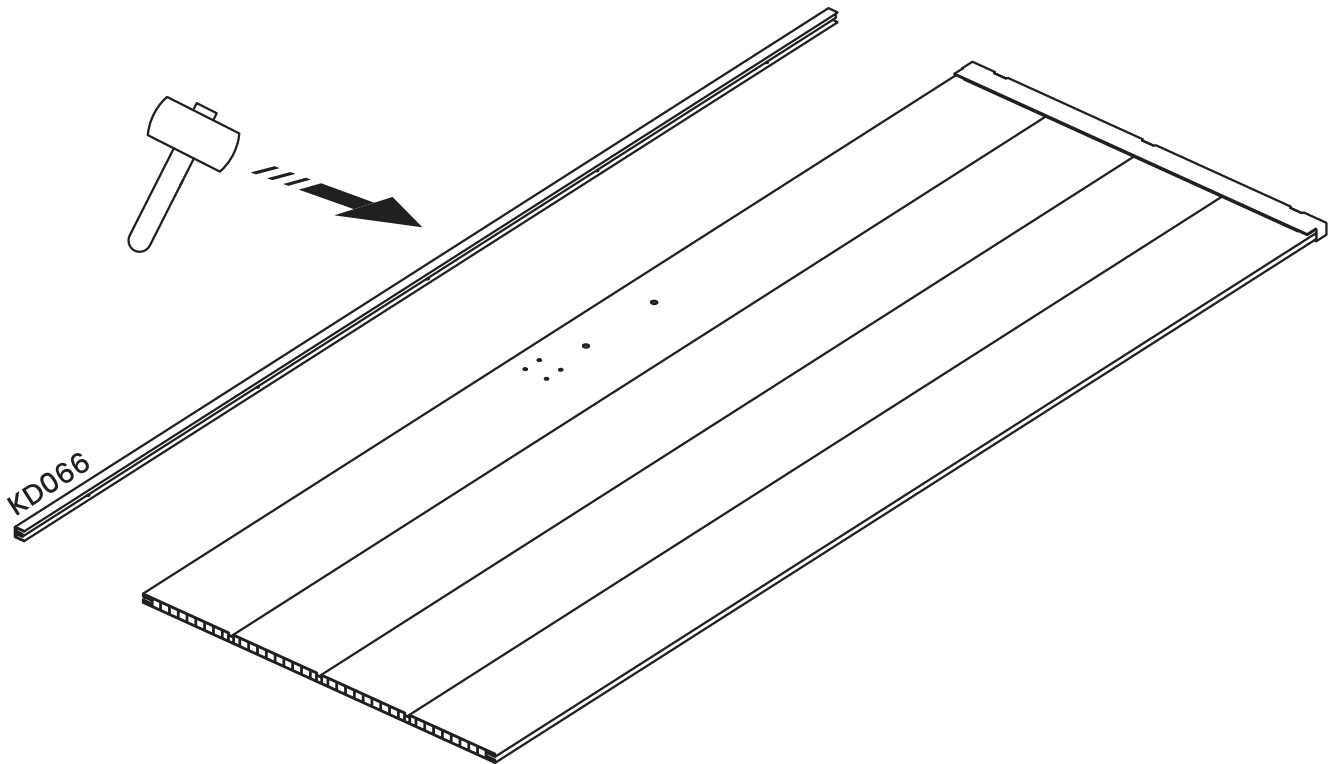
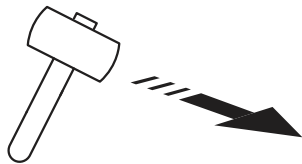
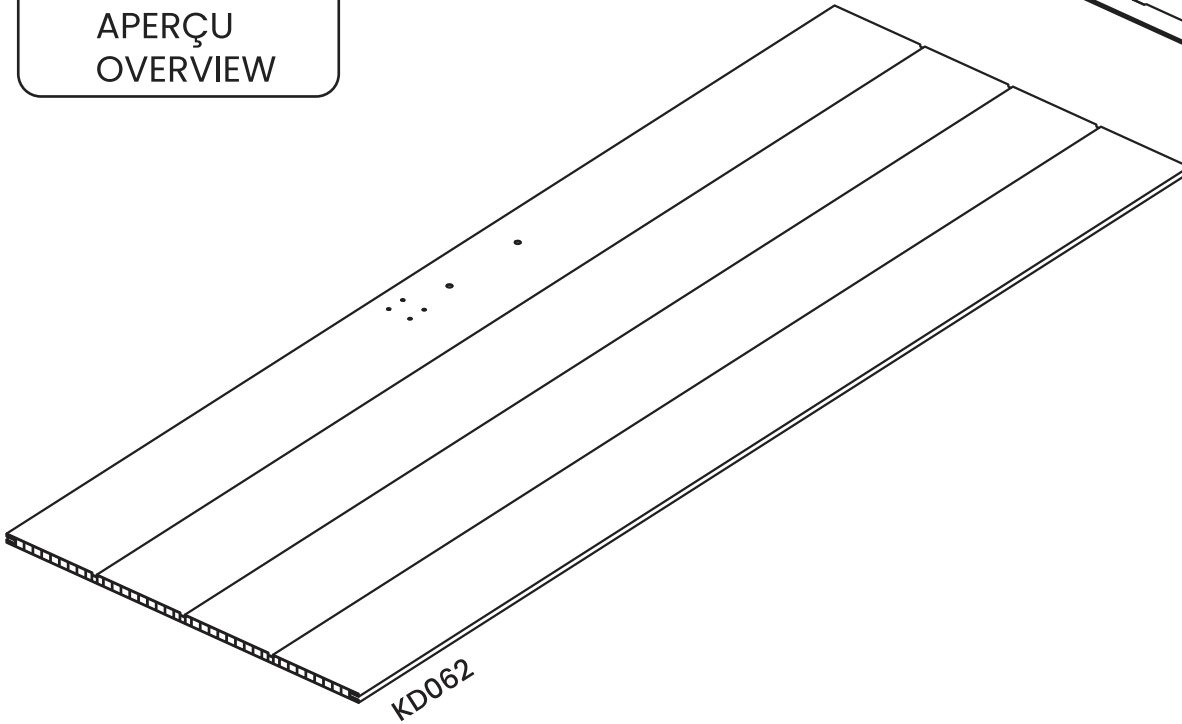
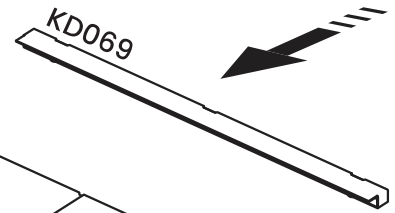
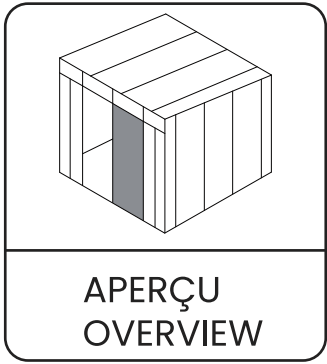

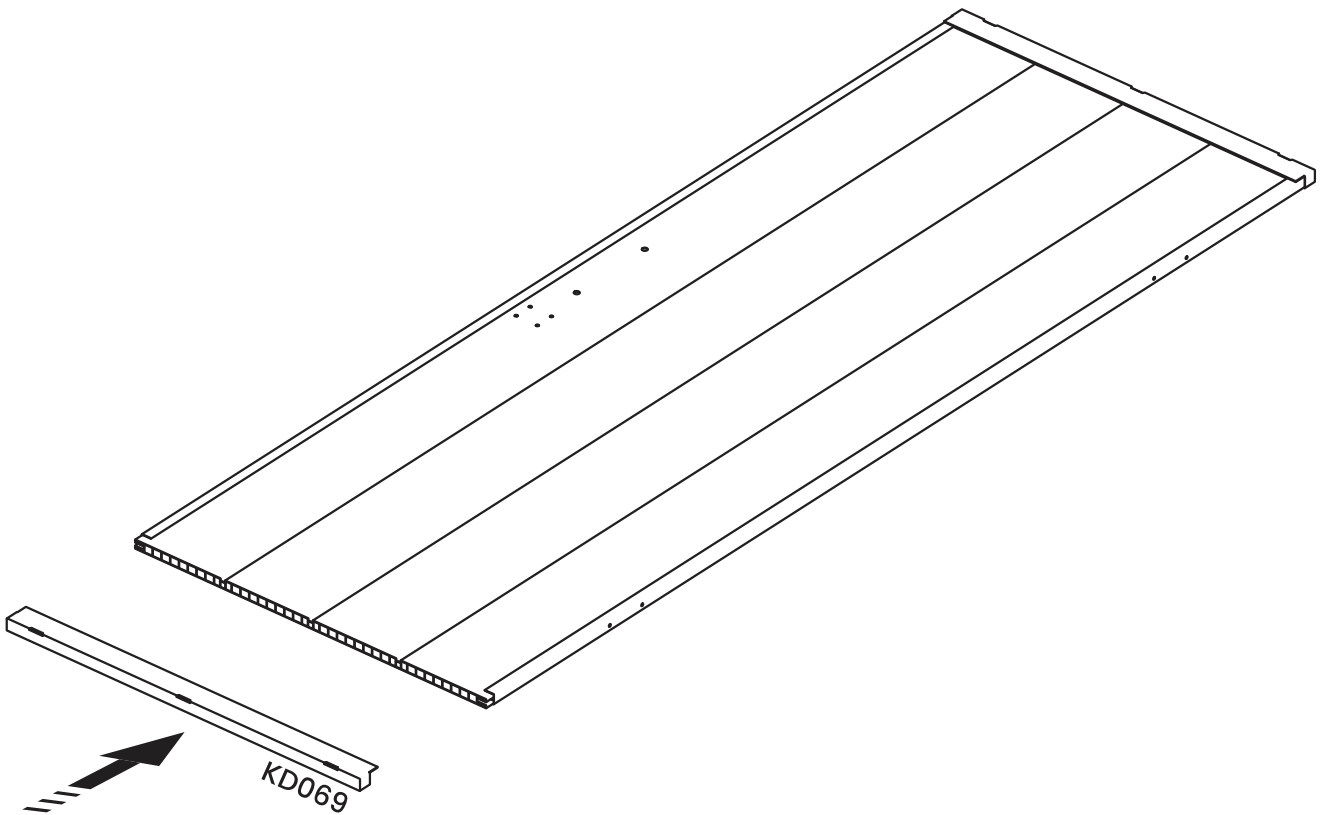
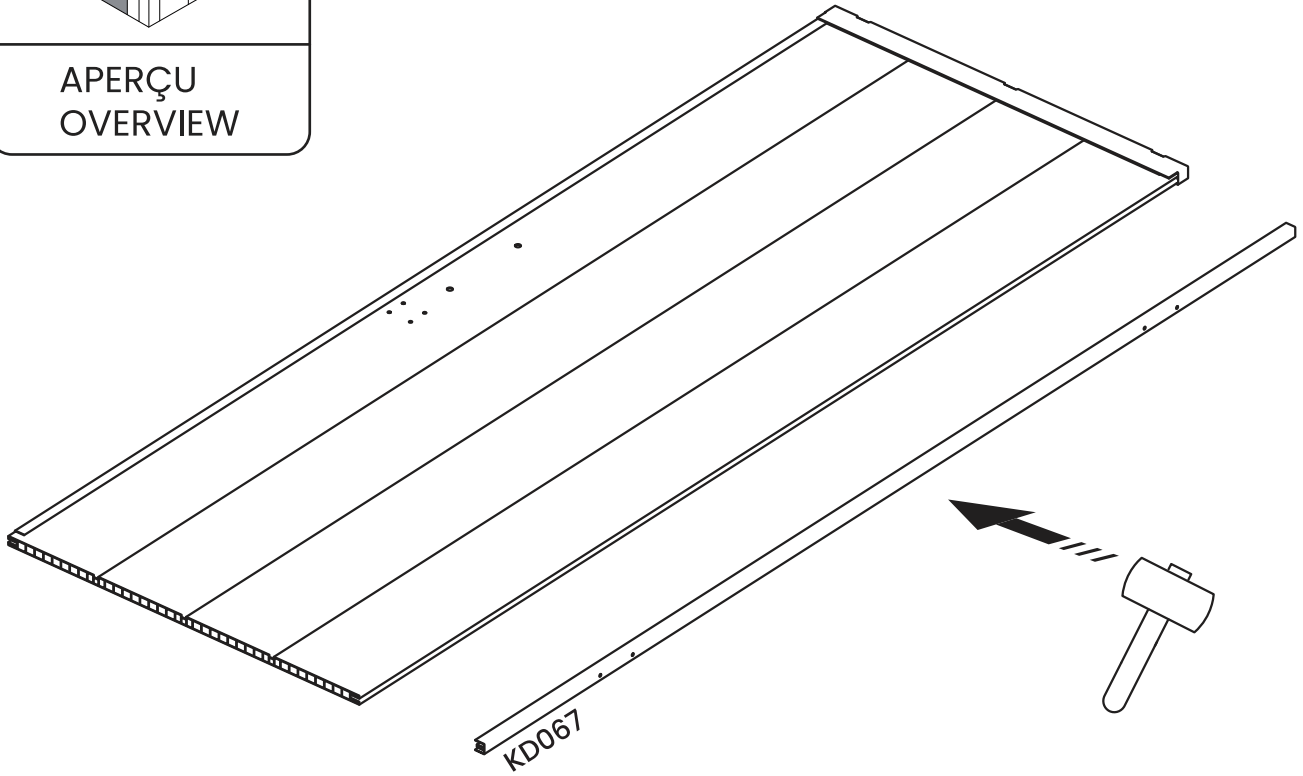
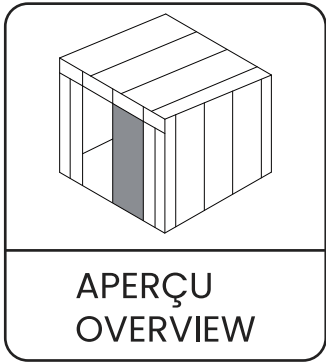

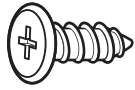

KD083

x14

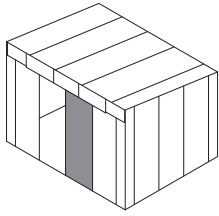

APERÇU
OVERVIEW

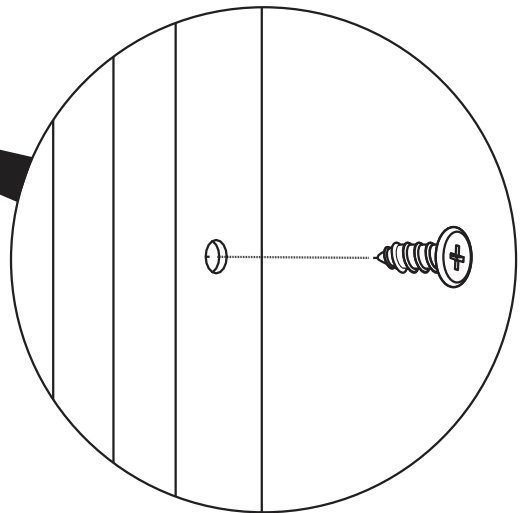
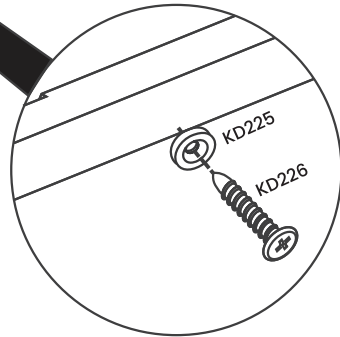
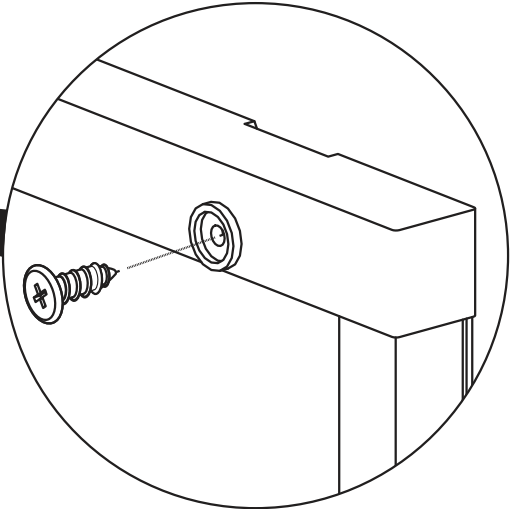
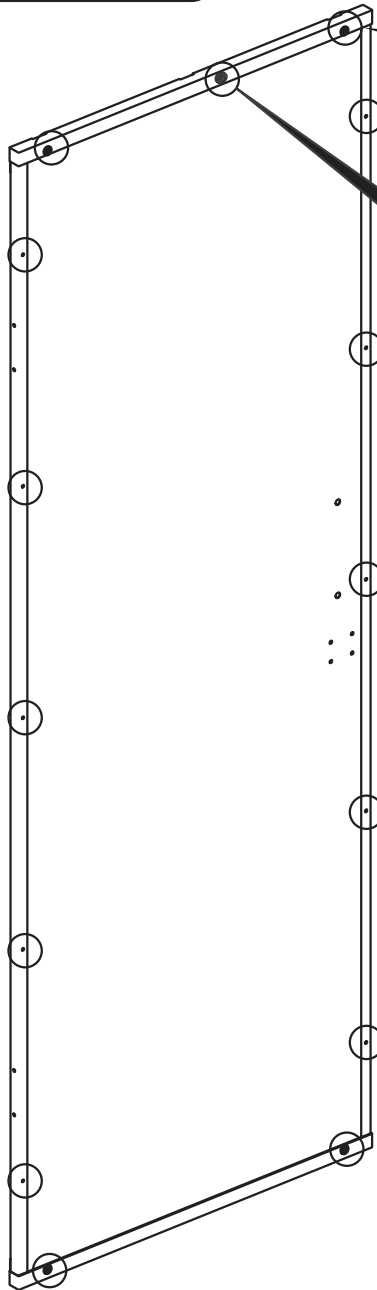

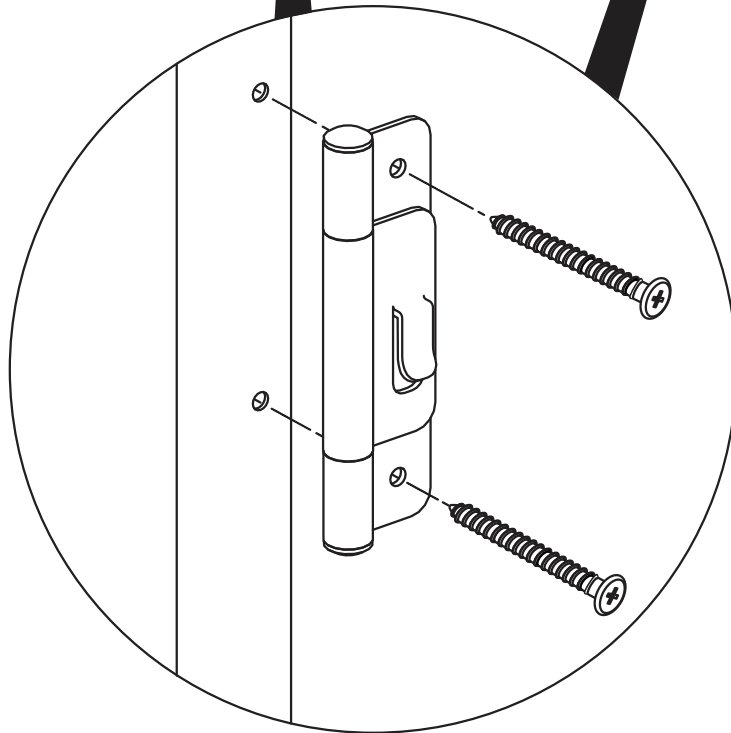
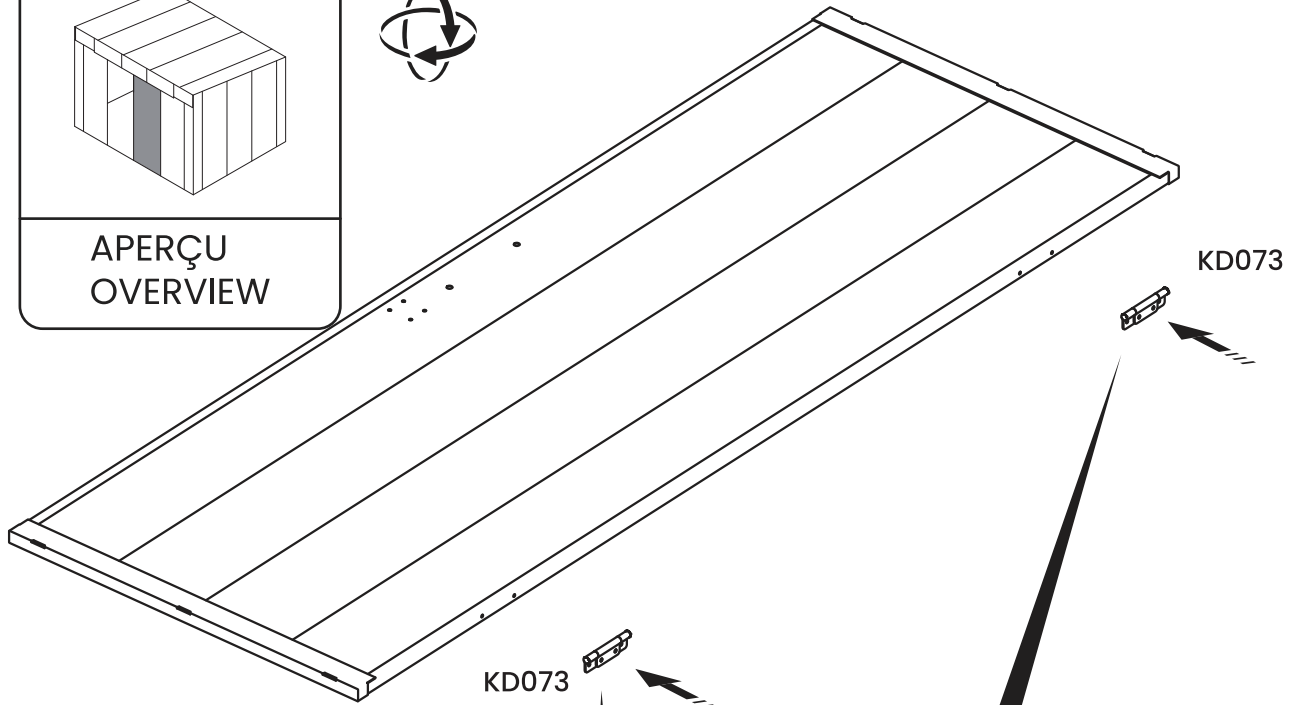
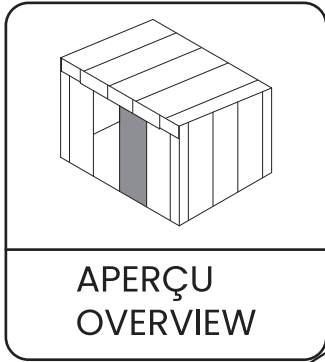

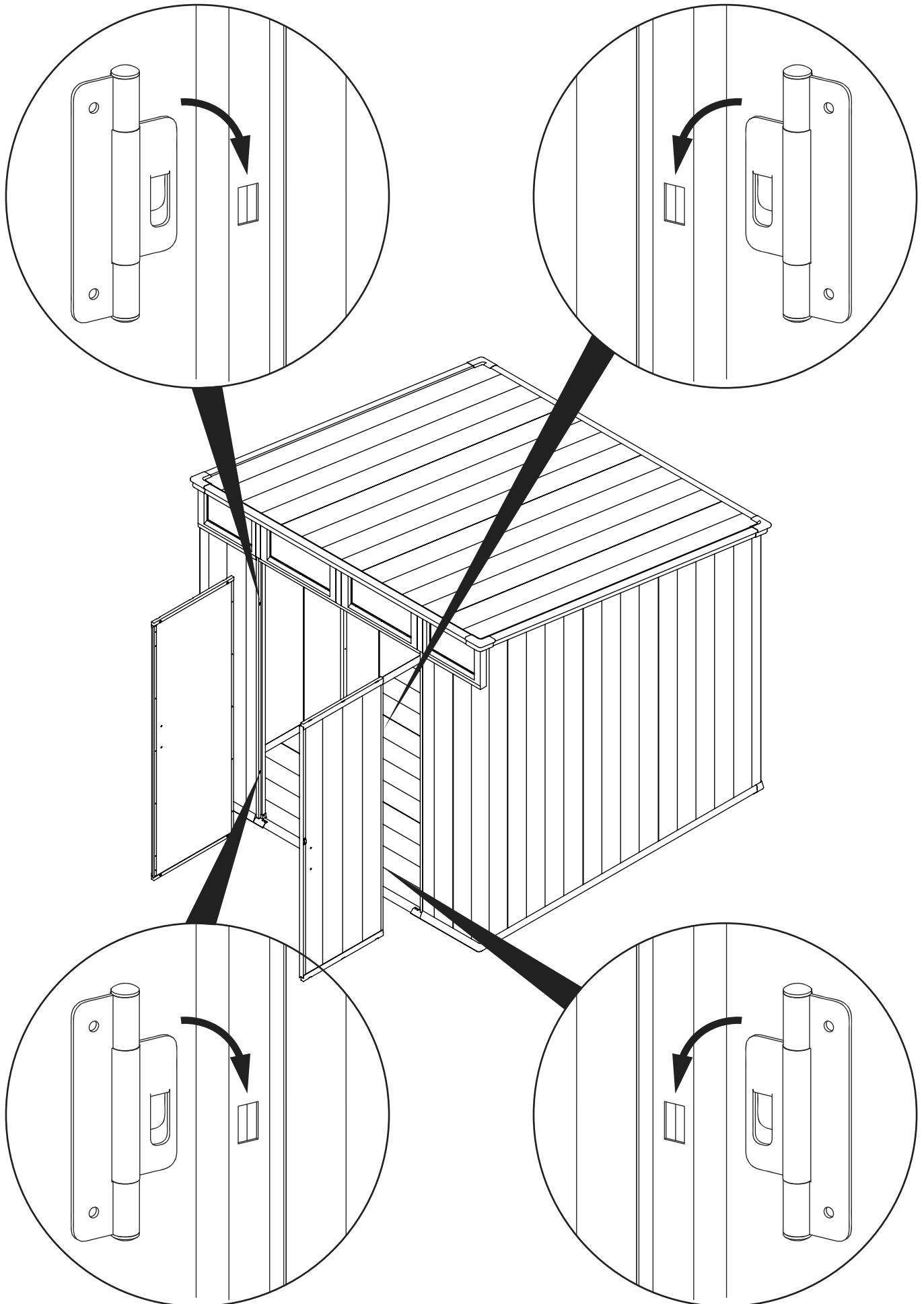

KD070 x2 KD071 x2 KD084 x4

KD079 x2 KD084 x4

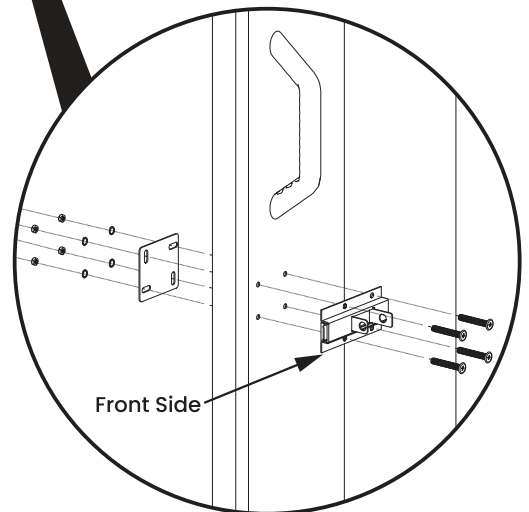
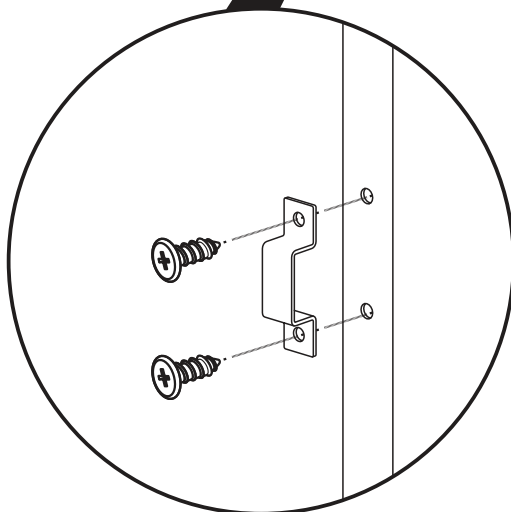
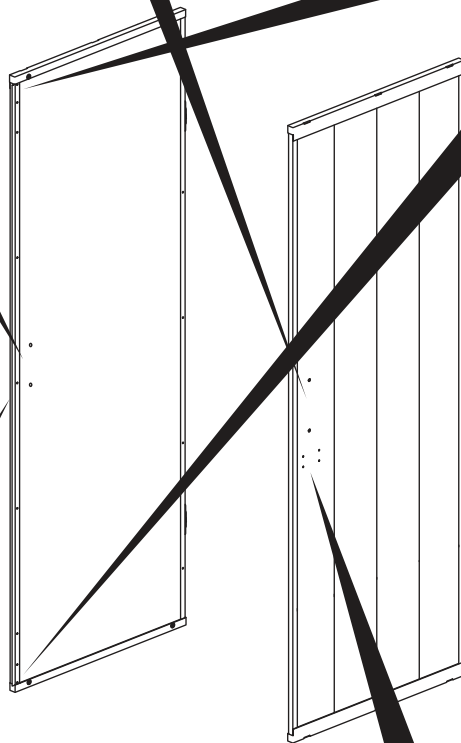
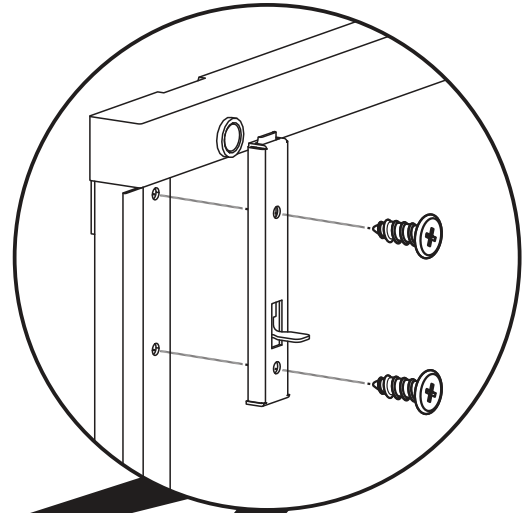
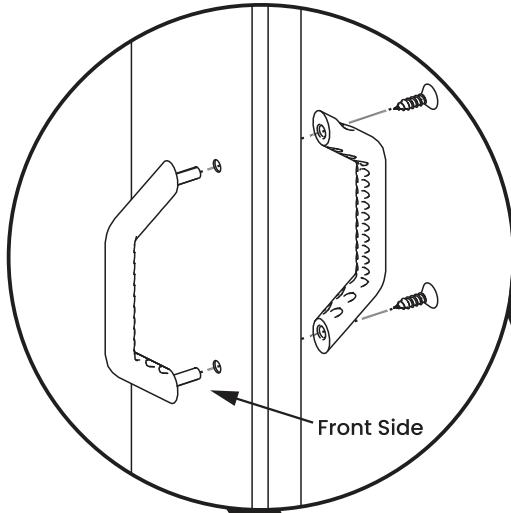

KD076 x1 KD083 x2

KD075 KD077 KD078 x4

Schéma de sécurité / Security Schemes

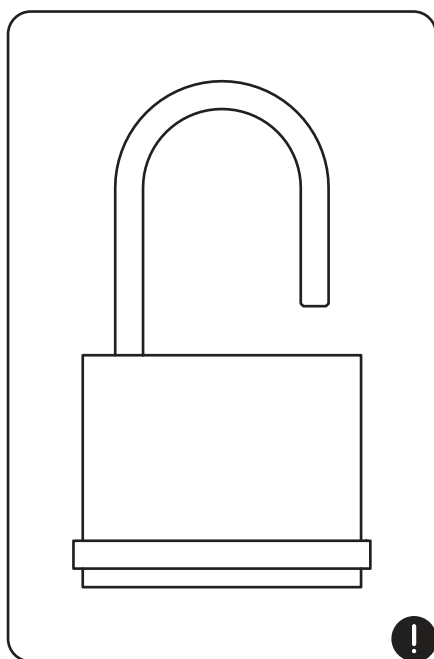
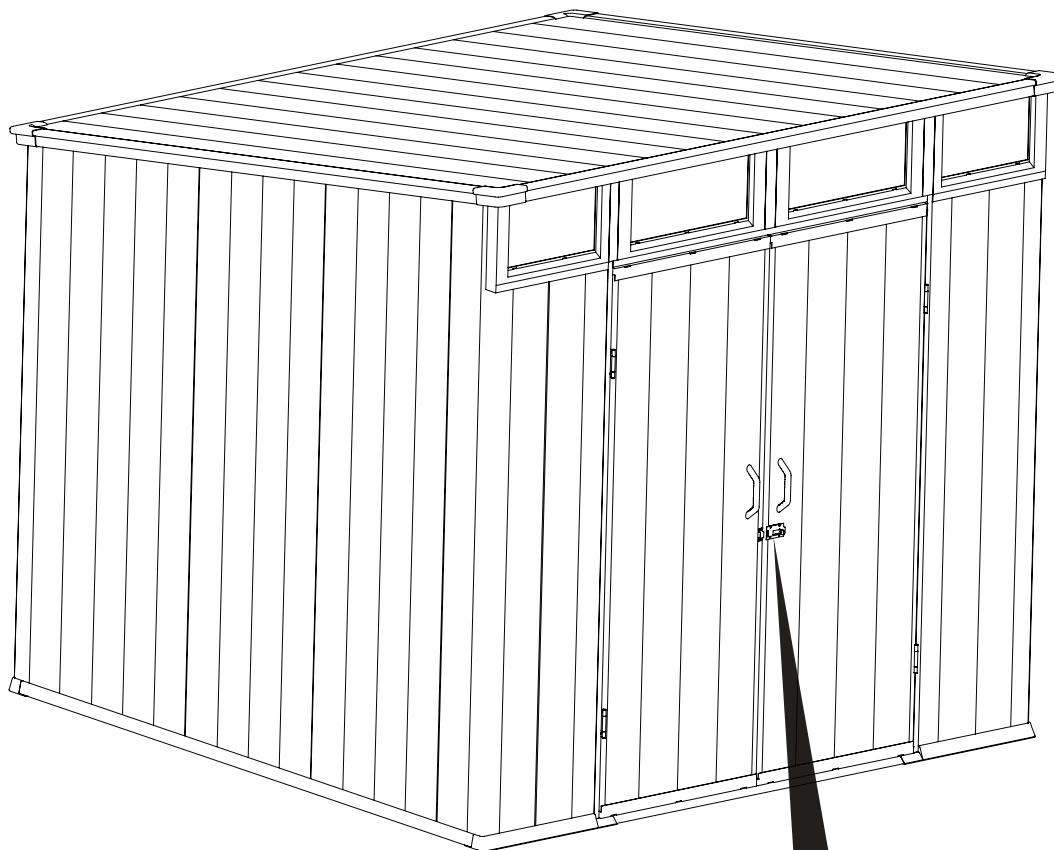

Non inclus / Not included

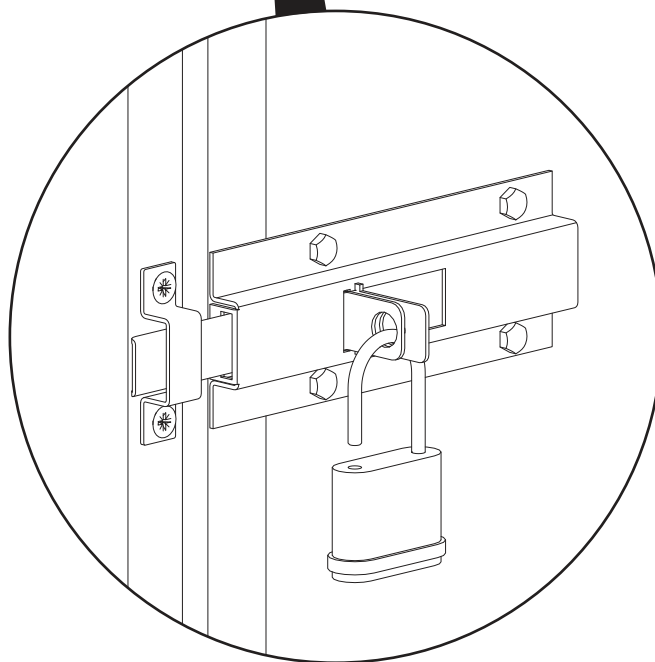



Directives et garantie

Guidelines & Warranty

Conception sans entretien / Maintenance-Free Design

Le cabanon est construit avec un matériau sans entretien qui élimine le besoin de peinture ou de vernis. Bien que les murs puissent être peints pour les personnaliser, aucun traitement supplémentaire n'est nécessaire pour maintenir la durabilité et l'apparence du cabanon.

The Shed is built with a maintenance-free material that eliminates the need for paint or varnish. While the walls can be painted for customization, no additional treatments are required to maintain the shed's durability and appearance.

Murs à peindre uniques / Unique Paintable Walls

Le cabanon est fabriqué à partir d'un composé unique sans entretien qui permet de peindre les panneaux muraux brossés, ce qui vous donne la possibilité de garder le cabanon dans sa couleur d'origine ou de le personnaliser pour l'assortir à votre paysage, à votre terrasse, à votre patio ou à d'autres aménagements extérieurs.

The Shed is crafted from a maintenance-free, unique compound that allows the brushed wall panels to be painted, giving you the option to keep the shed in its original color or to customize it to match your landscape, deck, patio, or other outdoor settings.

Instruction pour la peinture / Painting Instructions

****Type de peinture**** : Utiliser une peinture acrylique à base d'eau pour les applications extérieures. Il est recommandé d'utiliser des teintes claires et solides avec une finition satinée ou semi-brillante. Consulter un spécialiste des couleurs ou un professionnel de la peinture pour obtenir de l'aide dans le choix de la peinture.
****Application**** : Appliquer la peinture au rouleau sur la surface du mur sec. Éviter de peindre les fissures des panneaux muraux qui ressemblent à des poutres.
****Zones à éviter**** : Ne peignez pas les fenêtres, les portes, la poutre de la porte, le toit, le sol ou toute autre partie du cabanon autre que les murs désignés.

****Type of Paint****: Use water-based acrylic paint for exterior applications. Solid, light shades with a satin or semi-gloss finish are recommended. Consult a color specialist or paint professional for assistance in selecting paint.

****Application****: Apply paint with a roller on the dry wall surface. Avoid painting the beam-like crevices within the wall panels.

****Areas to Avoid****: Do not paint the windows, doors, door beam, roof, floor, or any part of the shed other than the designated walls.

Rappel de maintenance / Maintenance Reminder

La peinture peut nécessiter des retouches périodiques ou être repeinte au fil du temps pour conserver l'aspect du cabanon. En suivant ces instructions, vous pouvez personnaliser votre abri de jardin pour qu'il s'intègre parfaitement à votre environnement extérieur.

Painting may require periodic touch-ups or repainting over time to maintain the shed's appearance. Always follow the paint manufacturer's care and safety guidelines before applying. By following these instructions, you can personalize your Shed to seamlessly integrate with your outdoor environment.

Guide pour l'entretien et la sécurité du cabanon / Shed Care and Safety Guidelines

Le cabanon est conçue uniquement à des fins de stockage et n'est pas destinée à être habitée. Veuillez respecter les consignes d'entretien et de sécurité suivantes afin de garantir des performances et une sécurité optimales :

The Shed is designed strictly for storage purposes and is not intended for habitation. Please adhere to the following care and safety guidelines to ensure optimal performance and safety:

****Assemblage et stabilité** / **Assembly and Stability****

- Ancrez le cabanon à un objet fixe ou fixez-le au sol en perçant le sol aux endroits prévus à cet effet et en insérant les vis appropriées.
 - Évitez de monter le cabanon les jours de vent ou de froid.
 - Inspectez régulièrement l'abri pour en vérifier la stabilité et vous assurer que le sol reste plat.
- Anchor the shed to a fixed object or secure it to the ground by drilling at pre-marked locations in the floor and inserting appropriate screws.
- Avoid assembling the shed on windy or cold days.
- Regularly inspect the shed to confirm stability and ensure the ground remains level.

****Manipulation et assemblage** / **Handling and Assembly****

- Soyez prudent avec les pièces à arêtes en acier pour éviter les blessures.
 - N'utilisez que les outils indiqués dans le manuel lors de l'assemblage ou de la manipulation.
 - Éloignez les tondeuses à gazon et les faux mécaniques du cabanon afin d'éviter tout dommage accidentel.
 - Portez des lunettes de sécurité et respectez les instructions du fabricant lorsque vous utilisez des outils électriques.
- Exercise caution with steel-edged parts to prevent injury.
- Only use the tools listed in the manual during assembly or handling.
- Keep lawnmowers and mechanical scythes away from the shed to avoid accidental damage.
- Wear safety goggles and adhere to manufacturer instructions when operating power tools.

****Nettoyage et entretien** / **Cleaning and Maintenance****

- Nettoyez le cabanon avec un tuyau d'arrosage ou une solution détergente douce. Évitez d'utiliser des brosses dures ou des nettoyants abrasifs, y compris des dégraissants et des produits à base d'huile ou d'acétone, car ils risquent de tacher ou d'endommager le matériau.
- Clean the shed with a garden hose or a mild detergent solution. Avoid using stiff brushes or abrasive cleaners, including degreasers and oil- or acetone-based products, as they may stain or damage the material.

****Précautions de stockage** / **Storage Precautions****

- Ne stockez pas d'objets chauds, tels que des grils ou des chalumeaux récemment utilisés, et évitez de stocker des produits chimiques volatils.
 - Ne placez pas d'objets lourds contre les murs, car cela pourrait provoquer des déformations.
 - Débarrassez le toit de la neige et des feuilles qui s'y sont accumulées afin d'éviter tout dommage et de garantir un accès sûr
- Do not store hot items, such as recently used grills or blowtorches, and avoid storing volatile chemicals.
- Refrain from placing heavy objects against the walls, as this could cause distortion.
- Keep the roof clear of accumulated snow and leaves to prevent damage and maintain safe access..

****Considérations météorologiques** / **Weather Considerations****

- Lorsque vous placez le cabanon tenez compte de la direction du vent pour minimiser l'exposition, en particulier du côté de la porte. Gardez les portes fermées et verrouillées lorsque l'abri n'est pas utilisé afin d'éviter les dommages causés par le vent.
 - Évitez de vous tenir sur le toit.
- When positioning the shed, consider wind direction to minimize exposure, particularly on the door side. Keep doors closed and locked when the shed is not in use to prevent wind damage.
- Avoid standing on the roof.

****Autorisations** / **Permits****

- Consultez les autorités locales pour savoir si un permis est nécessaire pour l'installation du cabanon dans votre région.
- Consult with local authorities to determine if permits are required for shed installation in your area.

En suivant ces conseils, vous contribuerez à faire de votre cabanon une solution de stockage sûre et fonctionnelle.

By following these guidelines, you'll help ensure that your Shed remains a safe and functional storage solution.

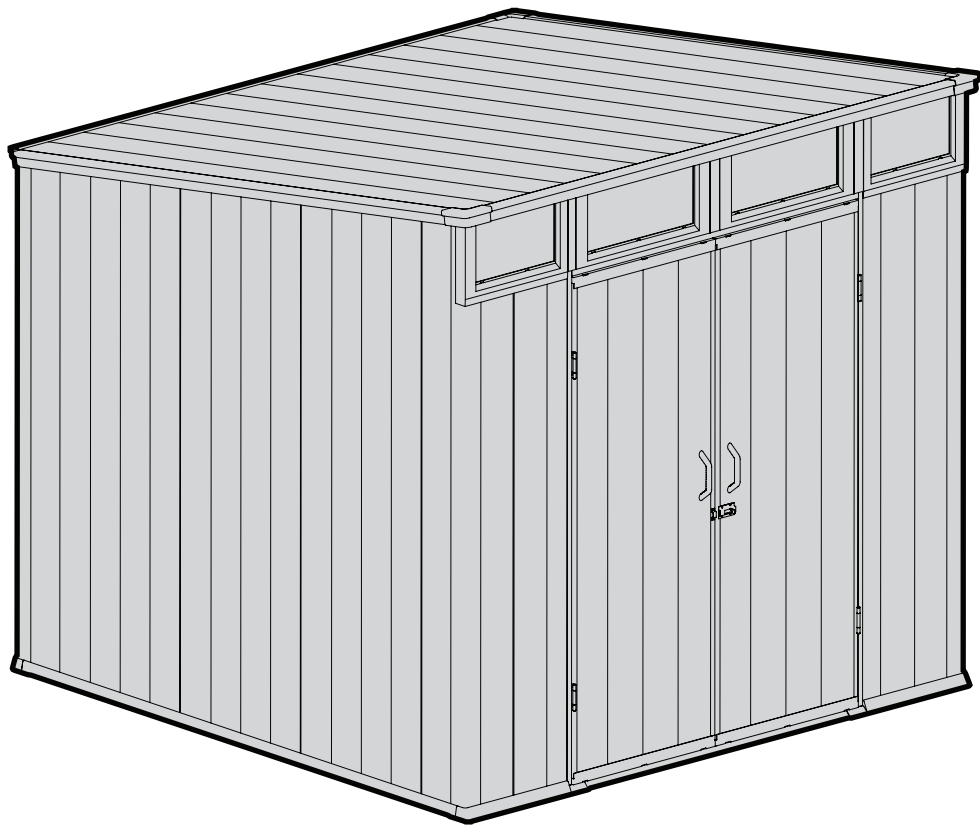

Version 1.0
Revised 20.Feb.2025