

**CABANON**  
DESIGN

# *1 Versant 10'x8'*

*1-sided shed 10'x8'*

***Guide d'utilisation / Manual***

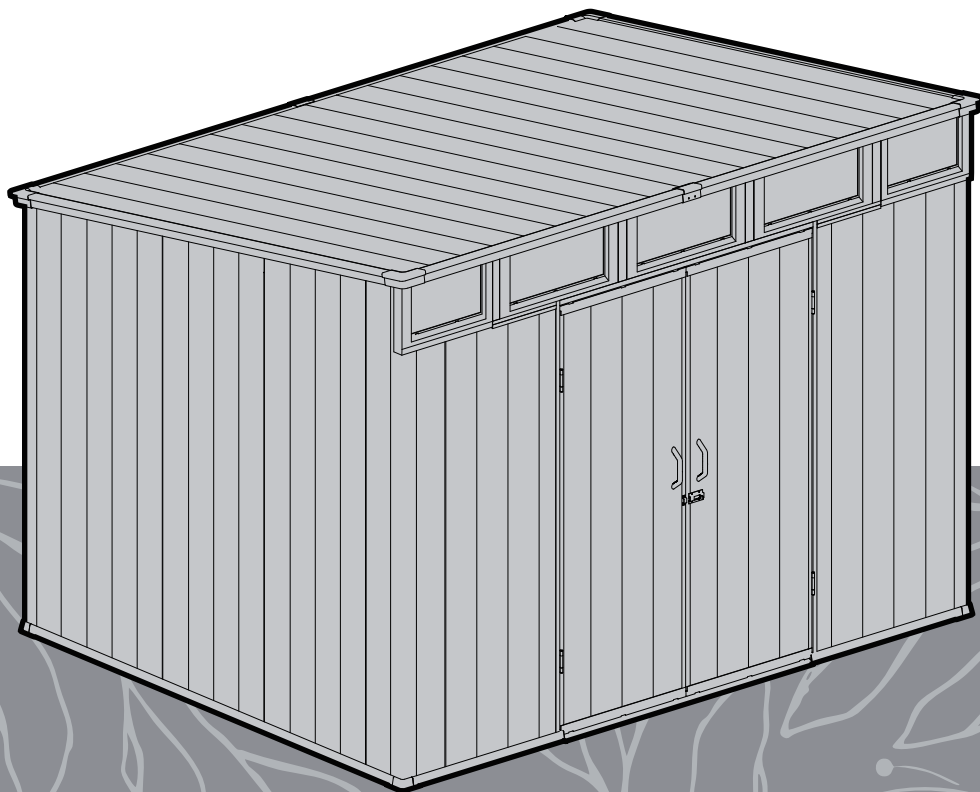

Version 1.0  
Revised 19.Feb.2025



# SOMMAIRE / CONTENT

<b>AVANT L'ASSEMBLAGE ILLUSTRATION</b> BEFORE ASSEMBLE ILLUSTRATION .....	<b>01</b>
<b>LISTE DES PIÈCES / PARTS LIST</b> .....	<b>03</b>
<b>ASSEMBLAGE DU PLANCHER</b> FLOOR ASSEMBLY .....	<b>11</b>
<b>ASSEMBLAGE DU CADRE</b> FRAME ASSEMBLY .....	<b>23</b>
<b>ASSEMBLAGE DES MURS</b> WALL ASSEMBLY .....	<b>33</b>
<b>ASSEMBLAGE DES FENÊTRES</b> WINDOW ASSEMBLY .....	<b>43</b>
<b>ASSEMBLAGE DU TOIT</b> ROOF ASSEMBLY .....	<b>51</b>

<b>FIXATION COMPLÈTE</b>	
WHOLE FIXATION .....	<b>61</b>
<b>ASSEMBLAGE DE LA PORTE</b>	
DOOR ASSEMBLY .....	<b>69</b>
<b>DIRECTIVES ET GARANTIE</b>	
GUIDELINES & WARRANTY .....	<b>83</b>

# Préparation du site / Site Preparation

Niveler la surface du sol  
Level the ground surface

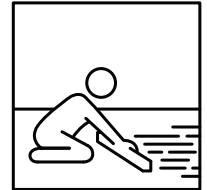
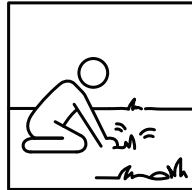

## Recommandation de la plateforme Platform Recommendation

### Option A

Bois / Wooden

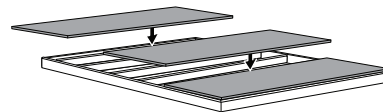

### Option B

Béton / Concrete

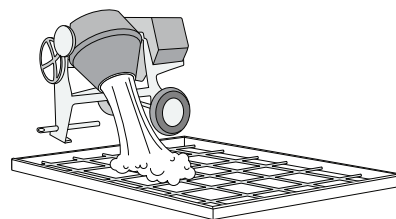

### Option C

Sol / Soil

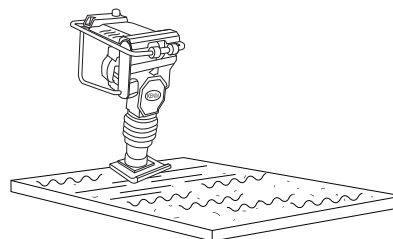

# Avant de commencer l'assemblage

## Before Starting Assembly

Lisez les consignes d'entretien et de sécurité à la fin de ce manuel. Vérifiez qu'aucune pièce ne manque ou n'est endommagée avant de commencer ou d'organiser l'assemblage. Passez en revue toutes les instructions d'assemblage. Assemblez toutes les pièces conformément aux instructions de ce manuel.

Ne sautez aucune étape.

Read the care and safety guidelines at the end of this manual. Check to ensure that there are no missing or damaged parts before starting or arranging assembly. Review all assembly instructions. Assemble all the parts according to the directions in this manual. Do not skip any steps.

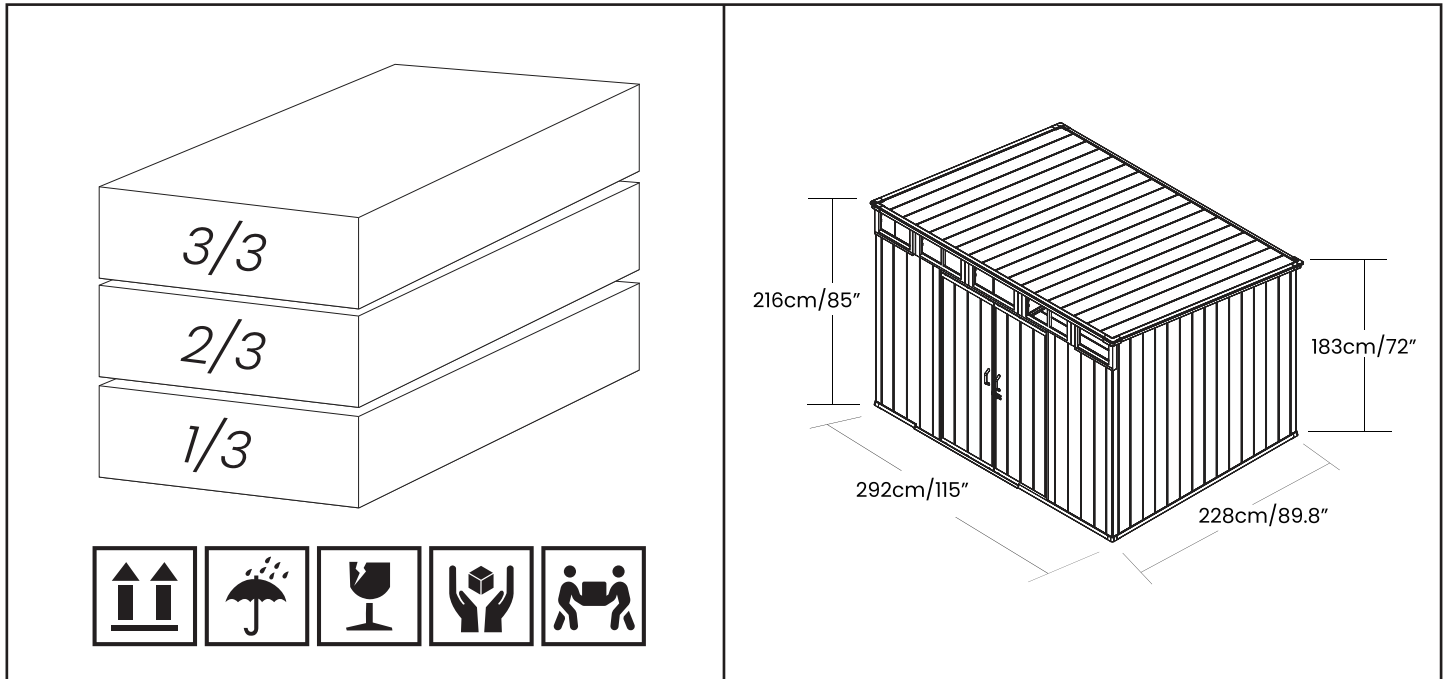

Pour l'accès extérieur lors de l'assemblage, veillez à laisser un espace suffisant. Pour l'accès extérieur lors du montage, veillez à laisser suffisamment d'espace.

For external access during assembly, make sure to leave enough room. For external access during assembly, make sure to leave enough room.

<p><b>2 Personnes requises.</b> 2 People Required.</p>	
<p><b>Outils nécessaires.</b> Tools needed.</p>	

# Liste des pièces / Parts List



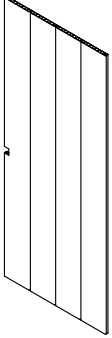
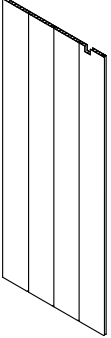
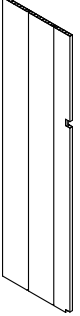
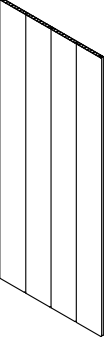
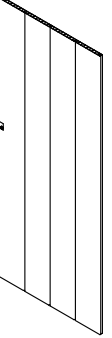
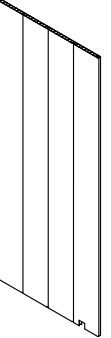
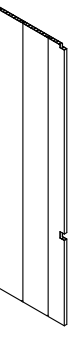
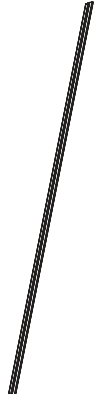
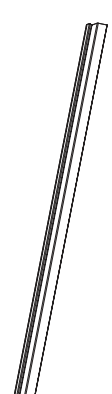
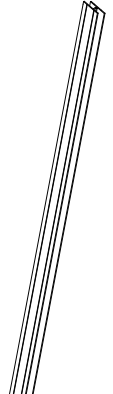
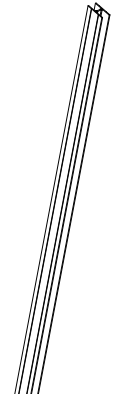
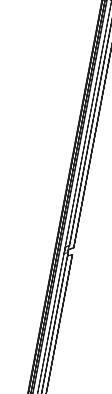
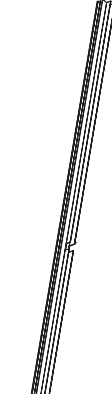
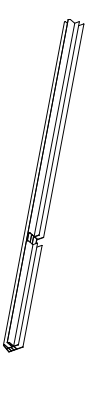
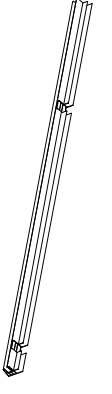
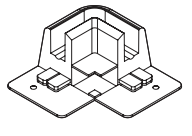
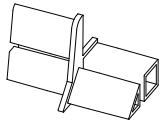
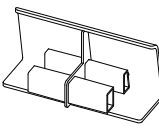
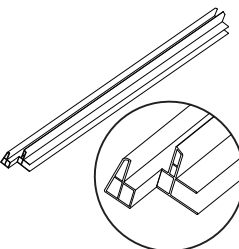
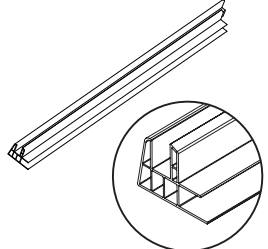

Retirez toutes les pièces de l'emballage et étalez-les sur une surface de travail propre. Des lettres de code sont imprimées sur chaque pièce pour en faciliter l'identification.

Remove all parts from the package(s) and spread them out on a clean work surface. Code letters are imprinted on each part for easy identification.

## Pièces de plancher / Floor Parts

KD194	KD195	KD199	KD198	KD196	KD197	KD200	
							
			x2				
KD102	KD009	KD201	KD202	KD103	KD104	KD223	KD224
							
x6							
KD015	KD205	KD206	KD203	KD204			
							
x4	x2						

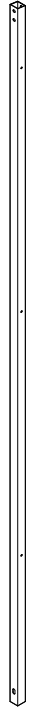
# Pièces du cadre / Frame Parts

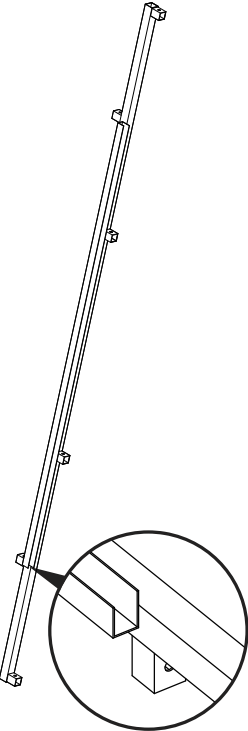
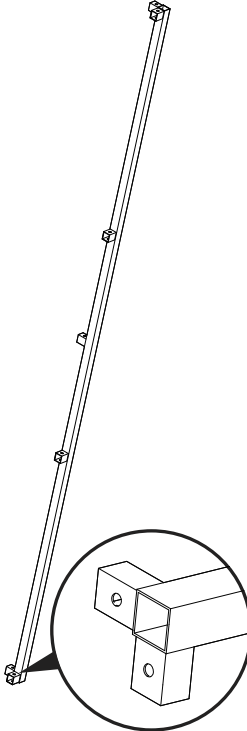
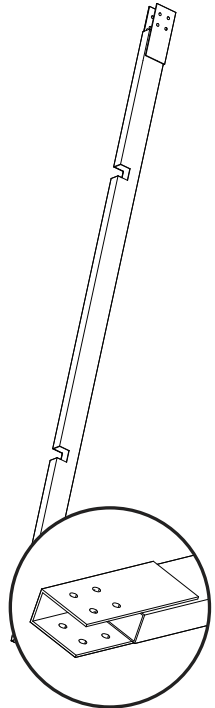
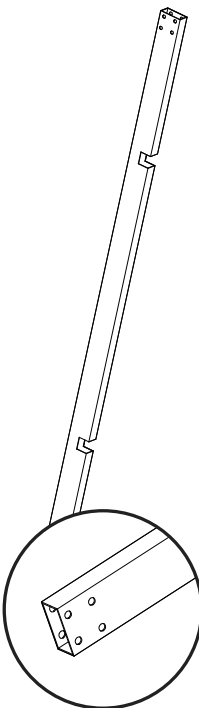
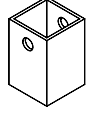
KD207	KD208	KD157	KD158	KD190	KD162
		 <p data-bbox="734 1086 774 1120">x3</p>	 <p data-bbox="973 1086 1013 1120">x2</p>	 <p data-bbox="1212 1086 1252 1120">x4</p>	 <p data-bbox="1460 1086 1500 1120">x4</p>
KD209	KD210	KD211	KD212	KD029	
				 <p data-bbox="1460 1982 1500 2016">x7</p>	



# Pièces pour le mur / Wall Parts

KD165	KD166	KD167	KD168	KD169	KD215	KD216
KD170	KD171	KD172	KD173	KD174	KD175	KD217
KD176	KD177	KD178	KD179	KD180	KD181	
1784 mm x3	1983 mm x2	1897 mm x2		KD191	KD192	
						x2



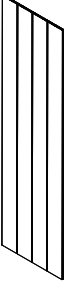
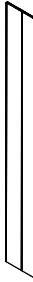
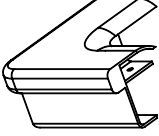
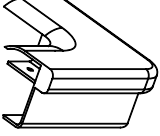
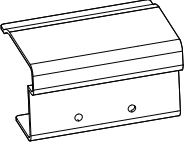
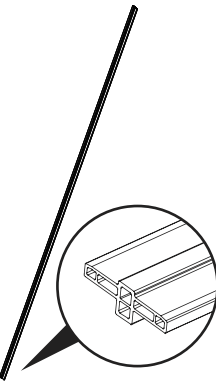
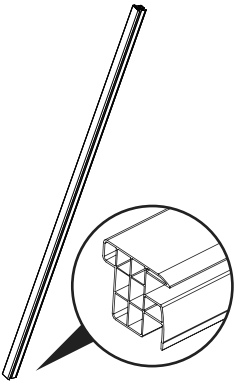
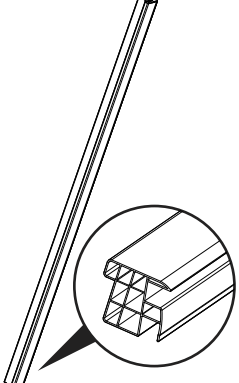
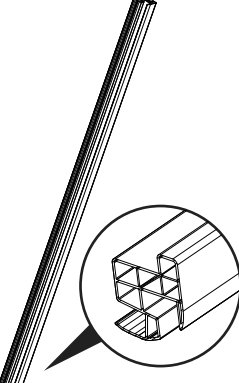
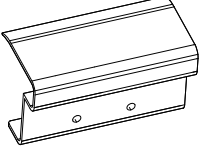

# Pièces de toit / Roof Parts

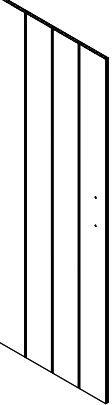
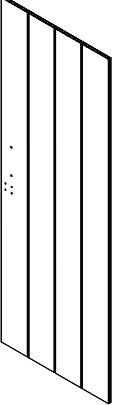
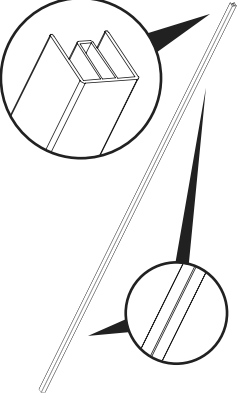
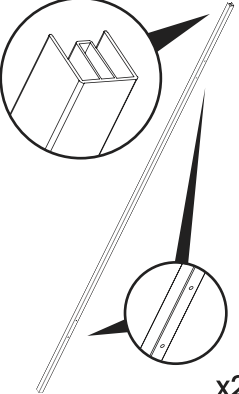
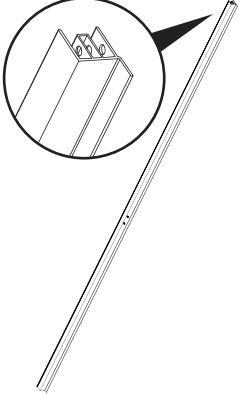
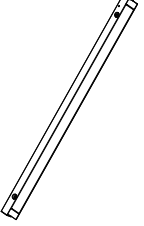
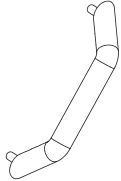
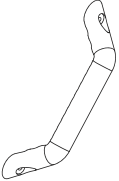
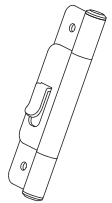
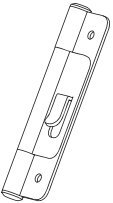
KD182  x4	KD218  x2	KD184  x2	KD185  x2	KD220  x2
KD186  2304 mm x4	KD187  2248 mm x2	KD219  1110 mm x2	KD221  1110 mm x2	KD222  x2

# Door Parts

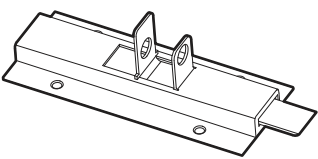
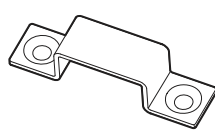
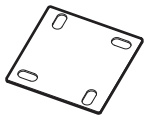
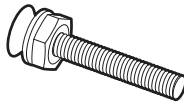
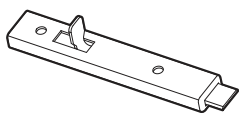
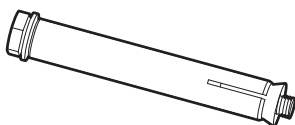
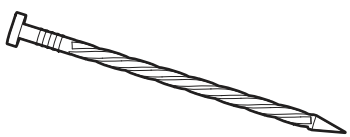
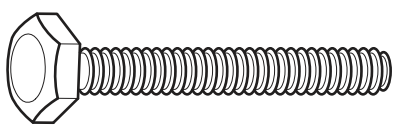
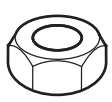
KD061  x4	KD062  x2	KD066  x2	KD067  x2	KD068  x2
KD069  x4	KD070  x2	KD071  x2	KD072  x2	KD073  x2

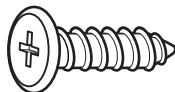
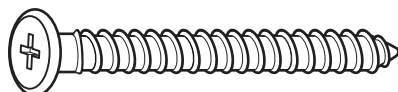
# Matériel / Hardware

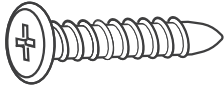
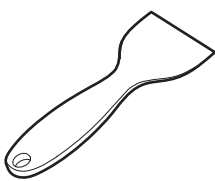
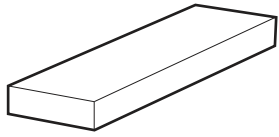
KD075		KD076		KD077	
					
KD078		KD079		KD080	
 x4		 x2		 x7	
KD118		KD081		KD082	
 x7		 x36		 x36	
KD083		KD084		KD085	
 x211		 x42		 x51	
KD225	KD226	KD119	KD120		
					

Assurez-vous que toutes les pièces sont complètes avant de procéder à l'installation.

Ensure that all parts are complete before installation.

# Outil supplémentaire Illustration

## Extra Tool Illustrate

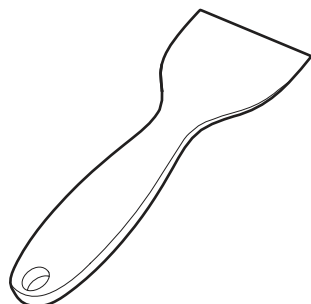

**KD119**

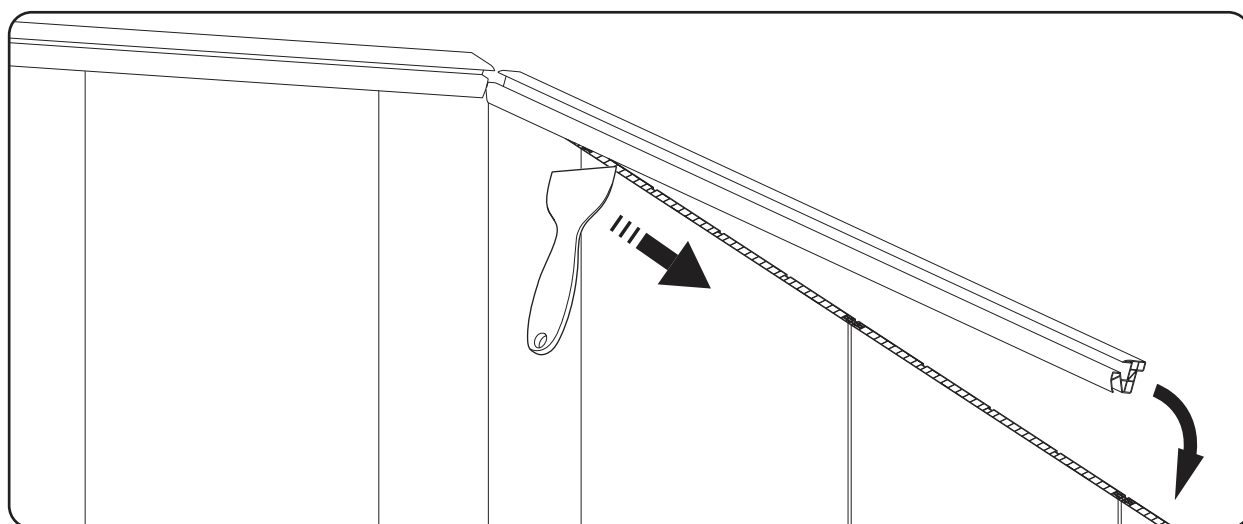
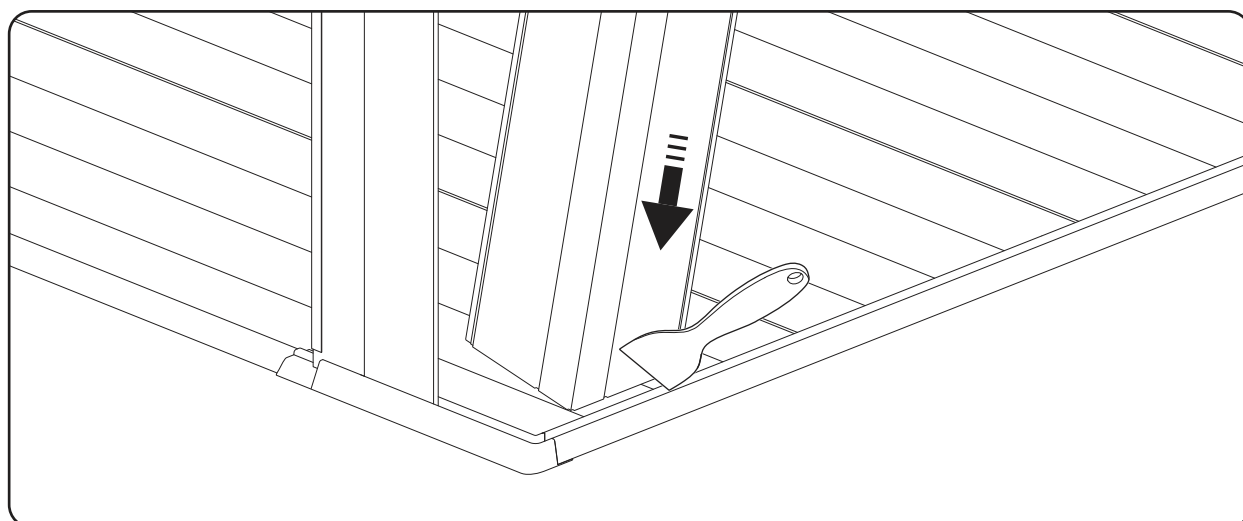

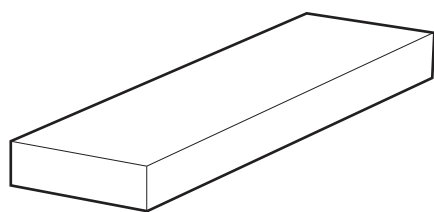

# KD120

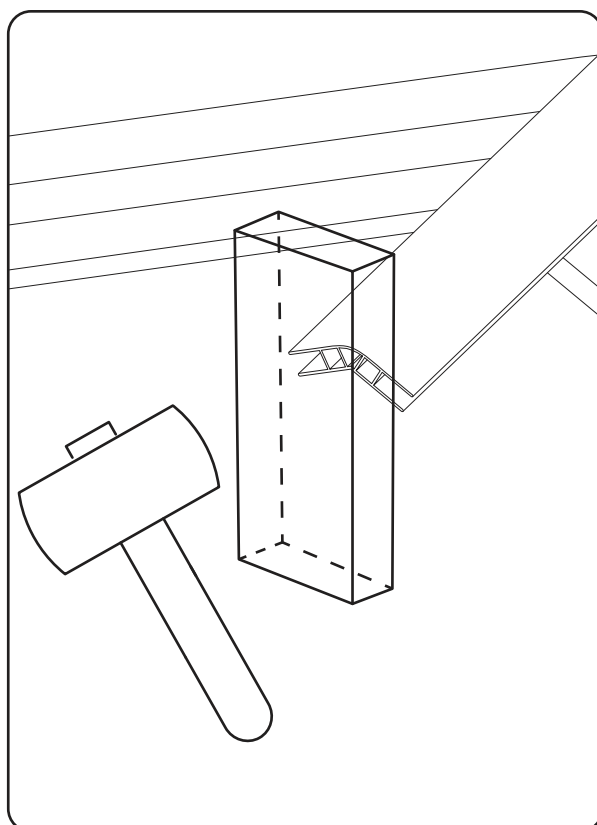
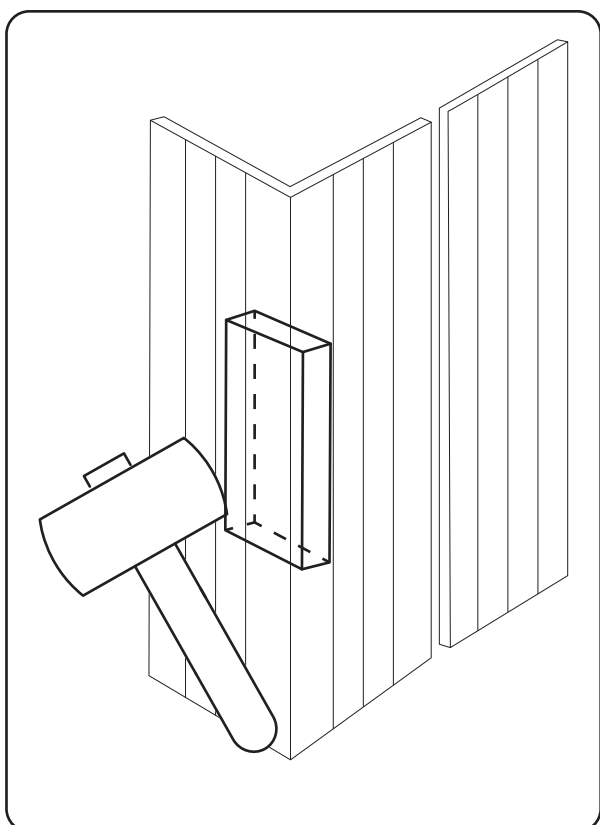
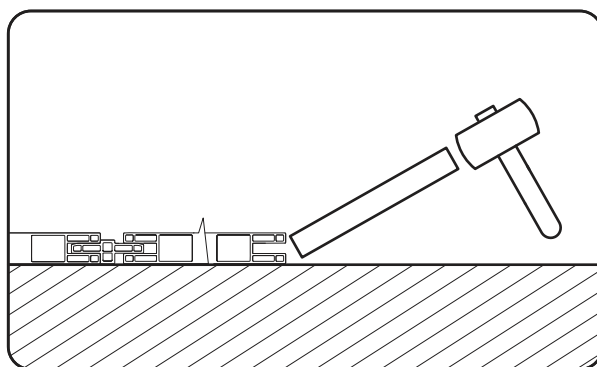
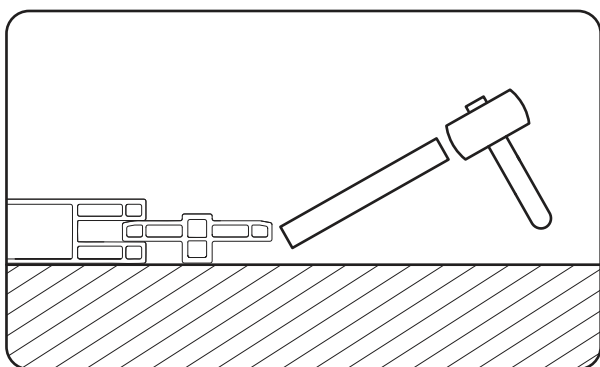



# Assemblage du plancher

## Floor Assembly

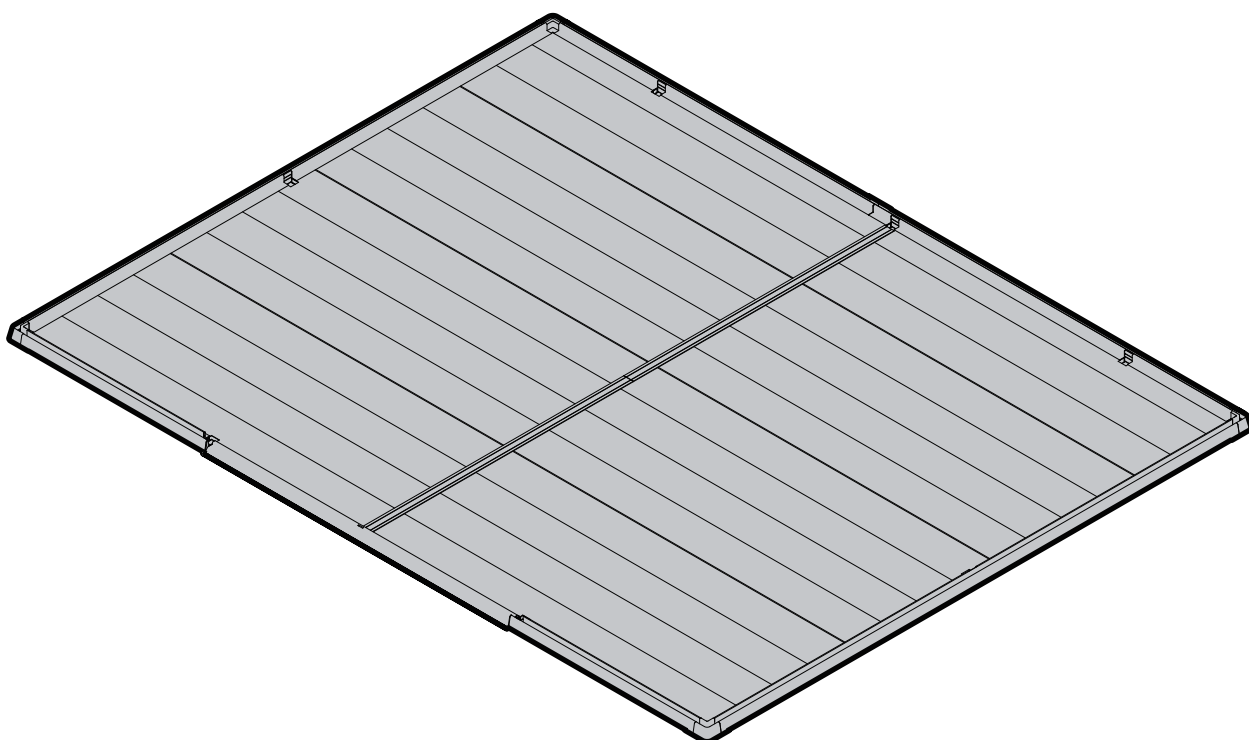

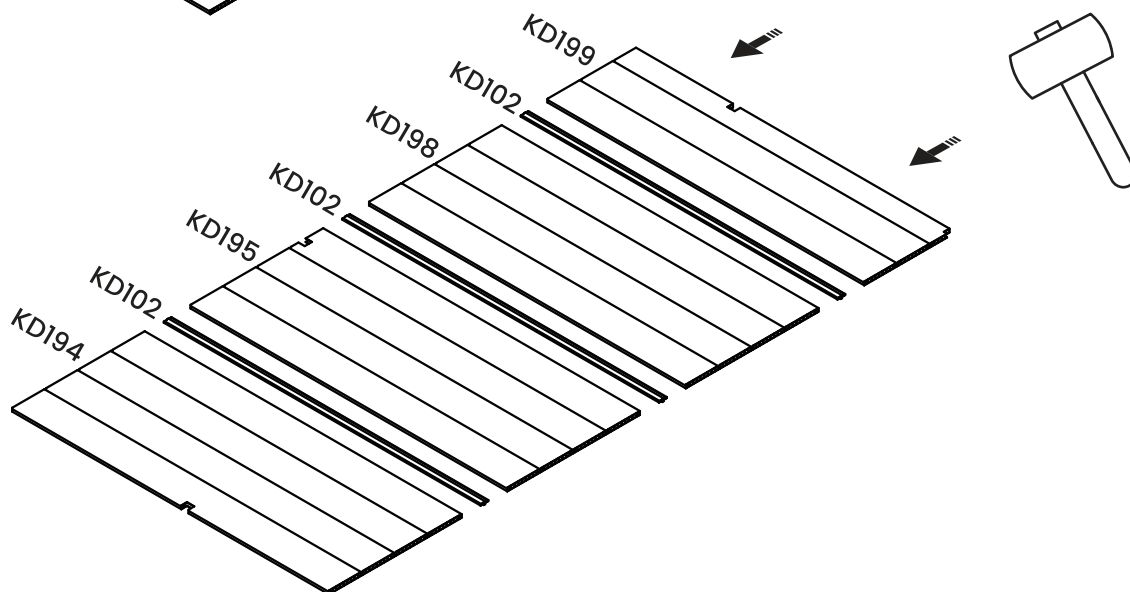
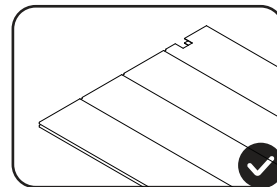
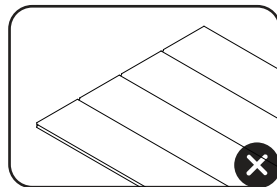
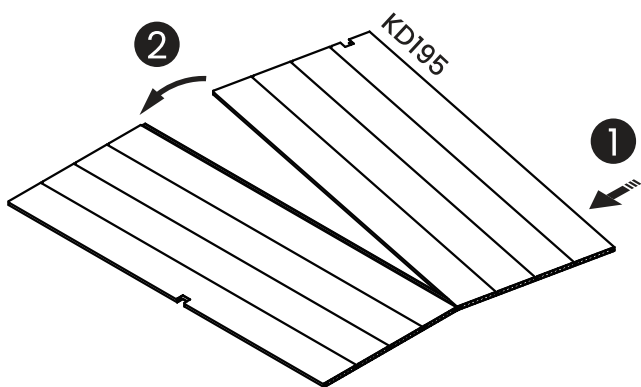
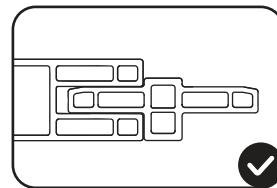
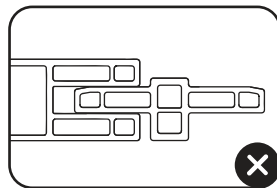
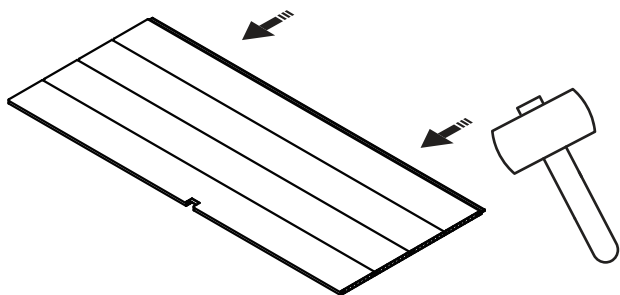
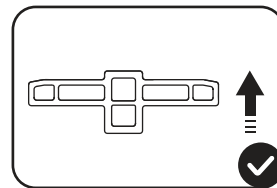
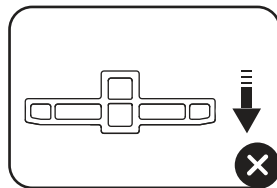
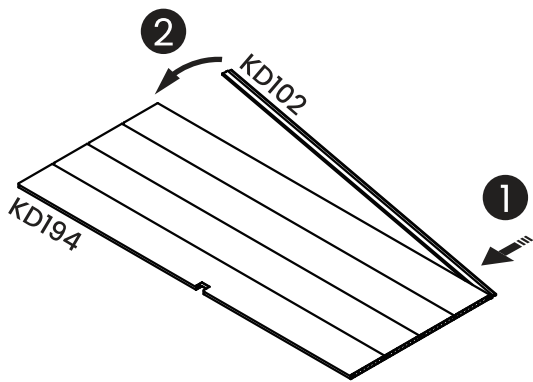



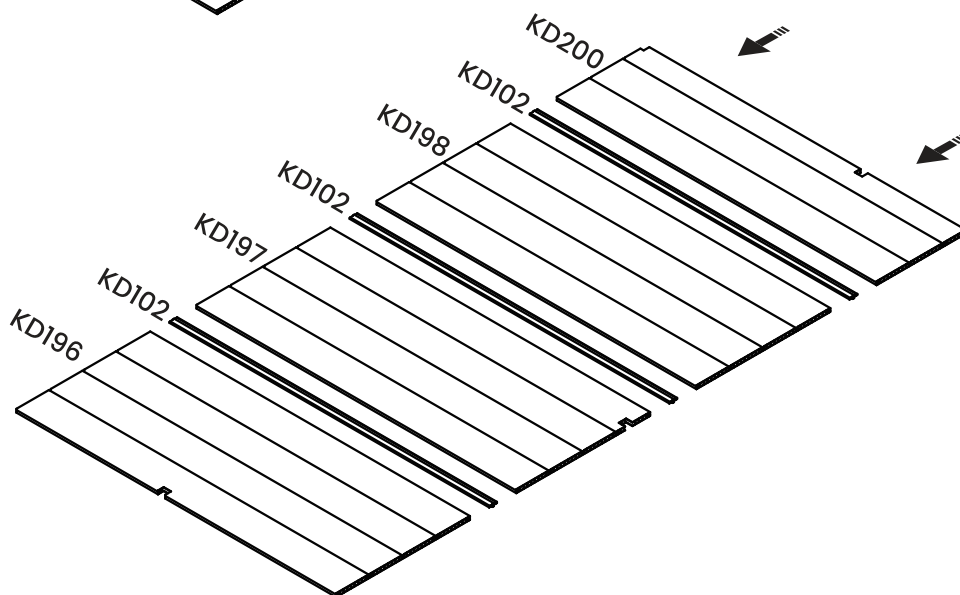
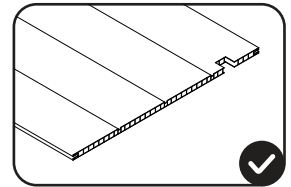
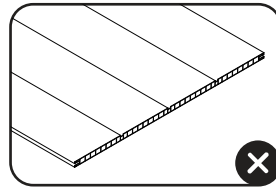
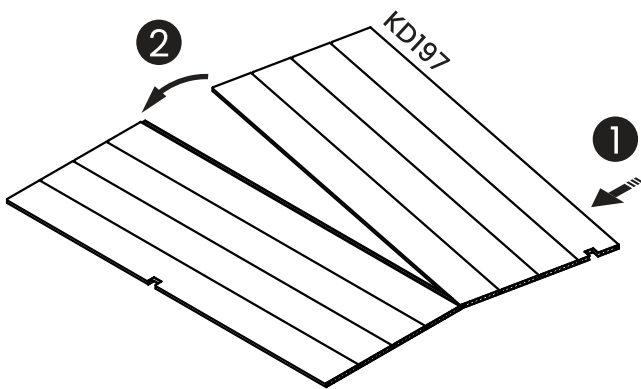
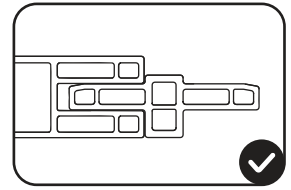
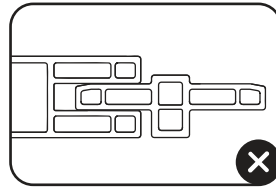
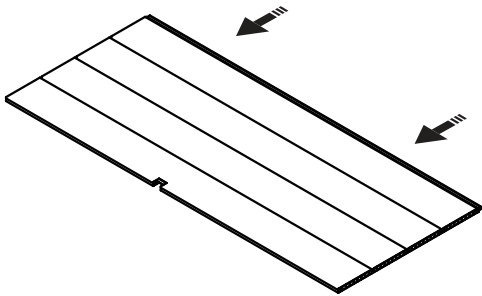
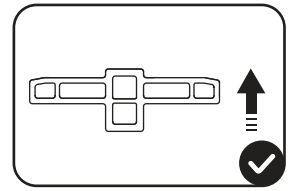
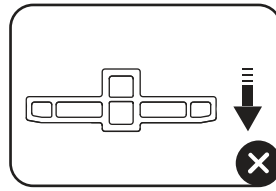
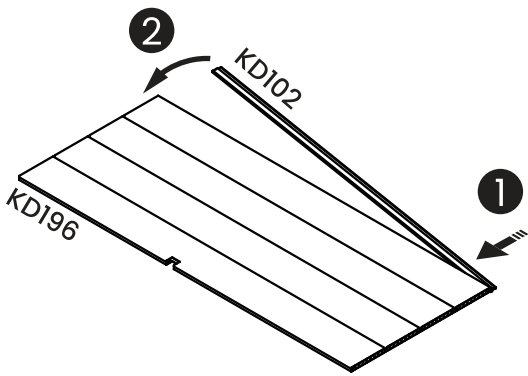

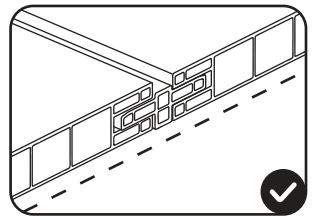
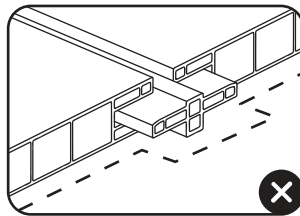
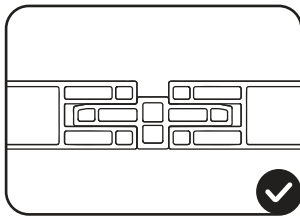
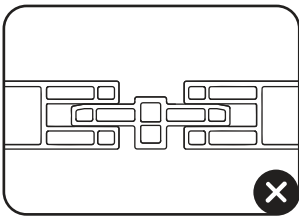
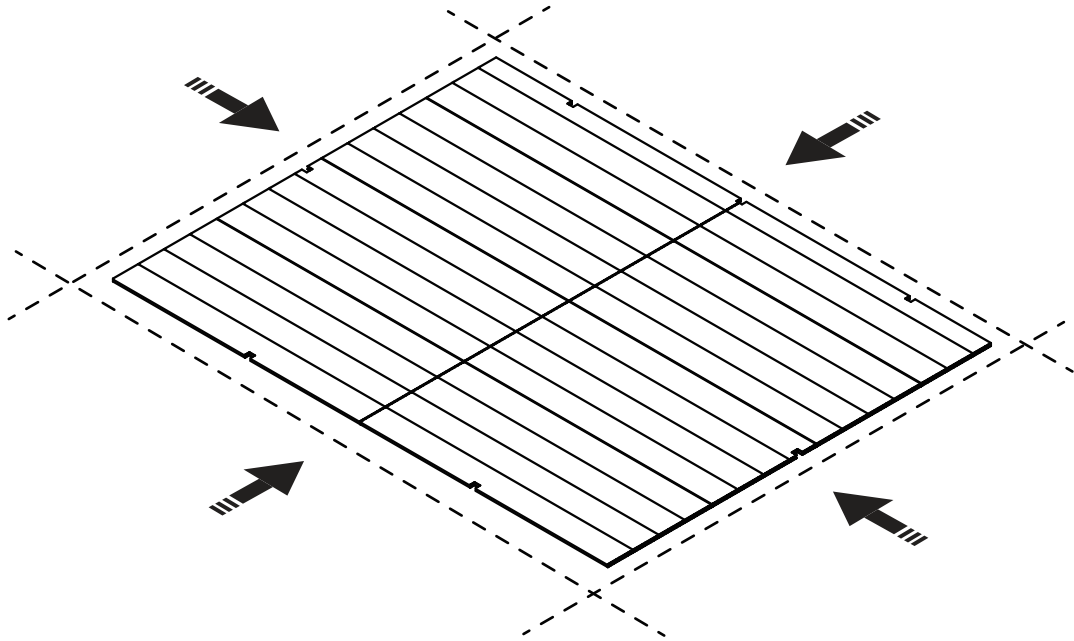

	<p>KD083</p>	<p>x24</p>
---	--------------	------------

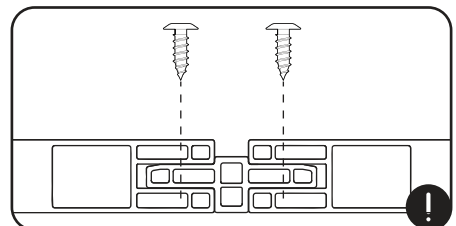
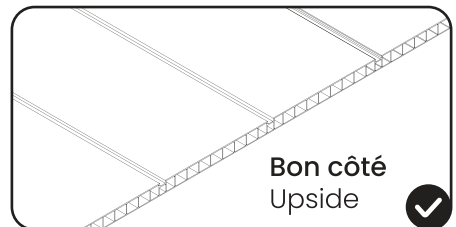
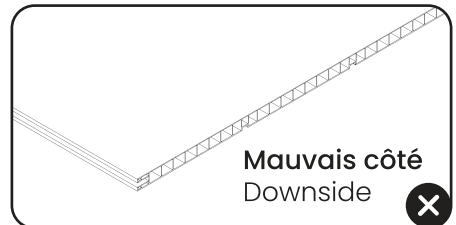
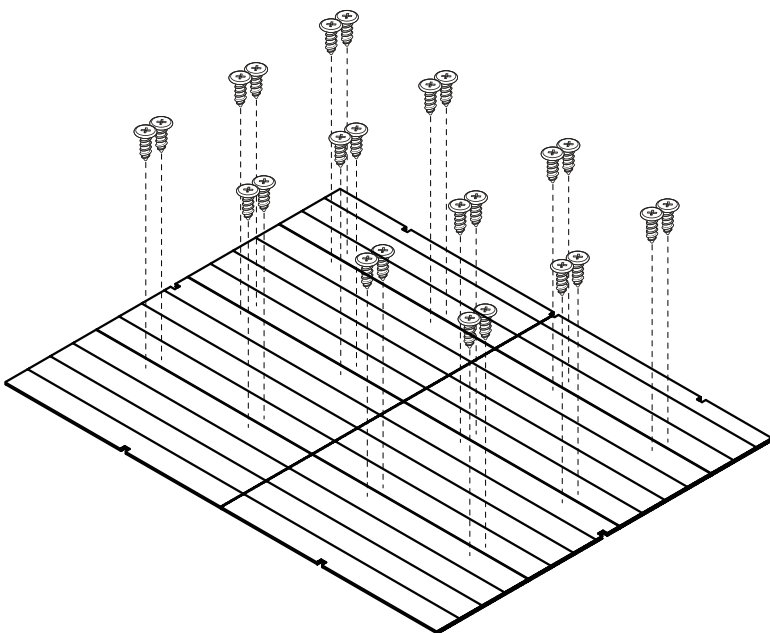

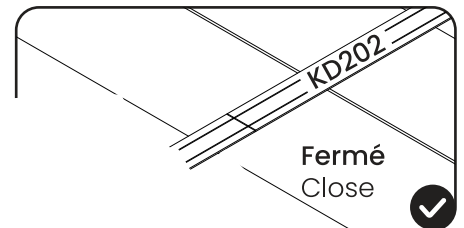
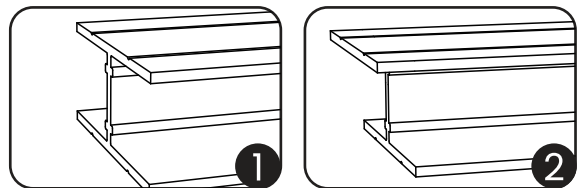
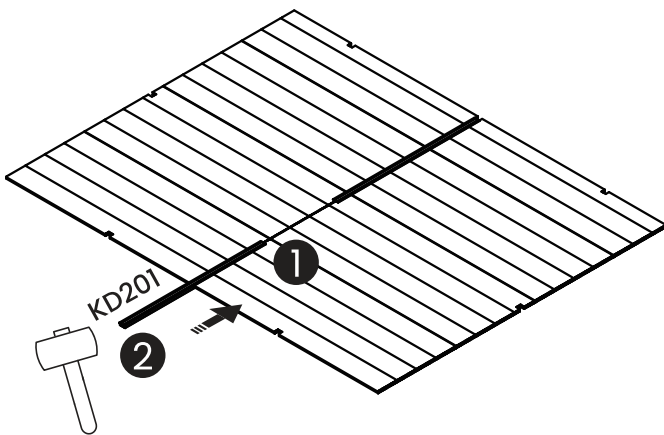
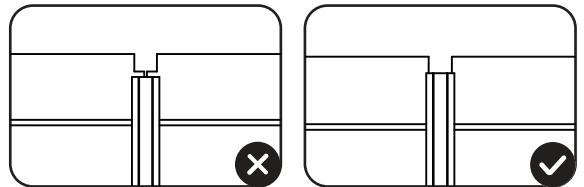
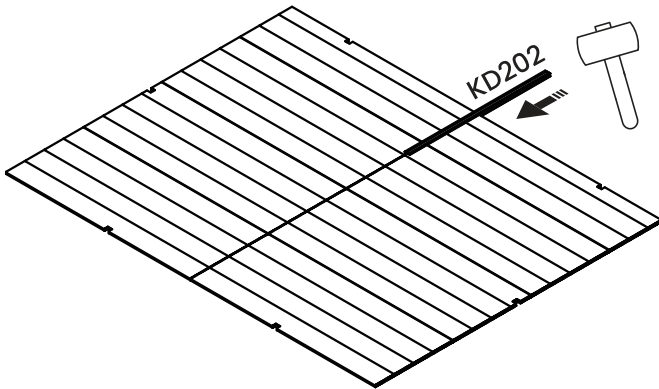
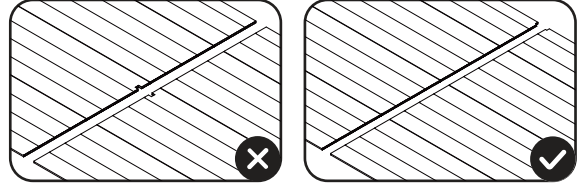
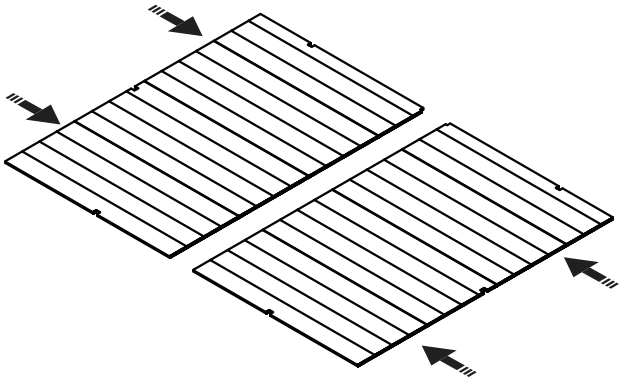

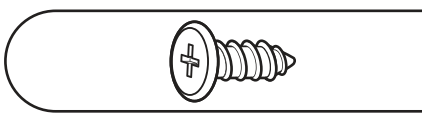
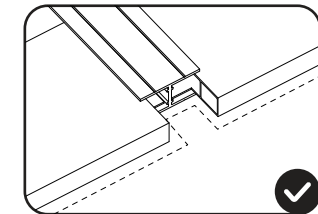
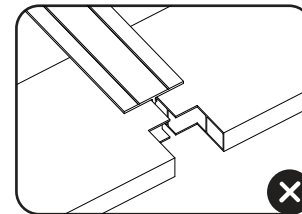
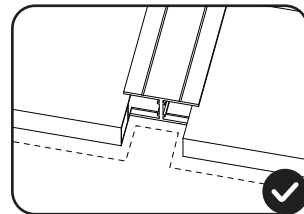
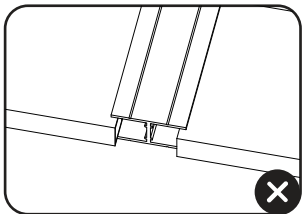
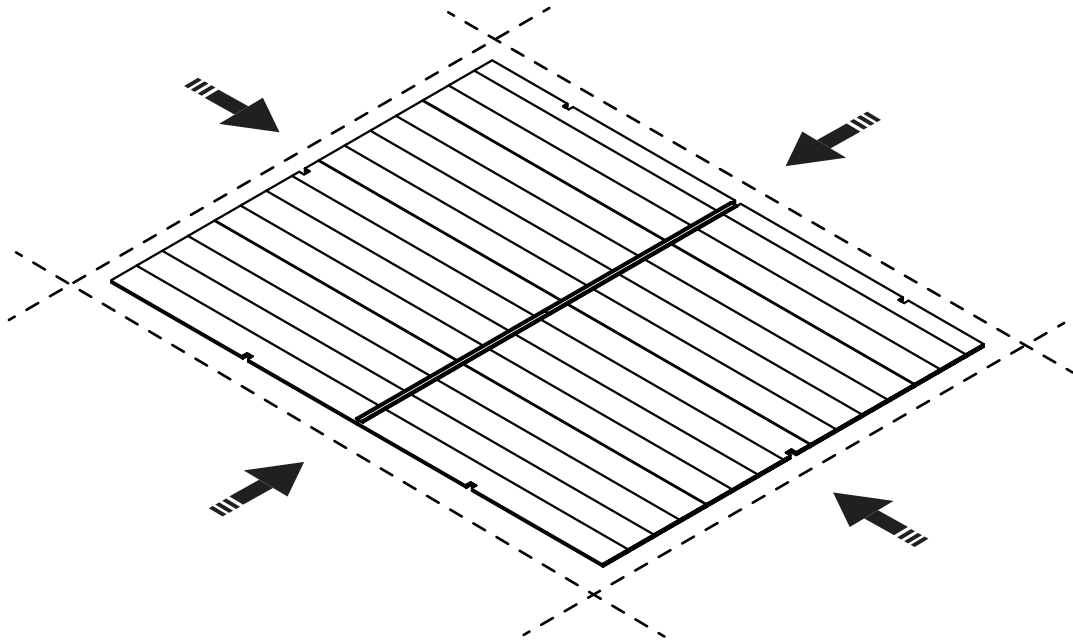

KD083

x16

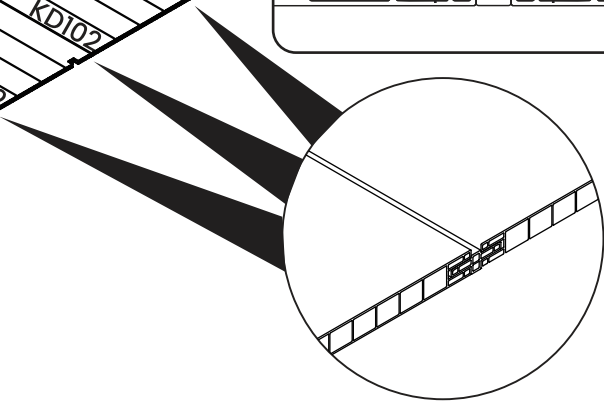
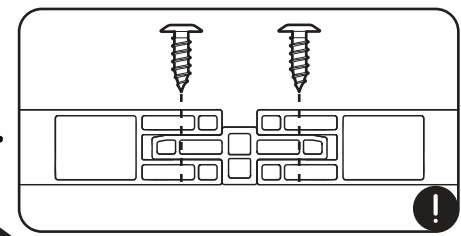
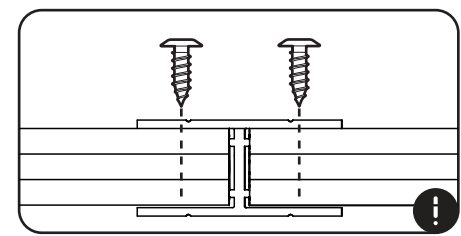
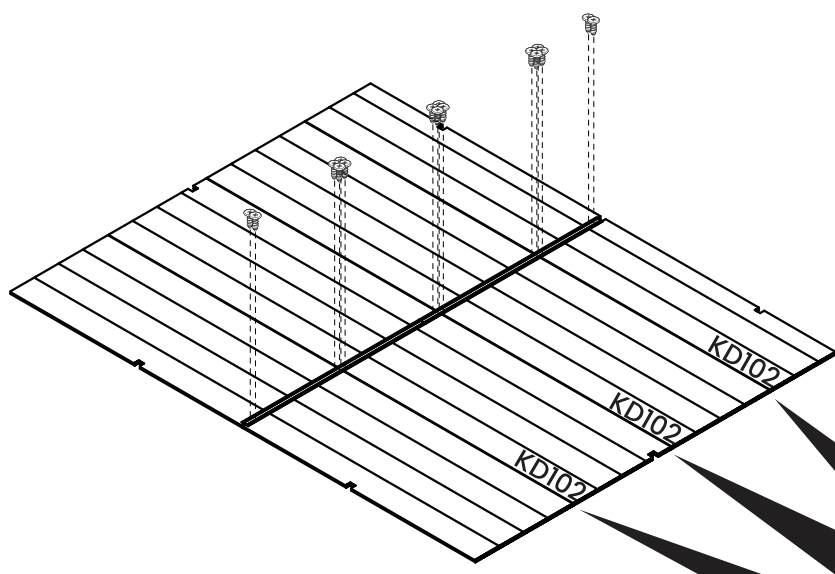

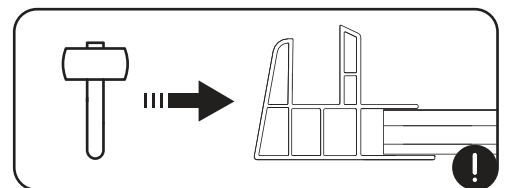
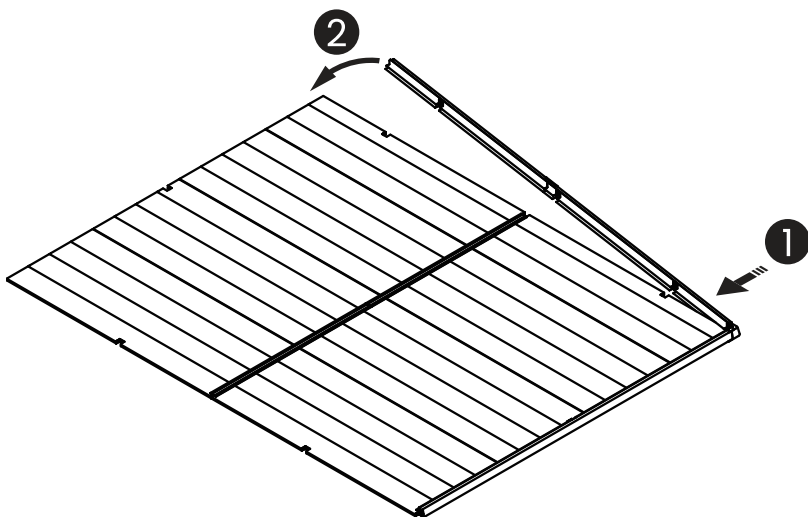
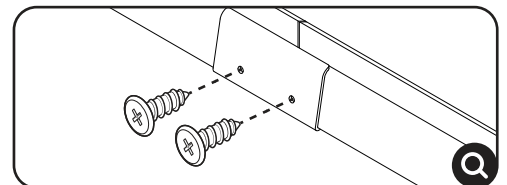
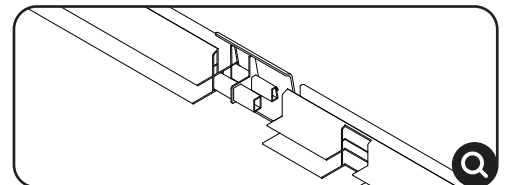
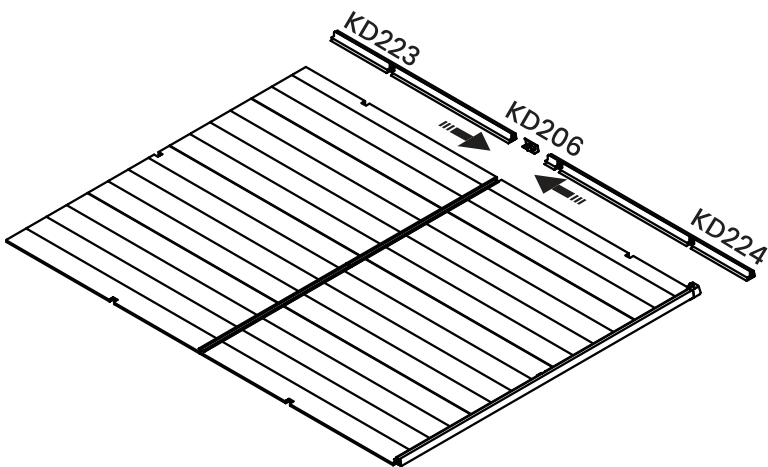
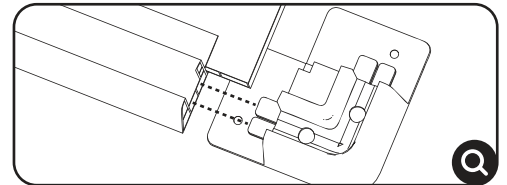
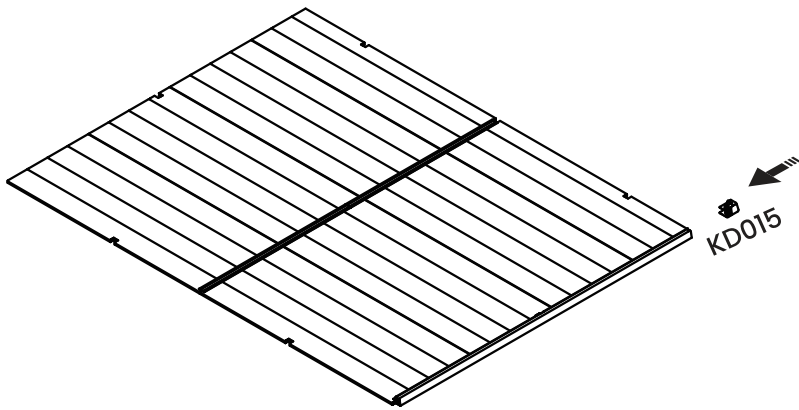
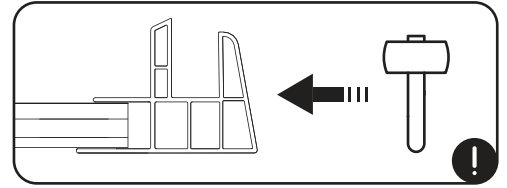
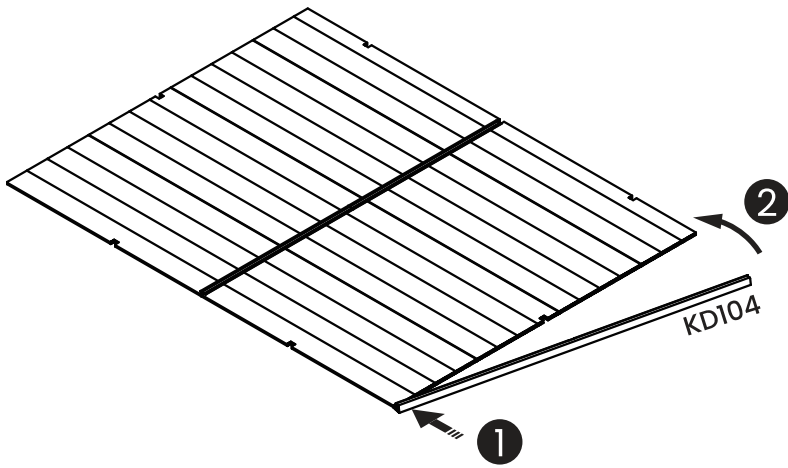

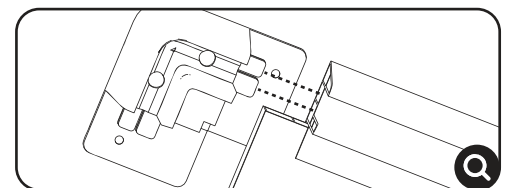
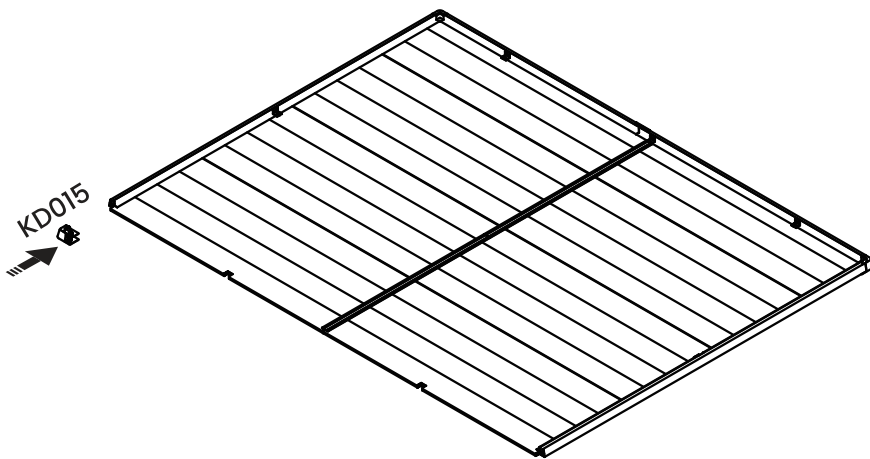
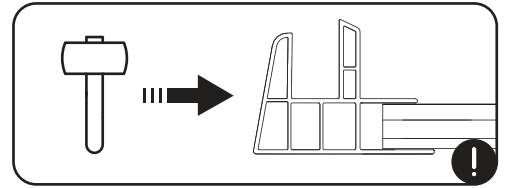
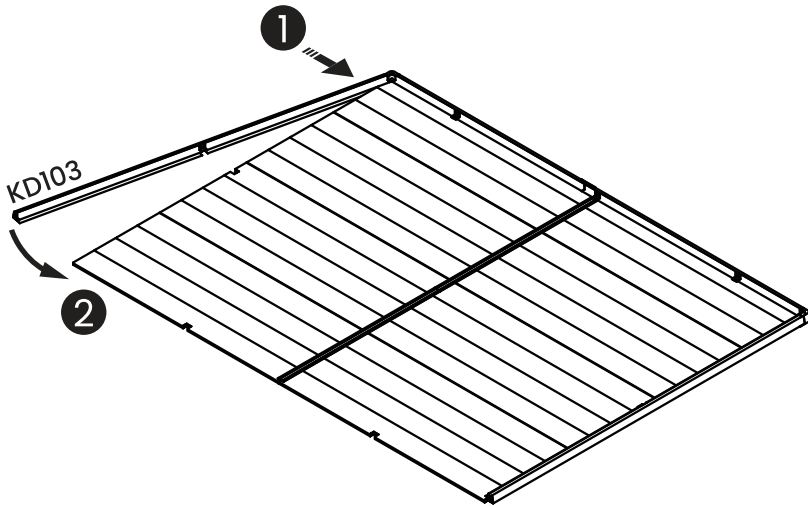
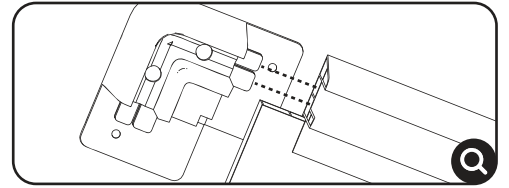
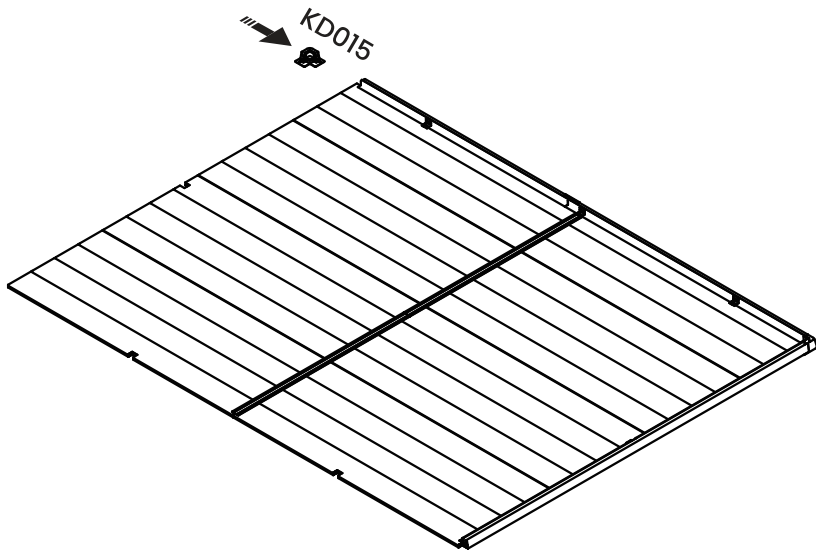

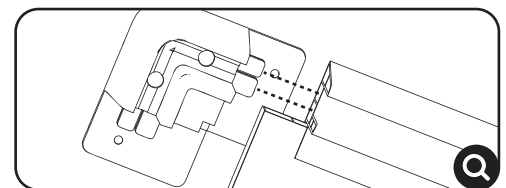
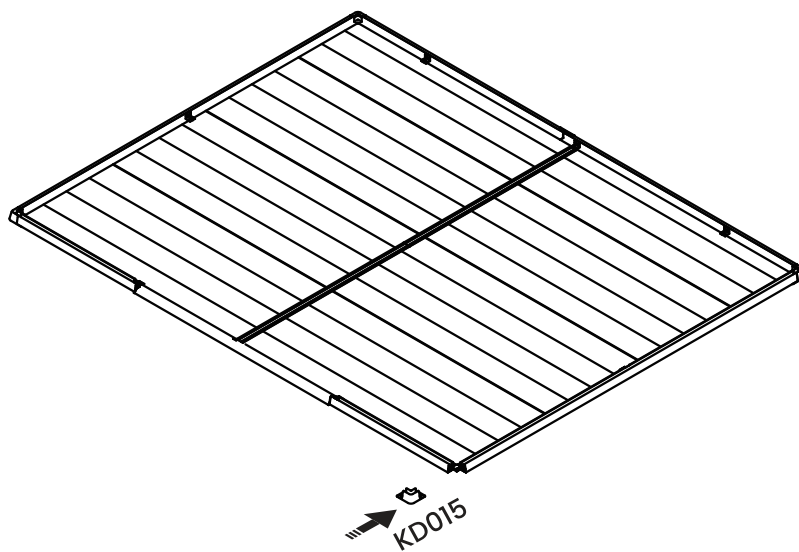
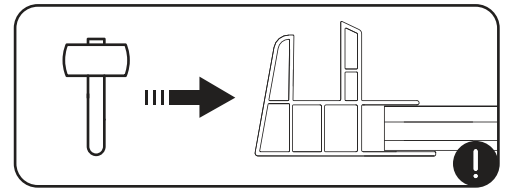
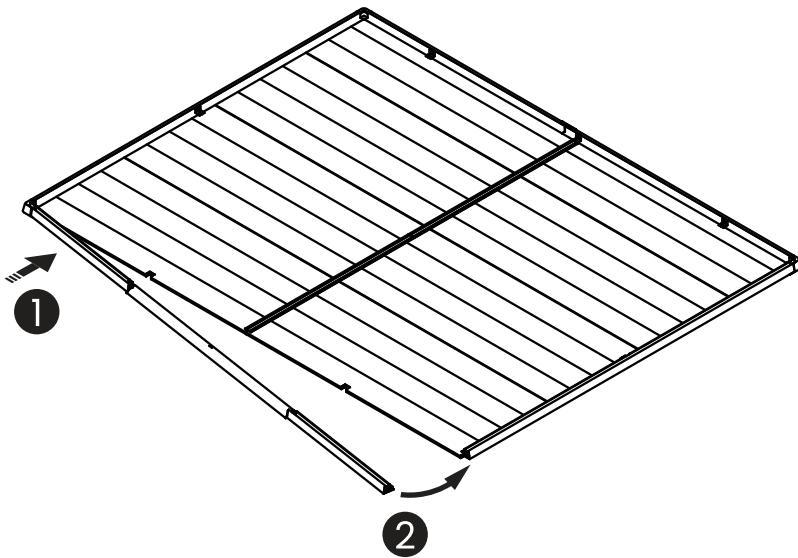
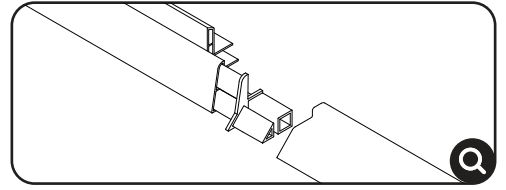
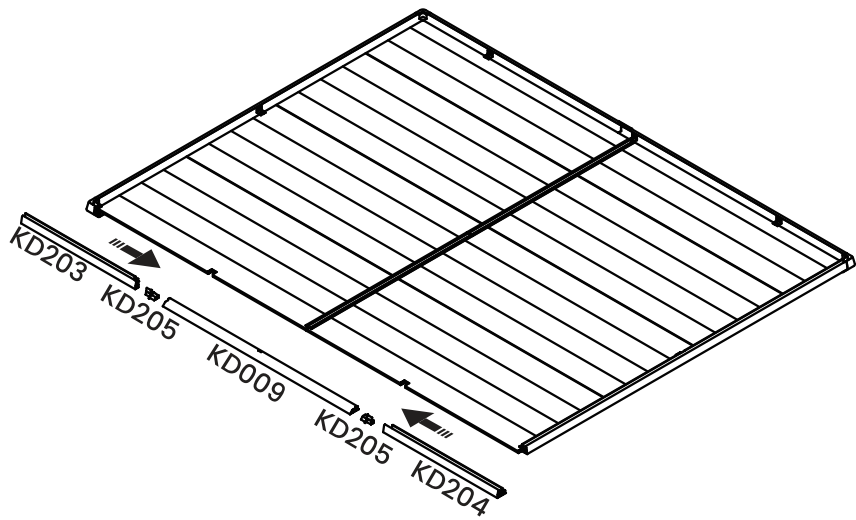



# Vérifier la marge sur une ligne

Check the margin on a line

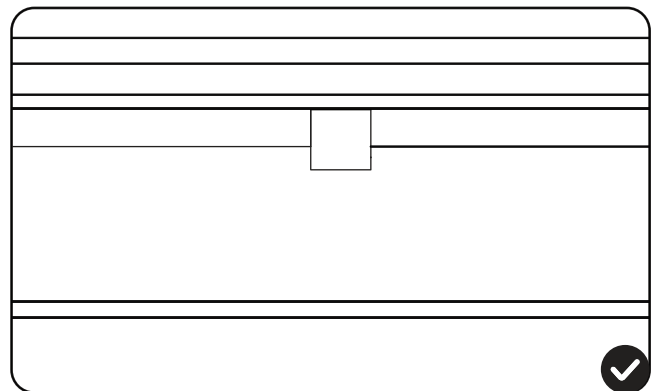
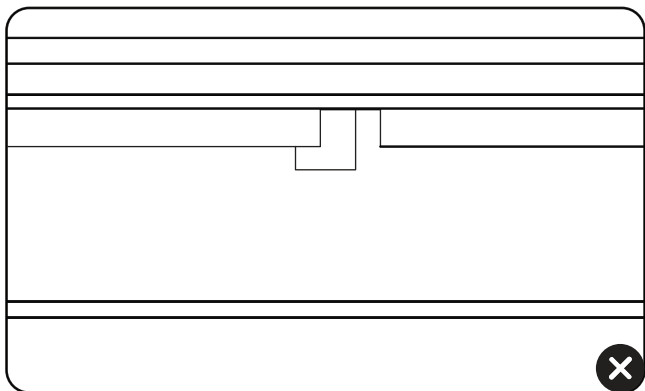
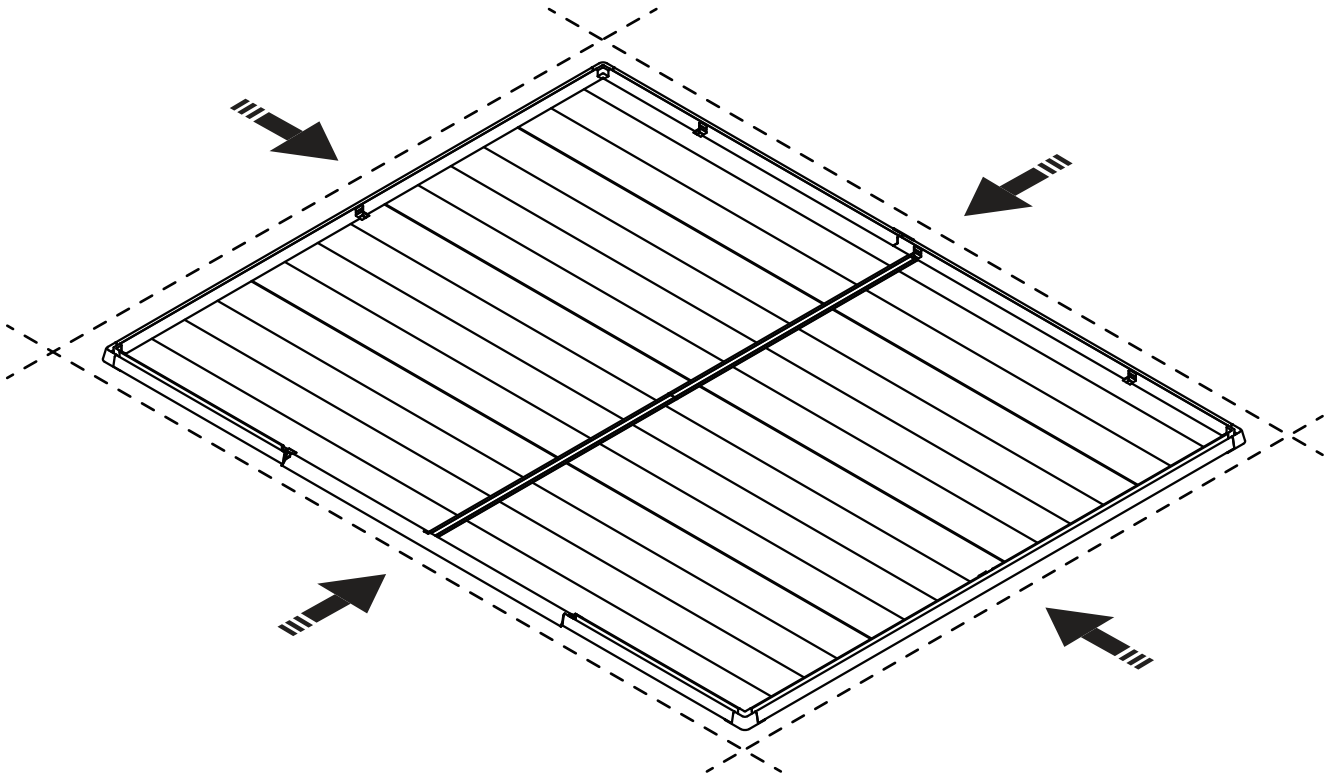



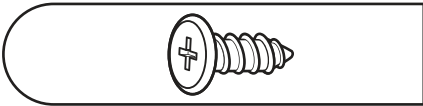

KD083

x29

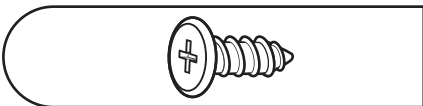
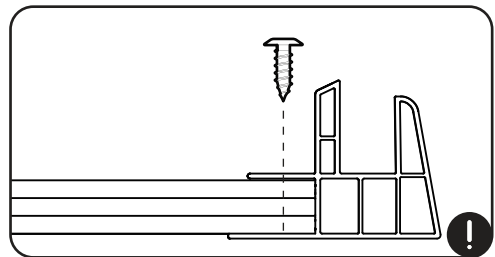
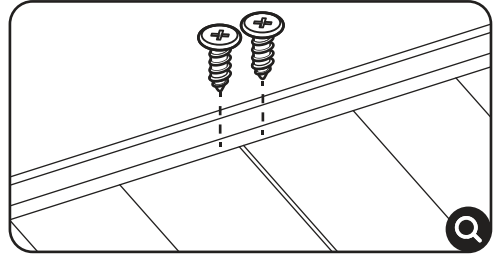
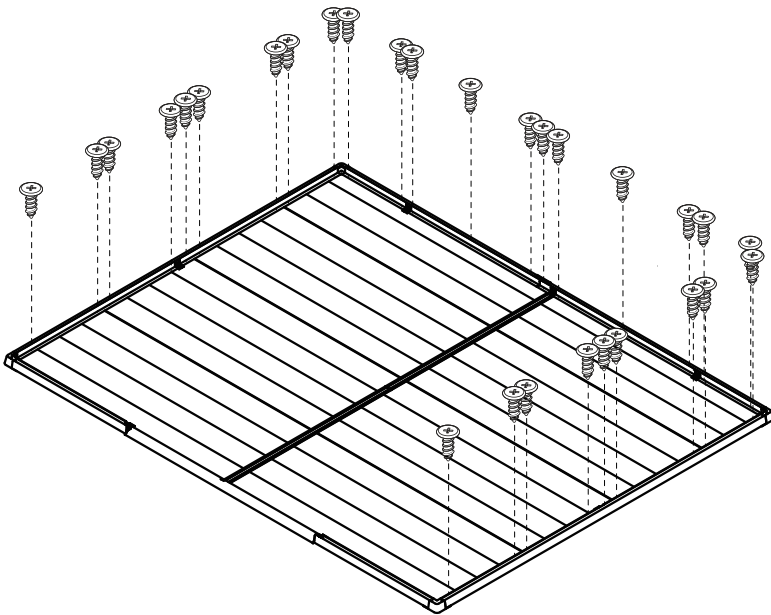

KD083

x14

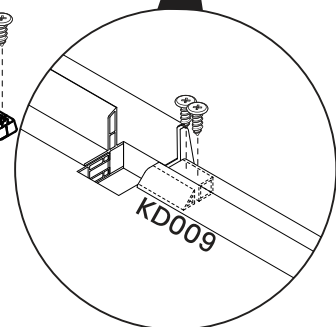
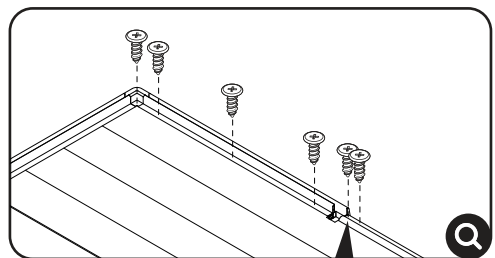
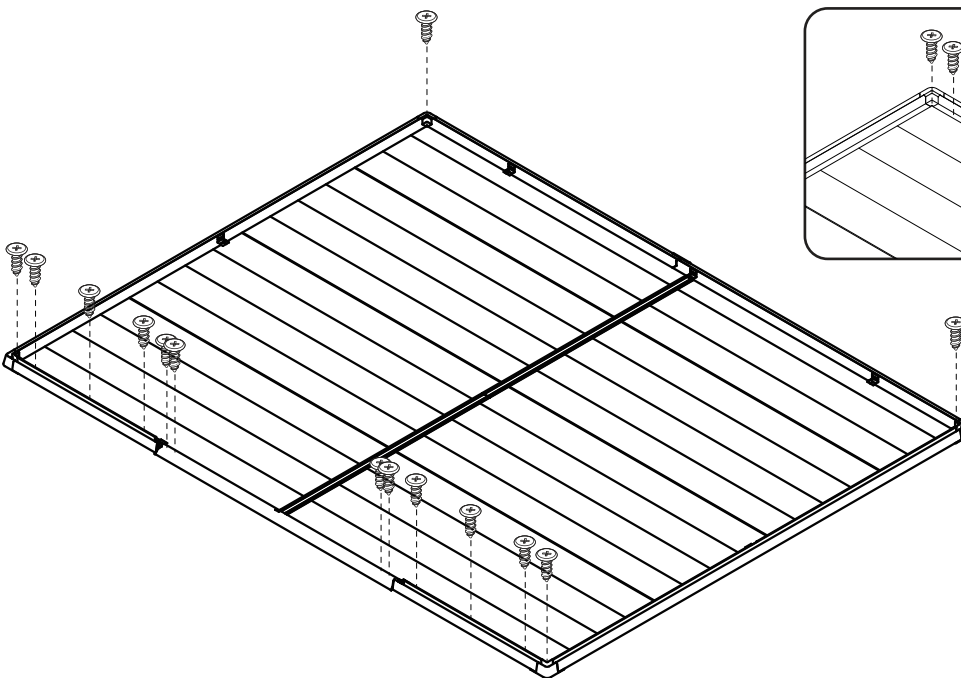



# Assemblage du cadre

## Frame Assembly

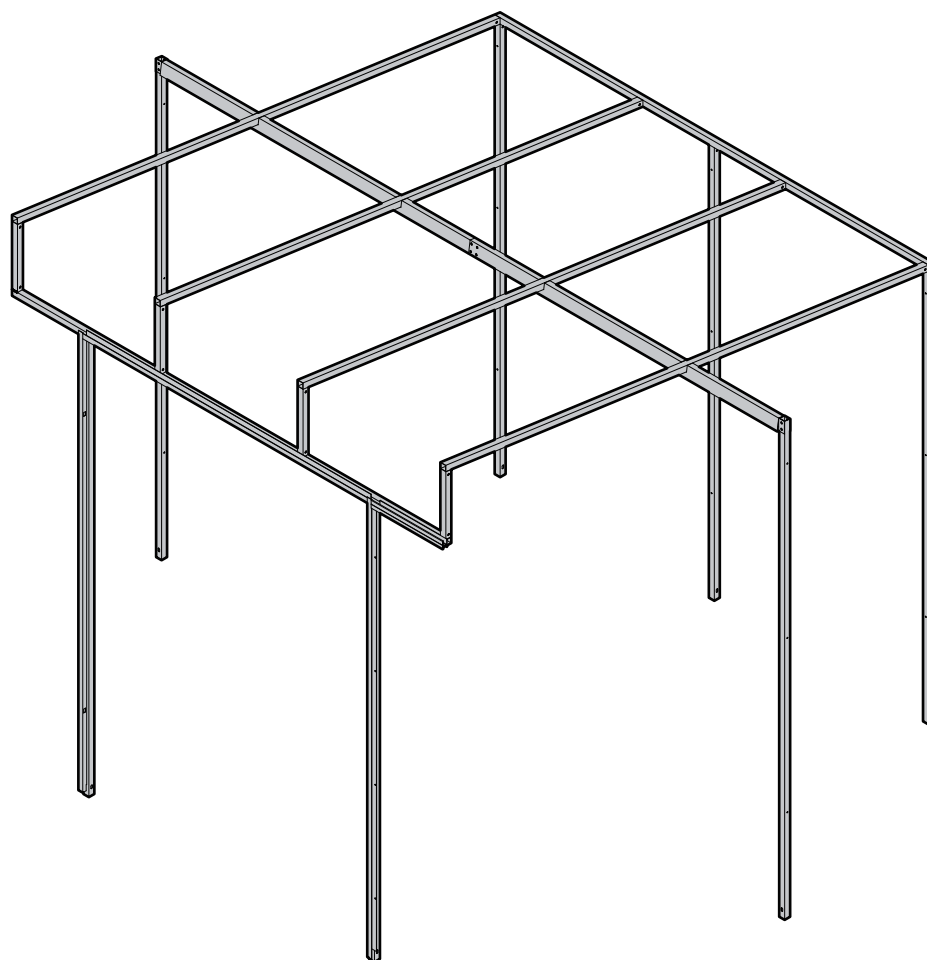

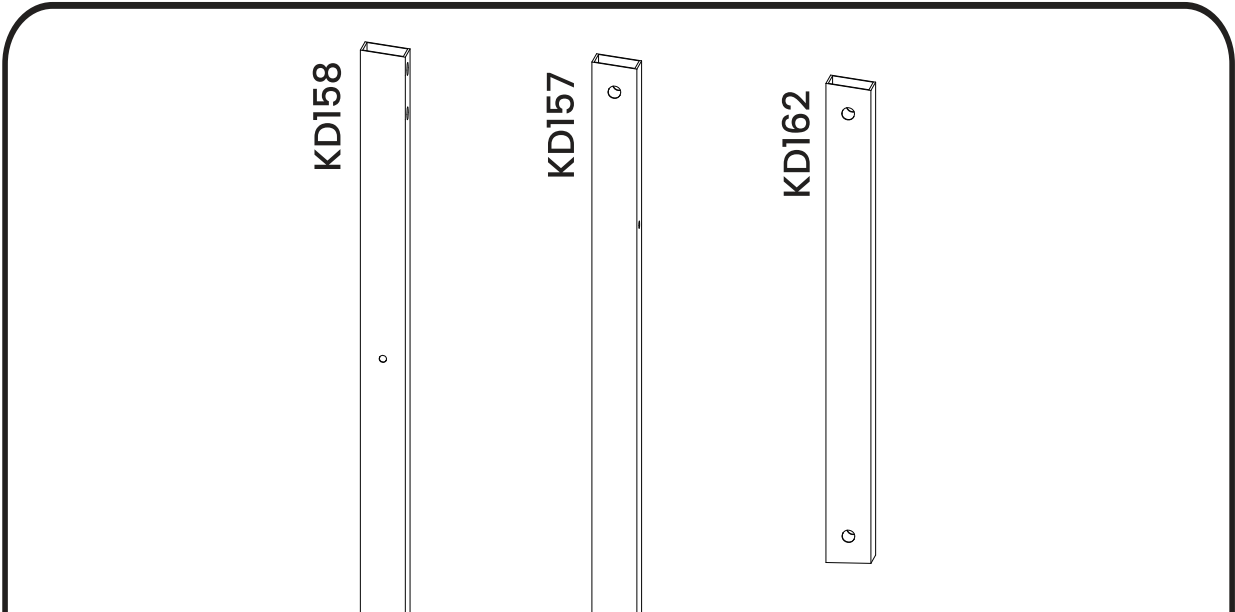

**Veillez noter le sens d'installation. L'extrémité supérieure du tube carré doit être orientée vers le côté « avant ».**

Please note the installation direction.

The higher end of the square tube should face the "front" side.

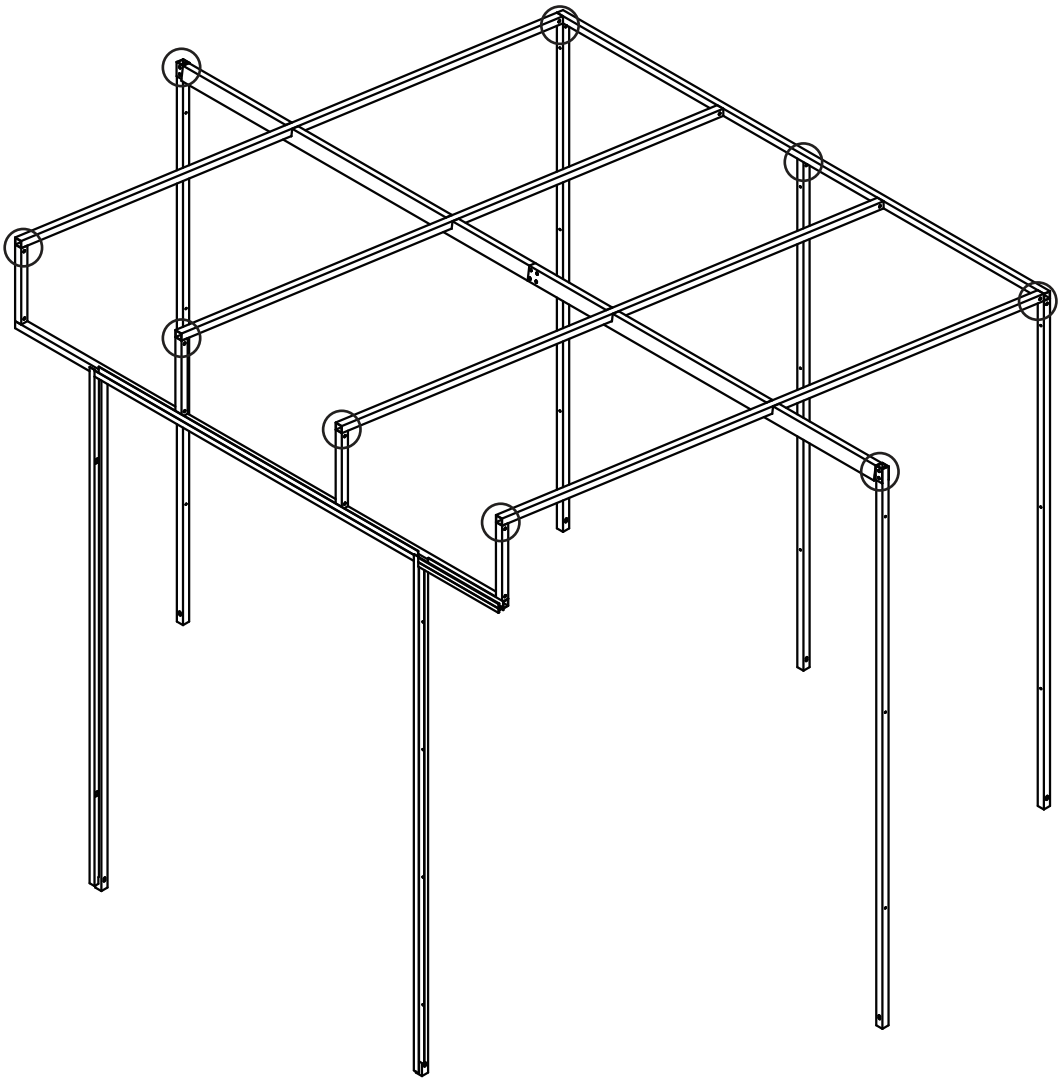

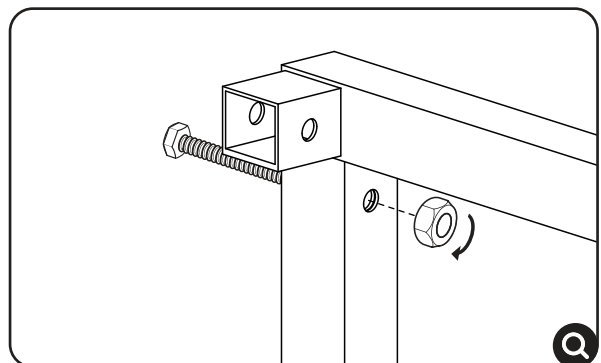
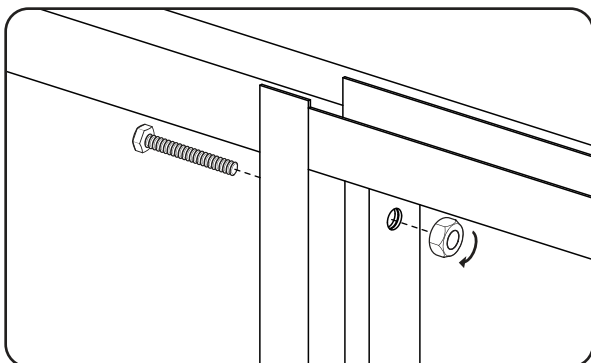
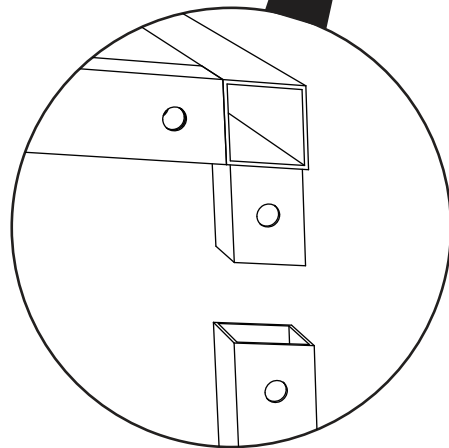
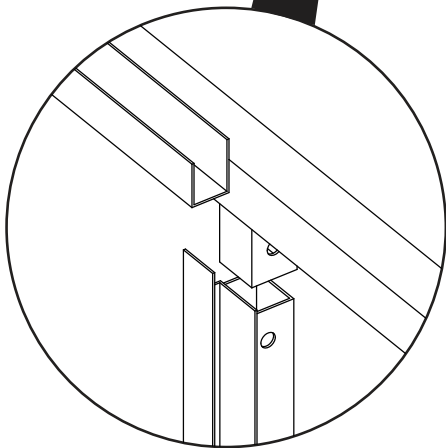
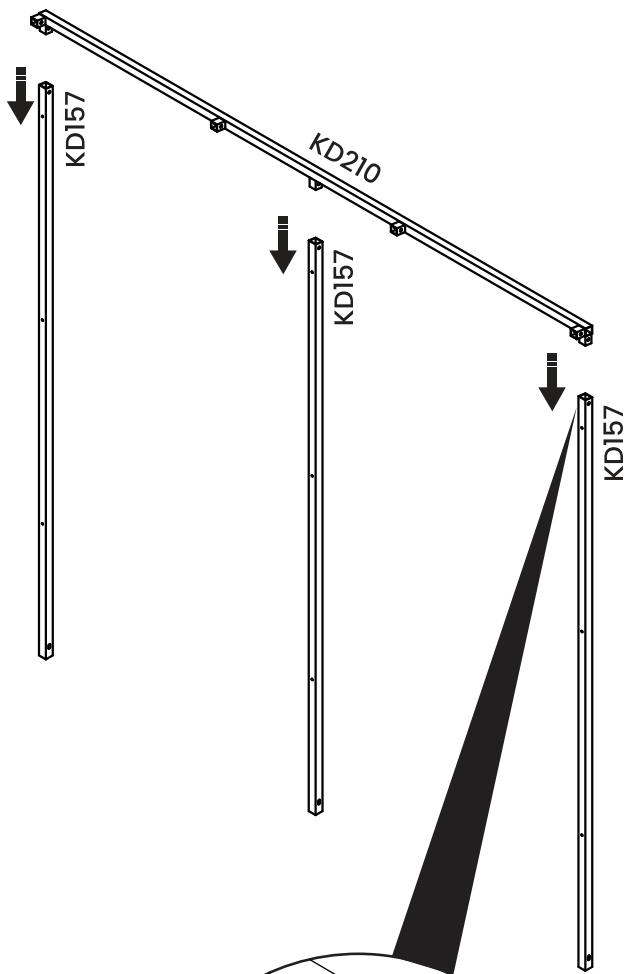
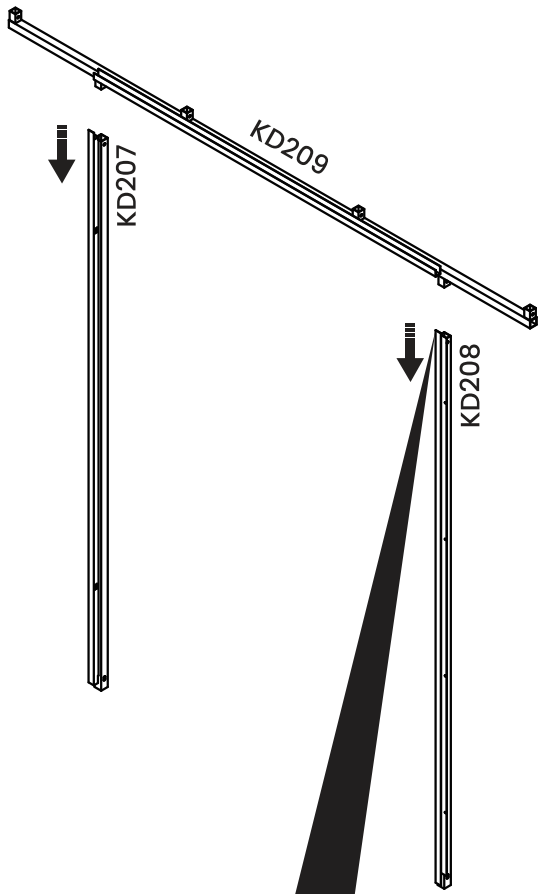
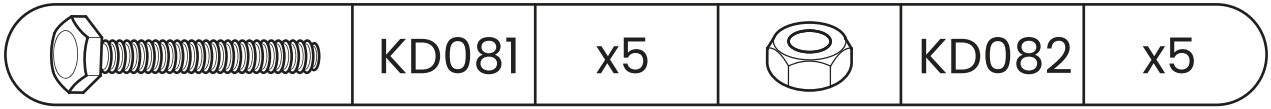

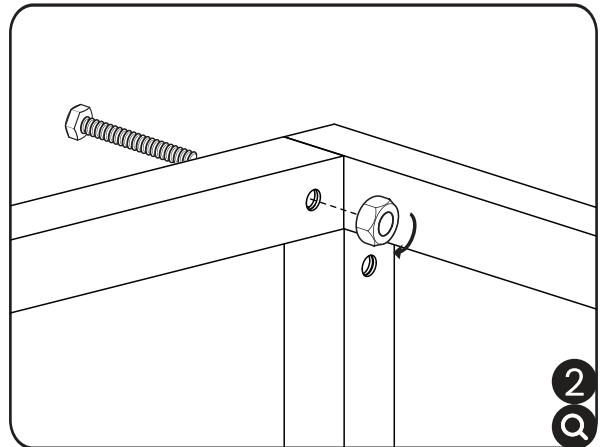
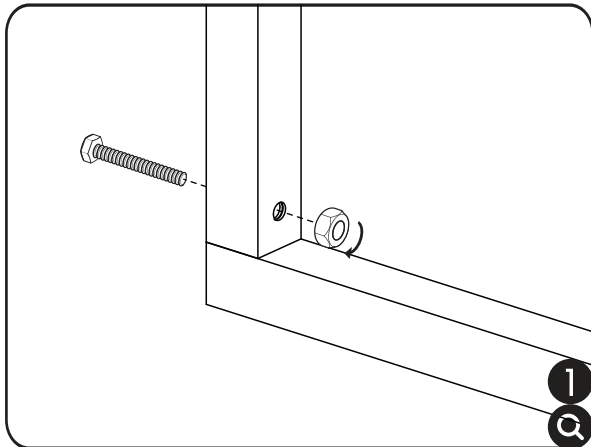
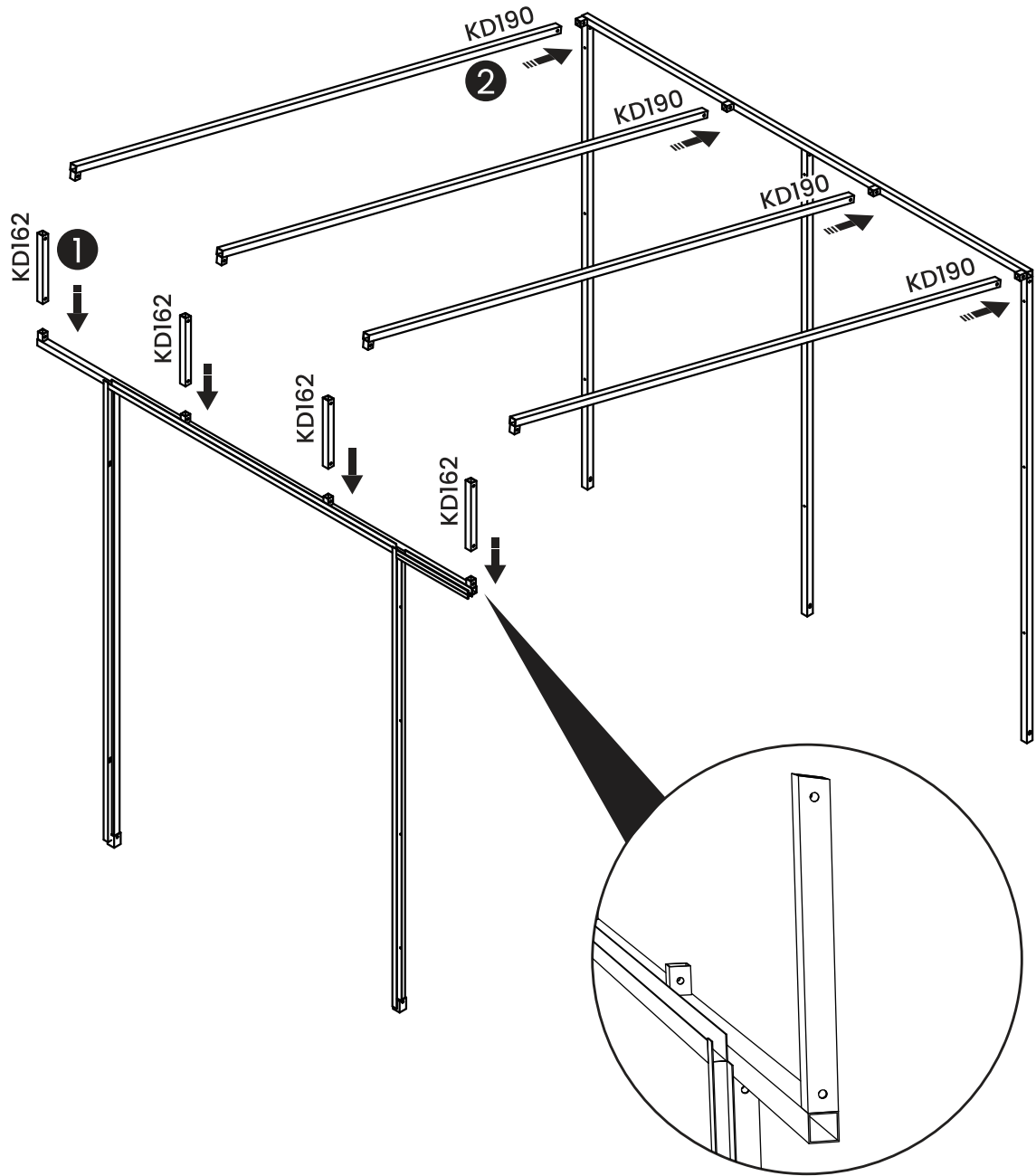

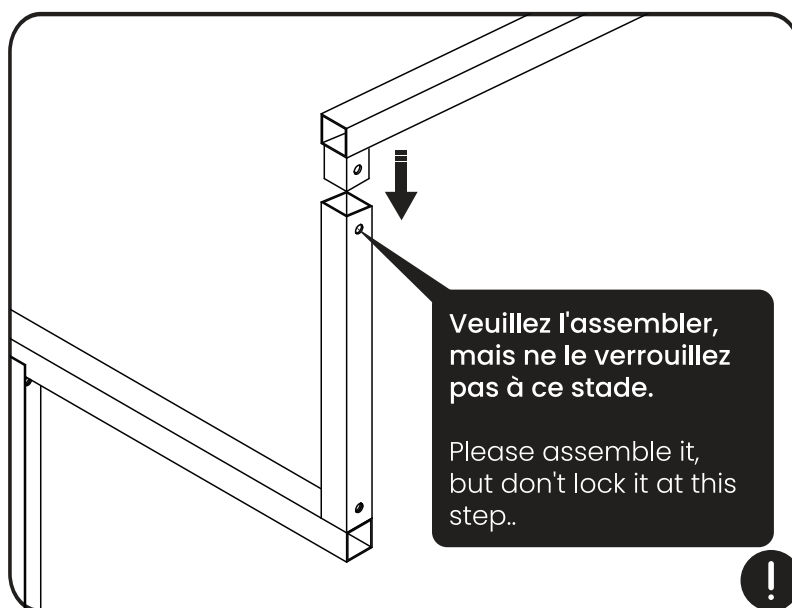
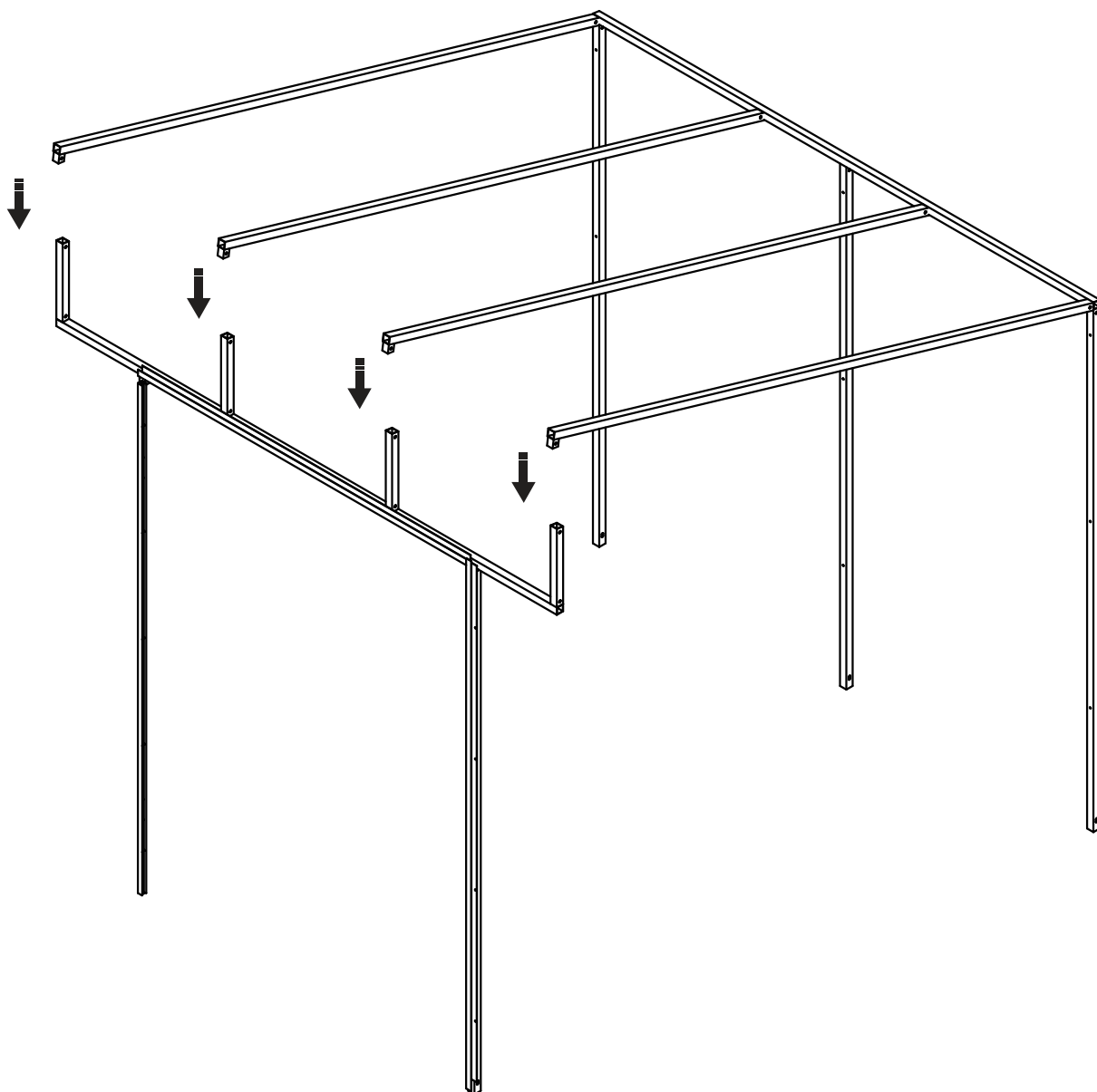

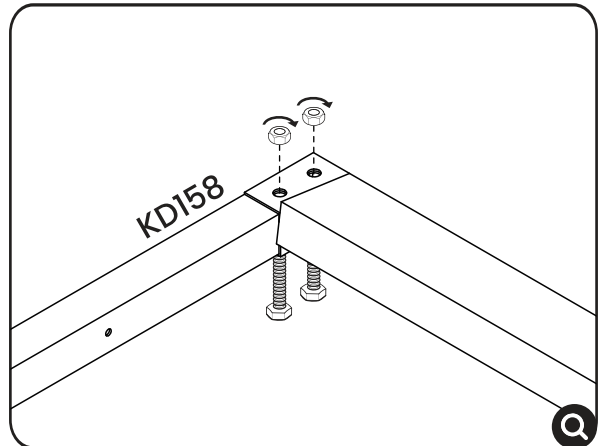
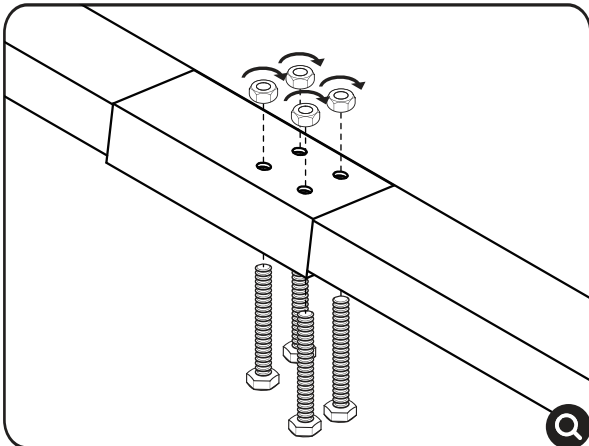
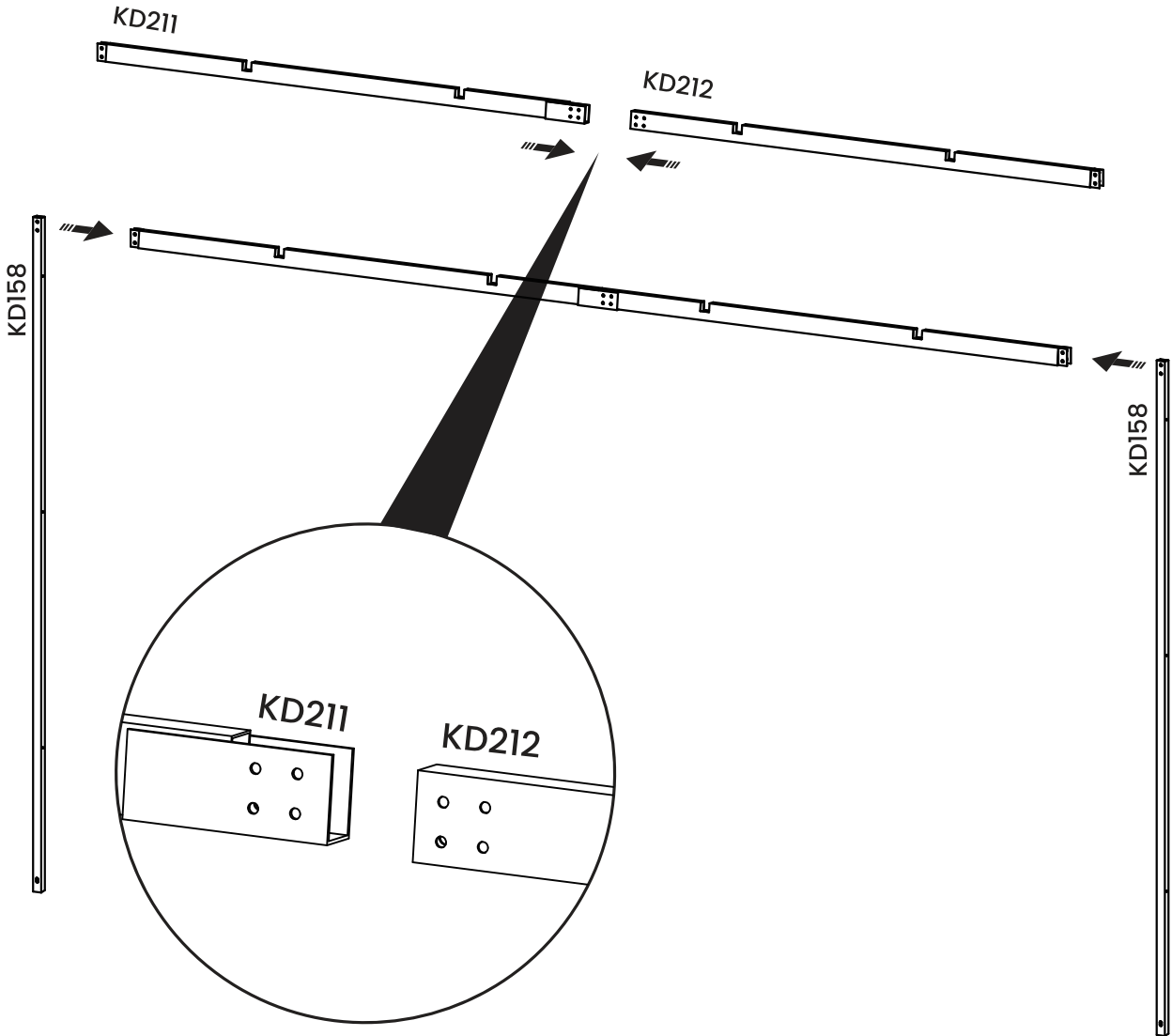



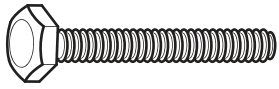

KD081

x4

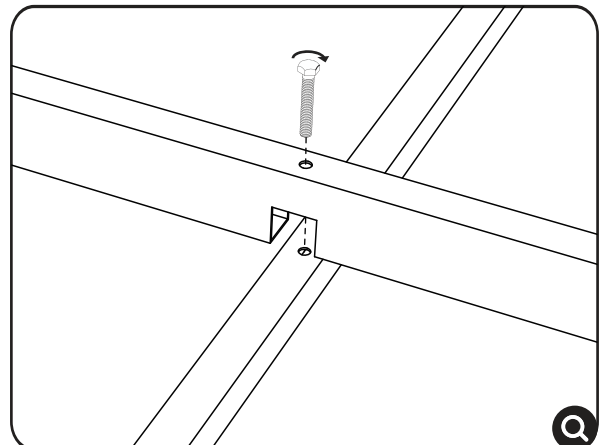
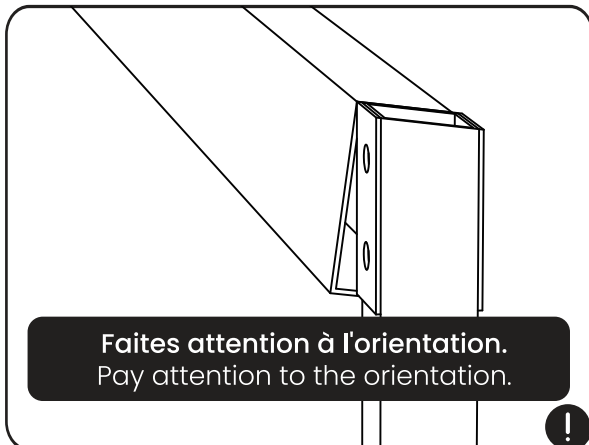
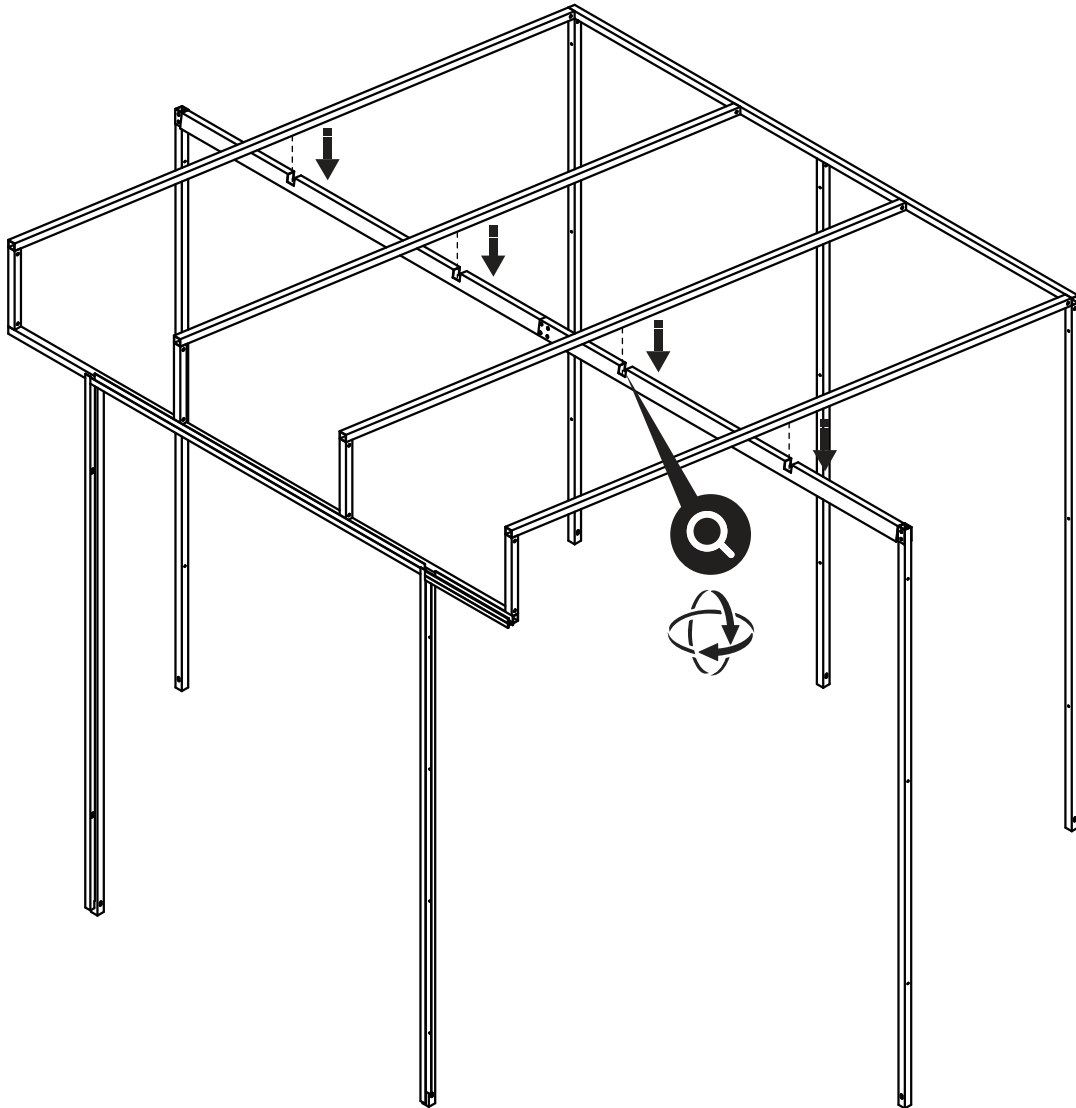

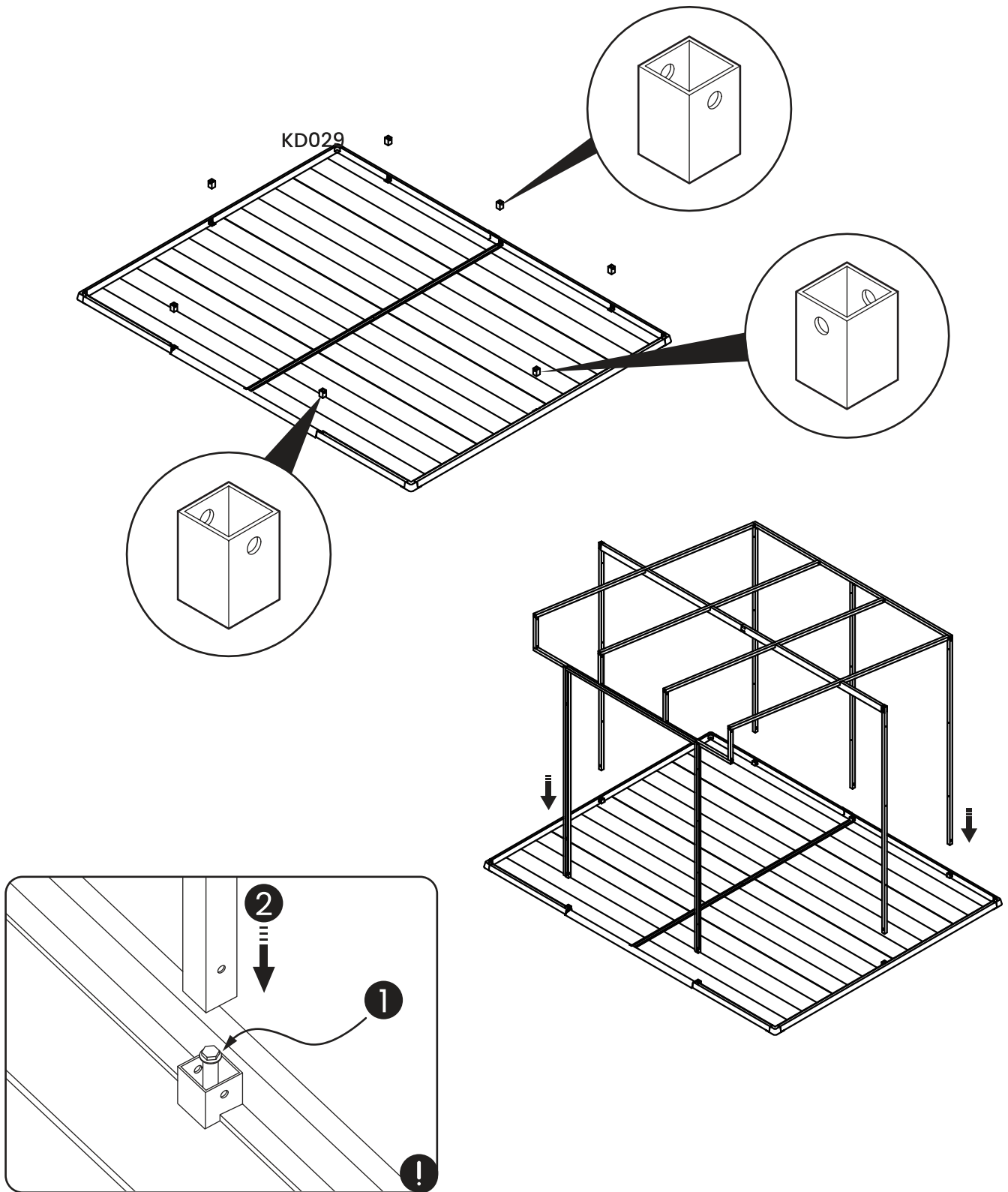

Si vous avez un sol en béton et que vous devez percer des trous pour les vis d'expansion, placez les fixations du cadre (KD029), marquez les positions en fonction des trous, puis utilisez une mèche pour percer les trous.

If you have a concrete floor and need to drill holes for expansion screws, please place the frame fixings (KD029), mark the positions according to the holes, and then use a drill bit to drill holes.

## Option A

Plancher en bois / Wooden Floor

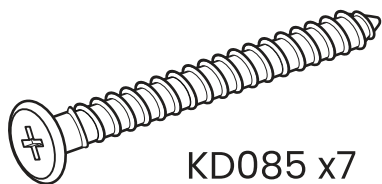

Retirer l'entretoise.  
Take off the spacer.

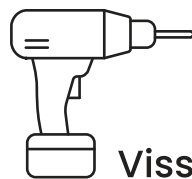
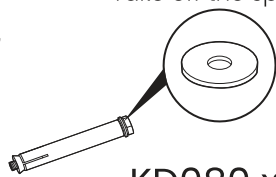

Visseuse  
Screwdriver

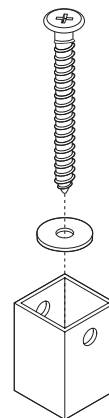

## Option B

Plancher en béton / Concrete Floor

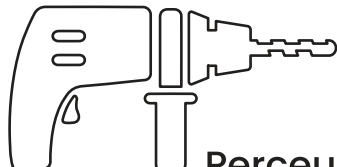
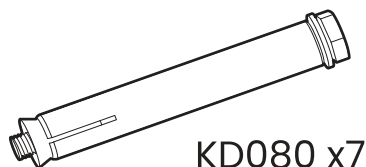

Perceuse  
Drill

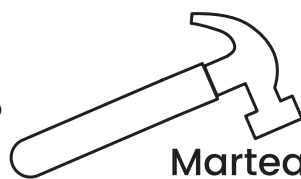

Marteau  
Hammer

Après avoir placé les fixations du cadre au niveau des ouvertures du sol, utilisez une perceuse pour percer les trous en fonction de leur position.

After placing the frame fixings at the floor openings, use a drill bit to make holes according to the hole positions.

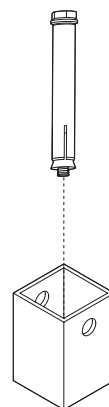

## Option C

Sol / Soil Ground

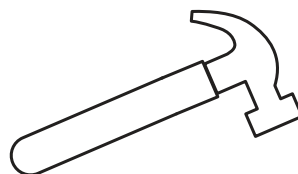
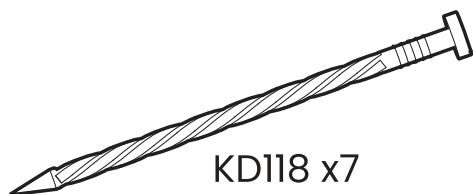

Marteau  
Hammer

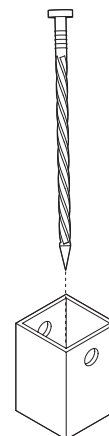

**Veillez utiliser un outil approprié pour enfoncer le KD080 ou le KD118, mais nous avons également offert un KD080 supplémentaire pour ce faire.**

Please use an appropriate tool to drive in the KD080 or the KD118, however we also offered an extra KD080 to do that.

**Que vous choisissiez l'option A, B ou C, ne verrouillez pas le KD029 à ce stade !**  
Whether you select option A, B, or C, please do not lock KD029 at this step!



# Assemblage des murs

## Wall Assembly

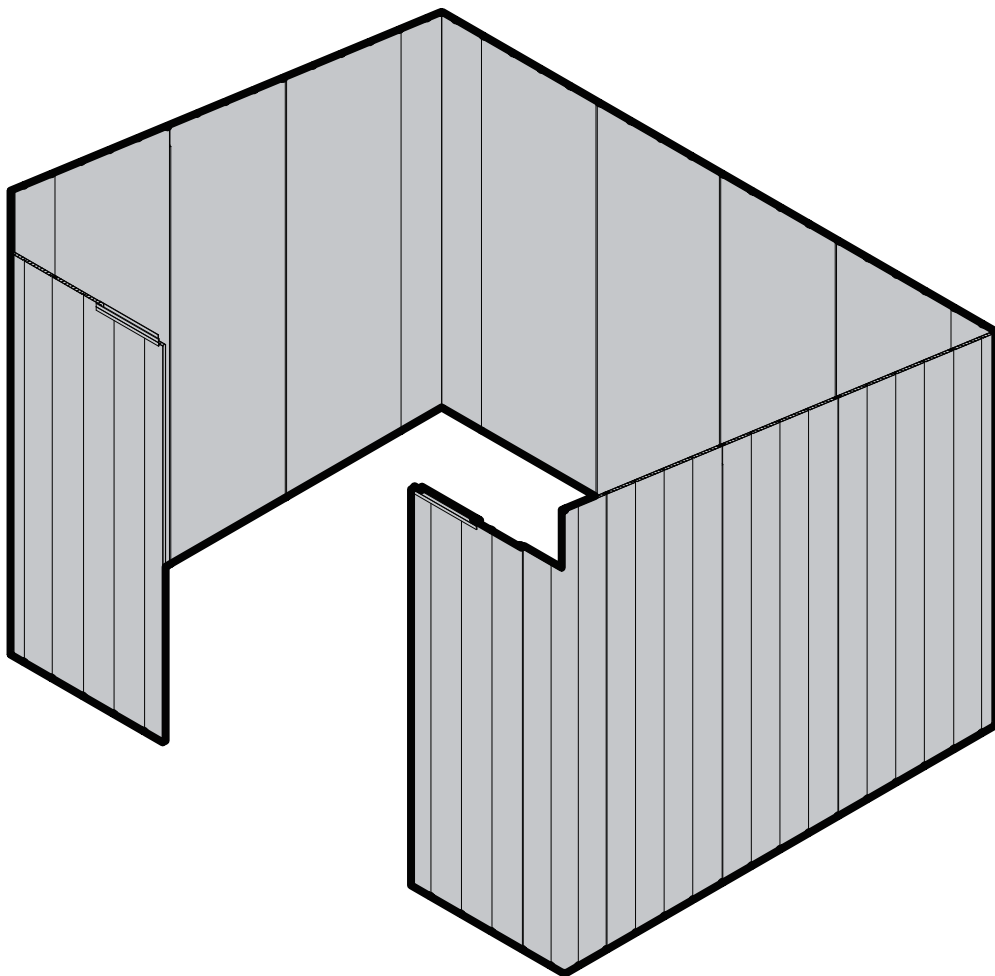

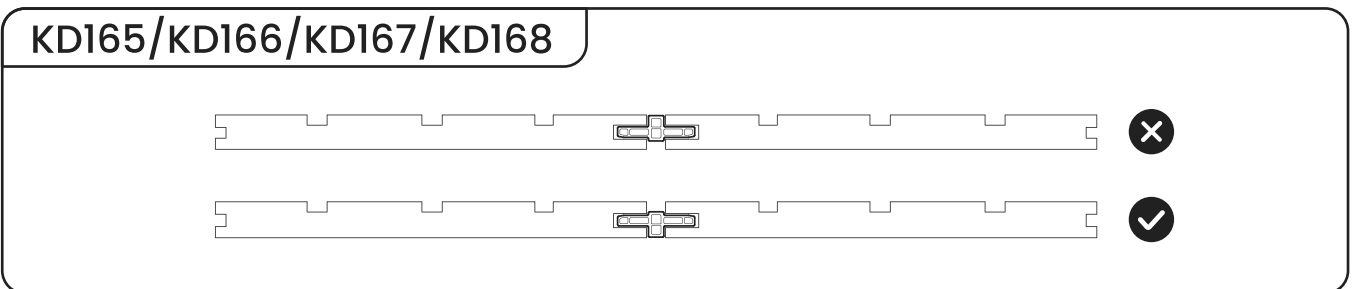
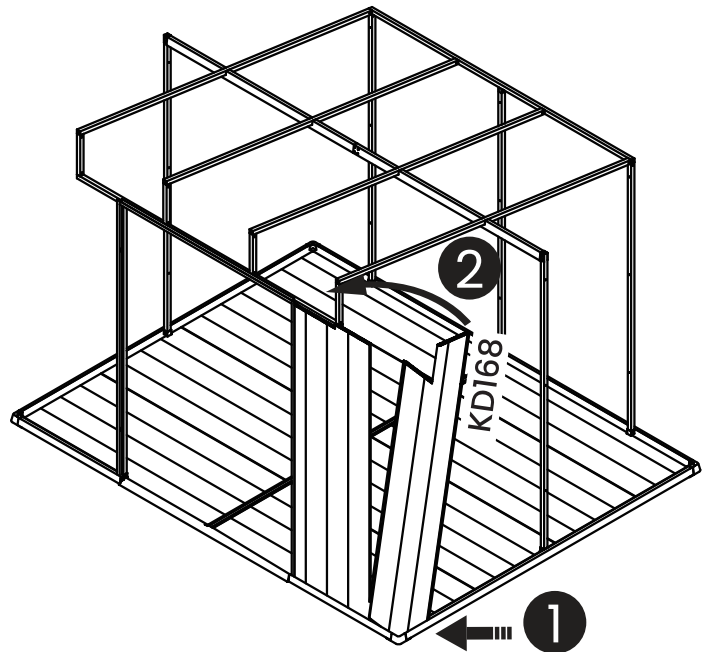
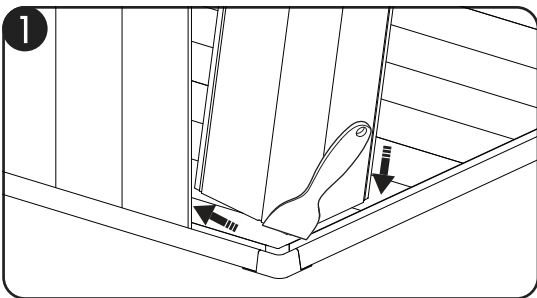
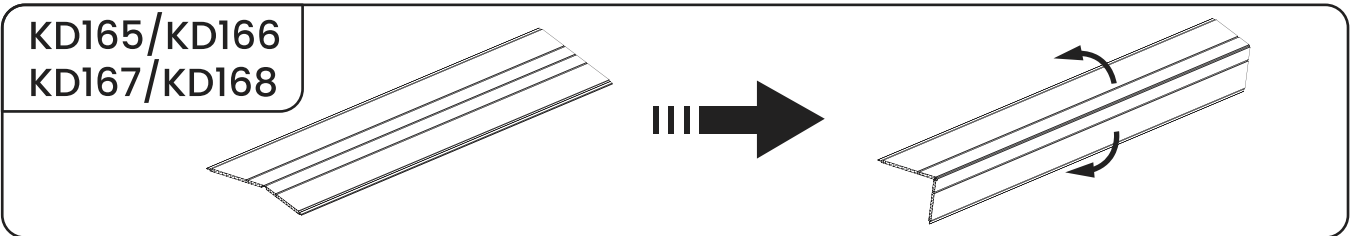
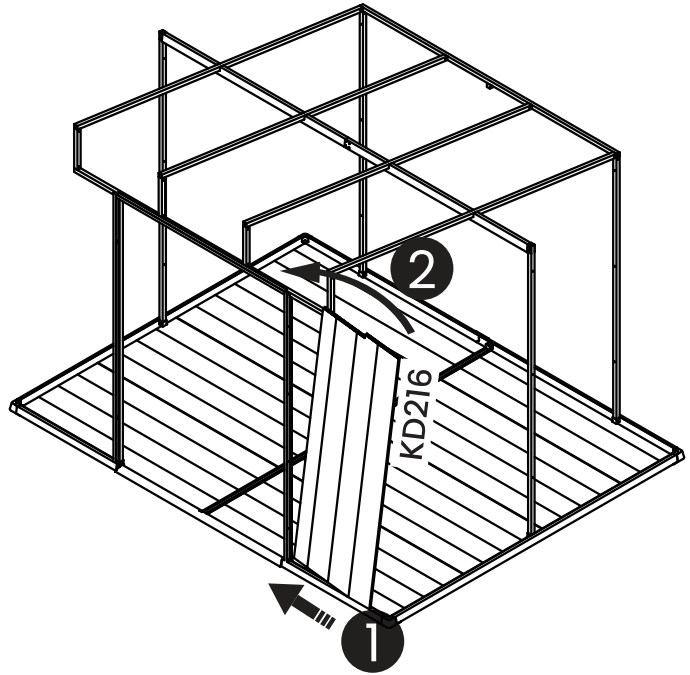
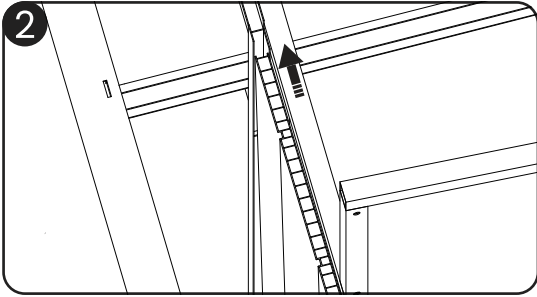
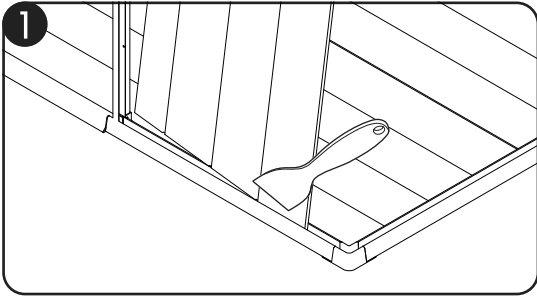

Étape 1 / Step 1

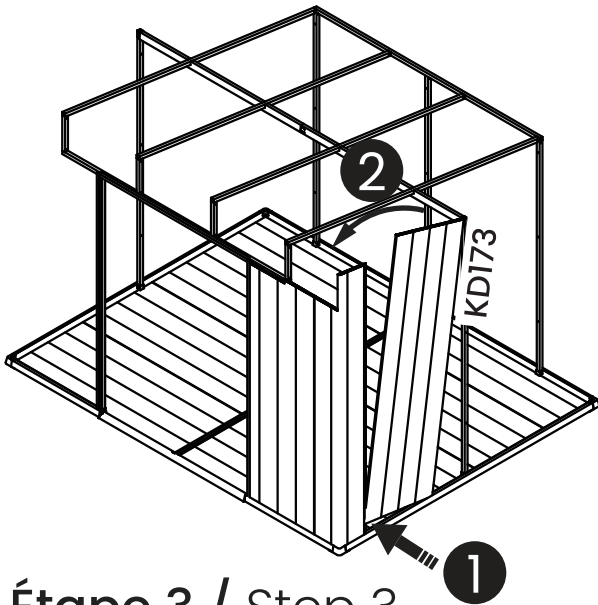

Étape 2 / Step 2

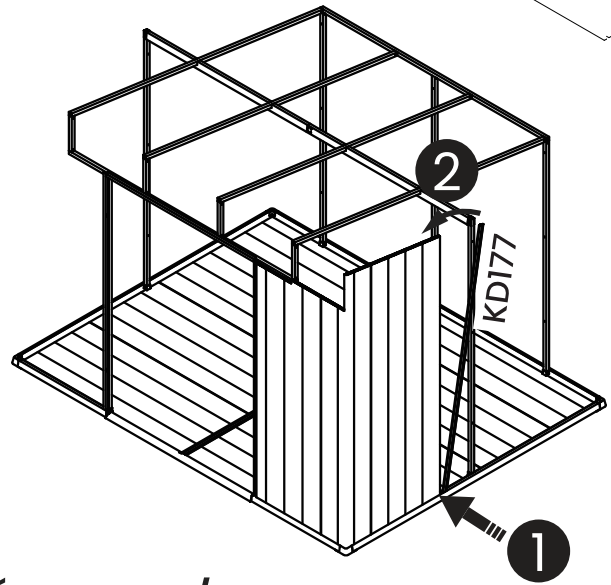

Étape 3 / Step 3

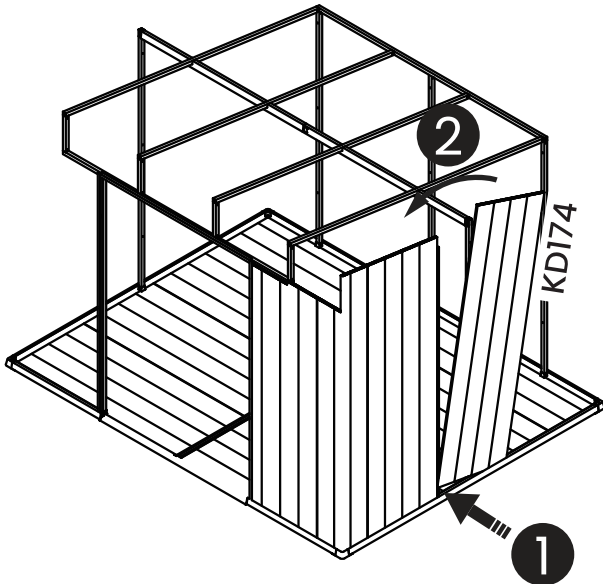

Étape 4 / Step 4

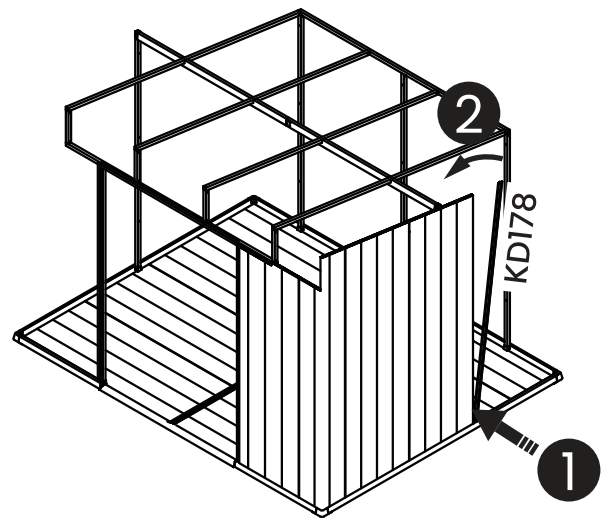

Étape 5 / Step 5

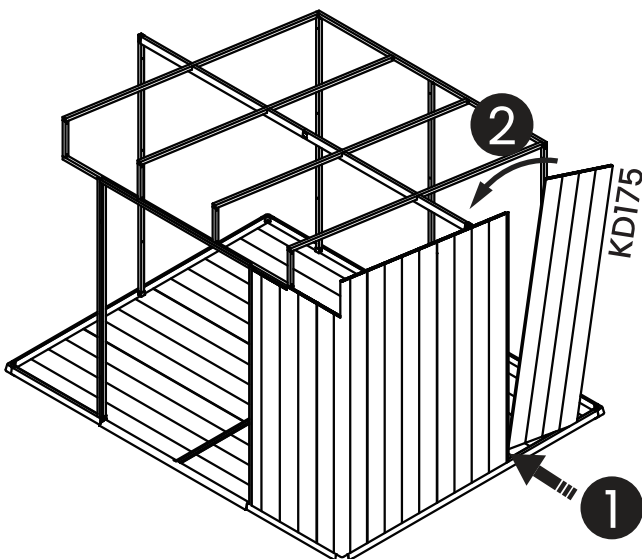

Étape 6 / Step 6

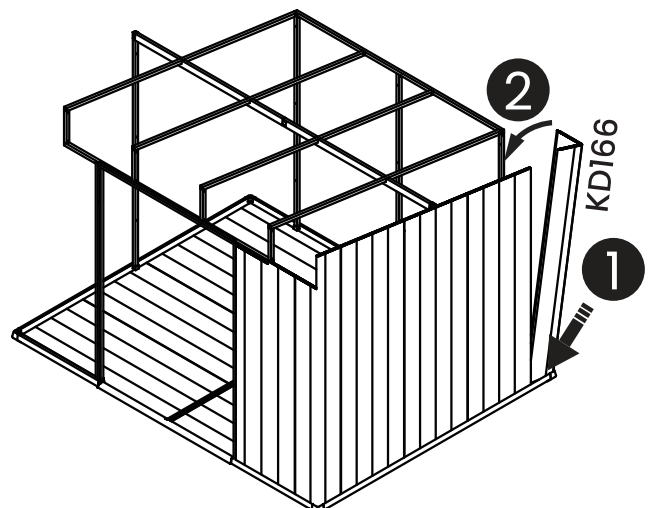

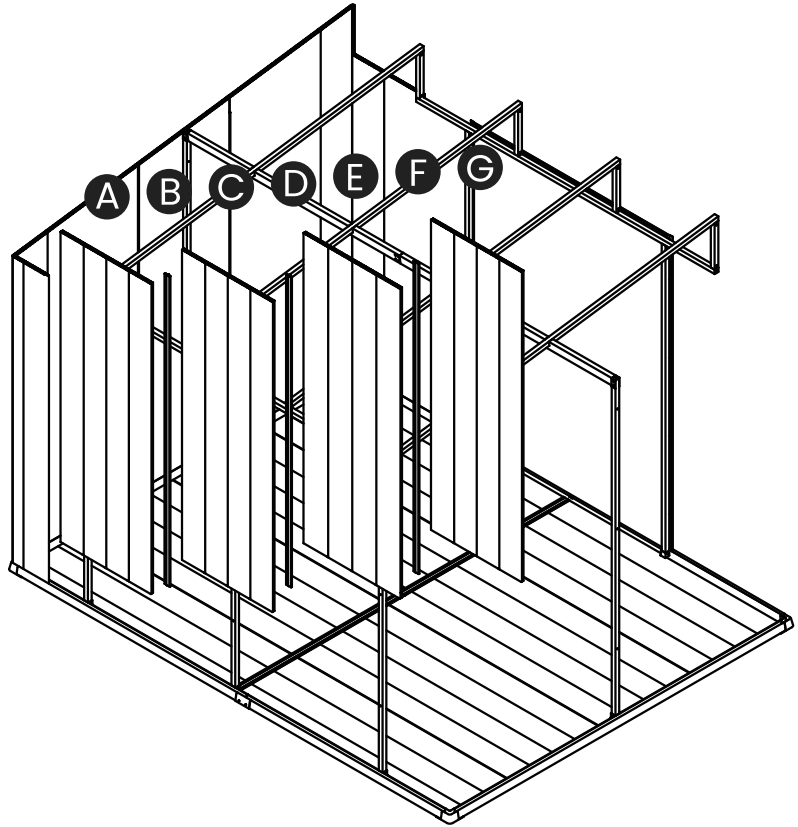
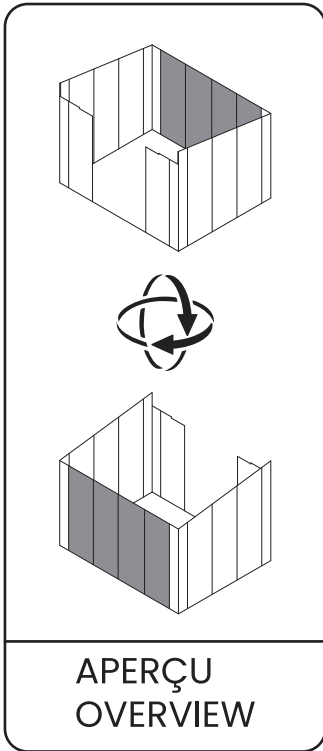

**A C G** KD169                      **E** KD217                      **B D F** KD176

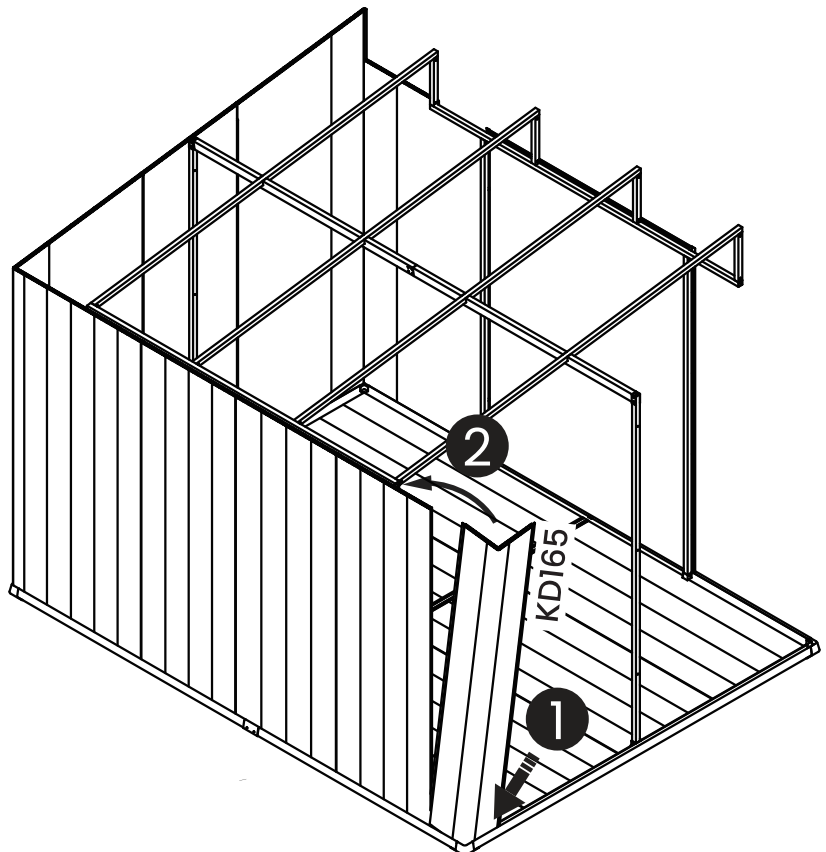
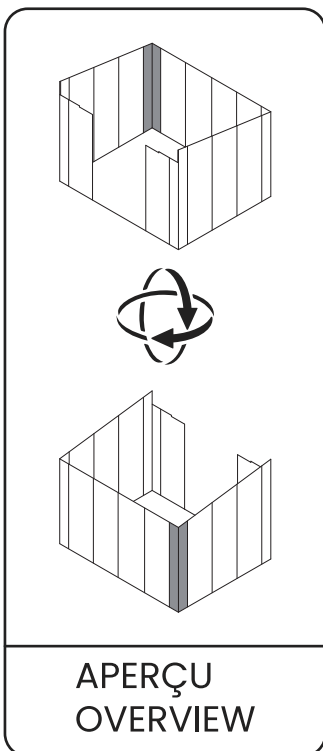



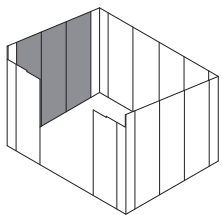

APERÇU  
OVERVIEW

- A** KD170
- B** KD177
- C** KD171
- D** KD178
- E** KD172

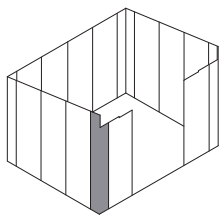
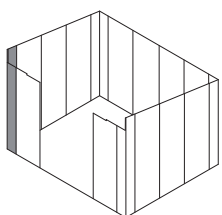
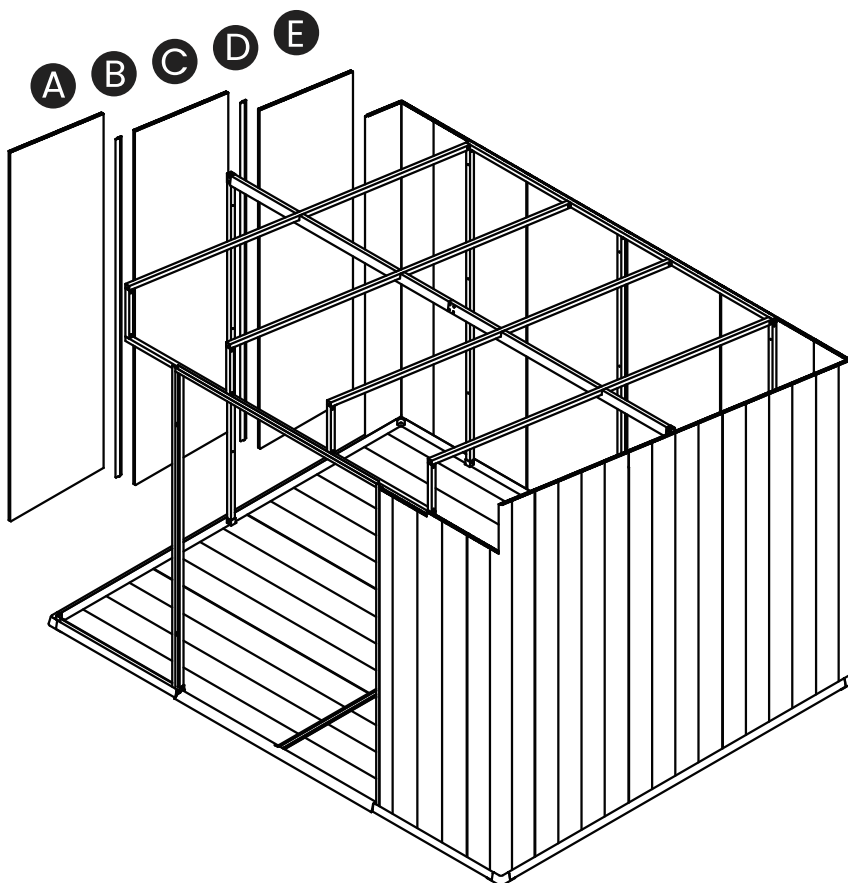

APERÇU  
OVERVIEW

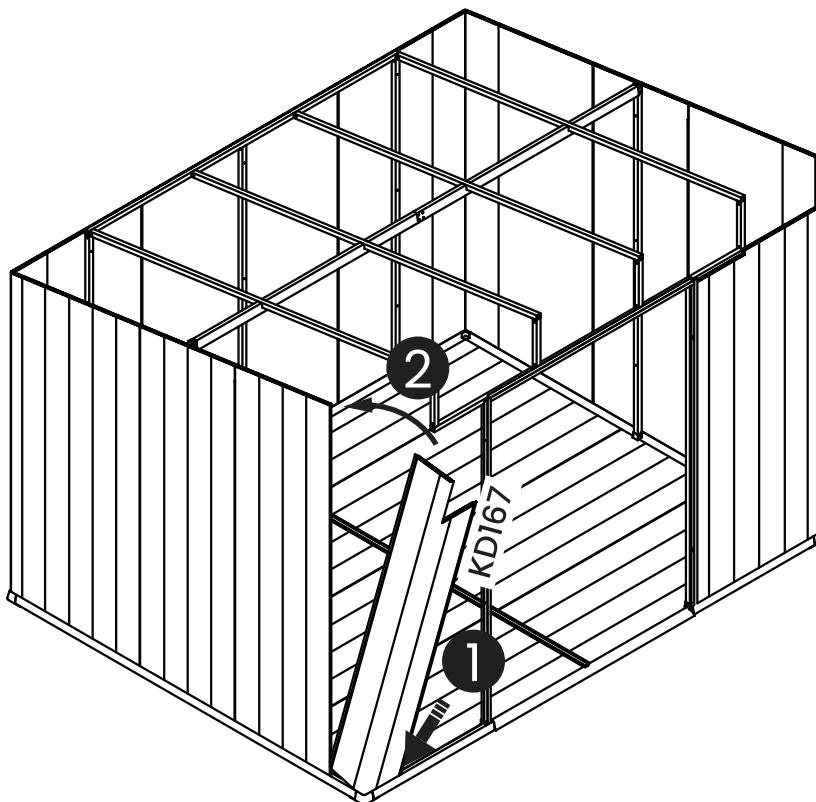

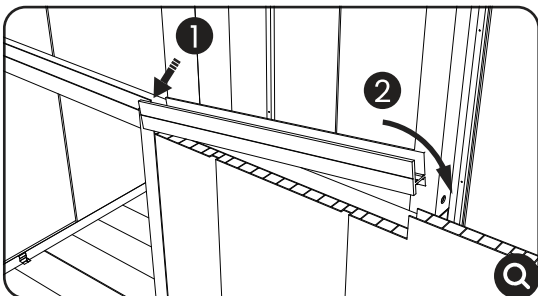
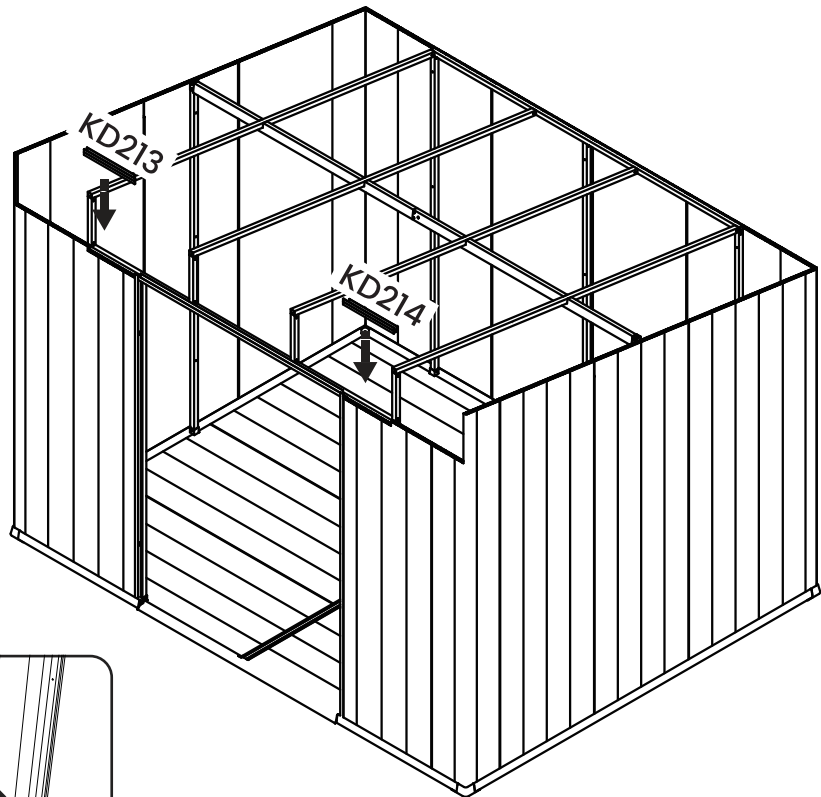
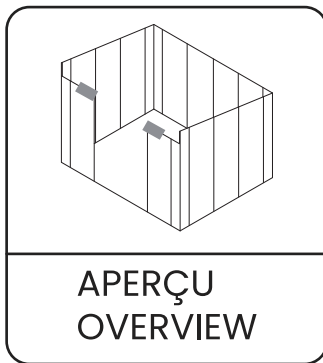
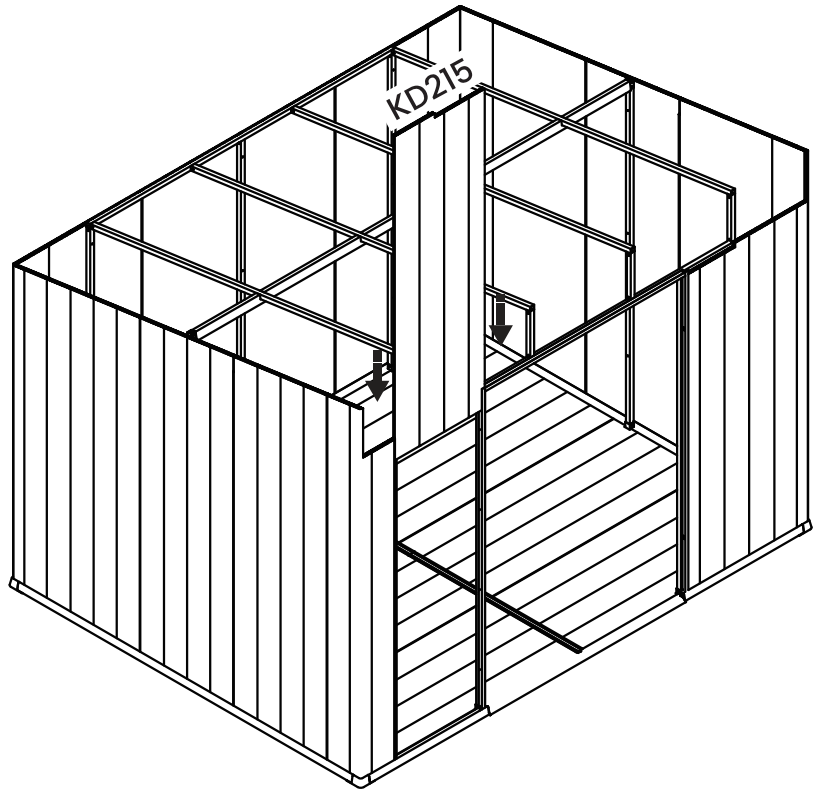
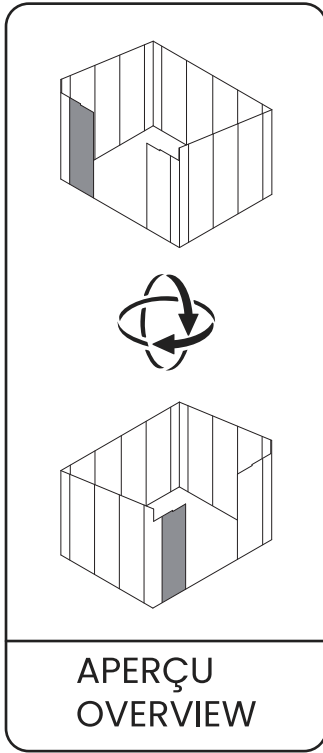

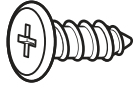

KD083

x18

**Il n'y a pas d'avant-trou proposé. Respectez la distance moyenne.**  
There is no pre-drill hole offered. Keep the distance averagely.

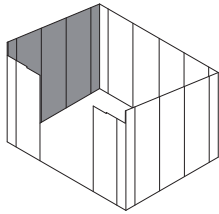

APERÇU  
OVERVIEW

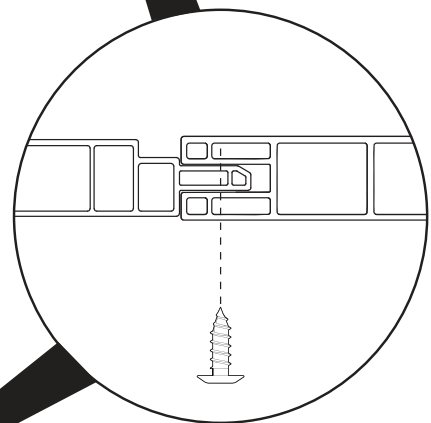
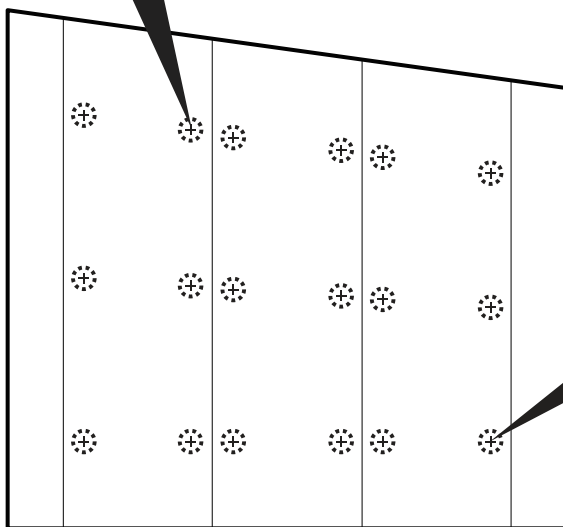
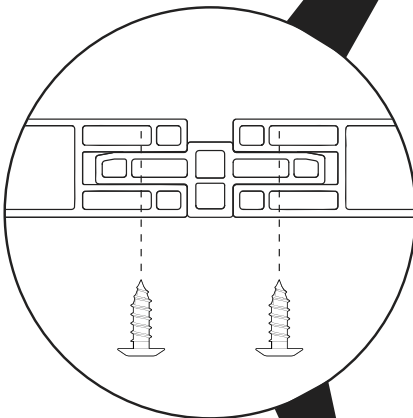
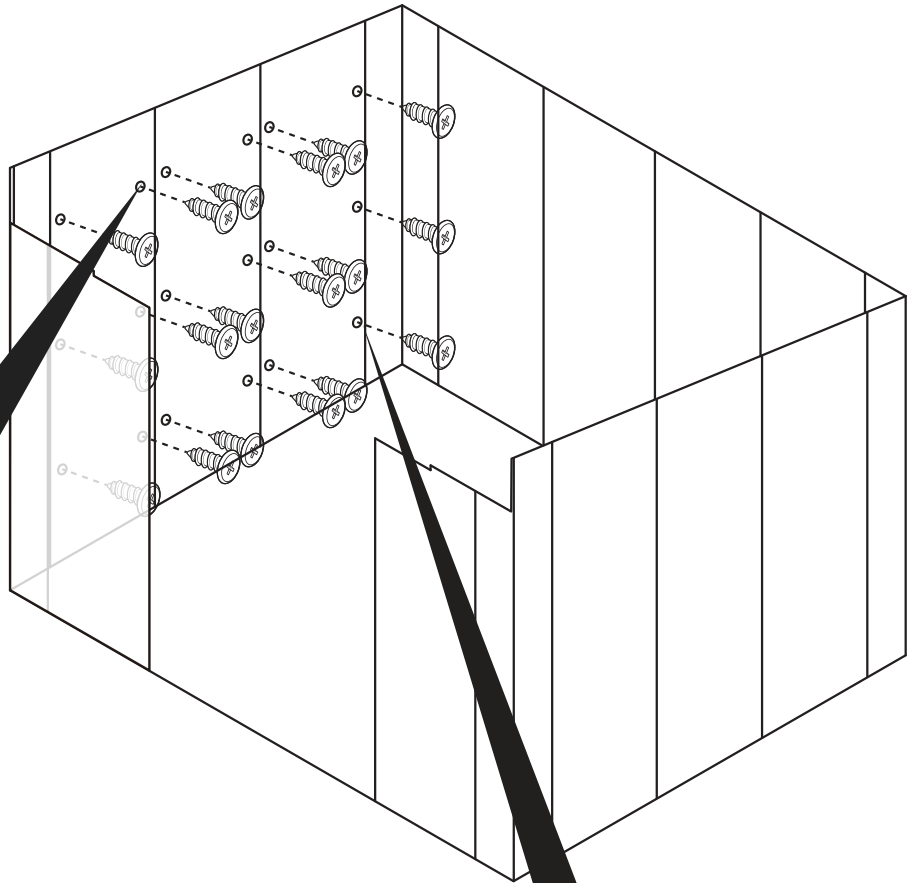

**Vue intérieur projetée**  
Inside Projected View

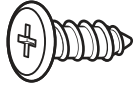

KD083

x24

**Il n'y a pas d'avant-trou proposé. Respectez la distance moyenne.**  
There is no pre-drill hole offered. Keep the distance averagely.

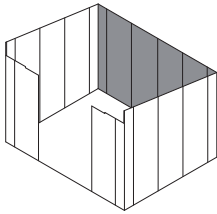

APERÇU  
OVERVIEW

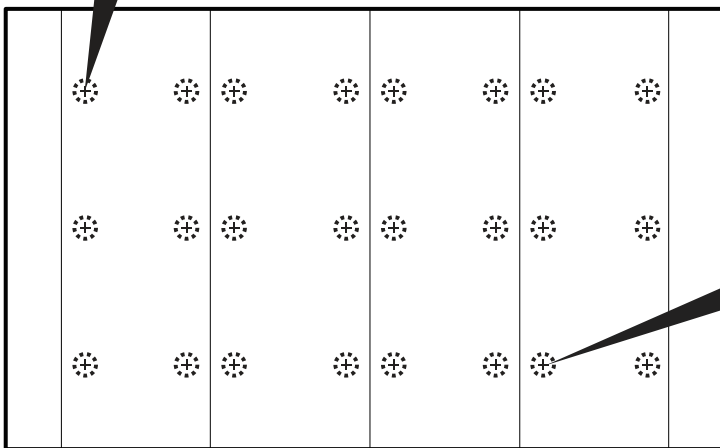
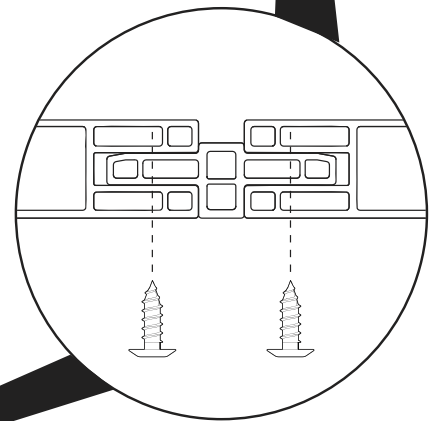
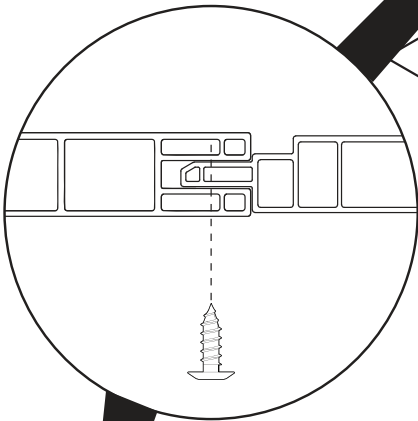
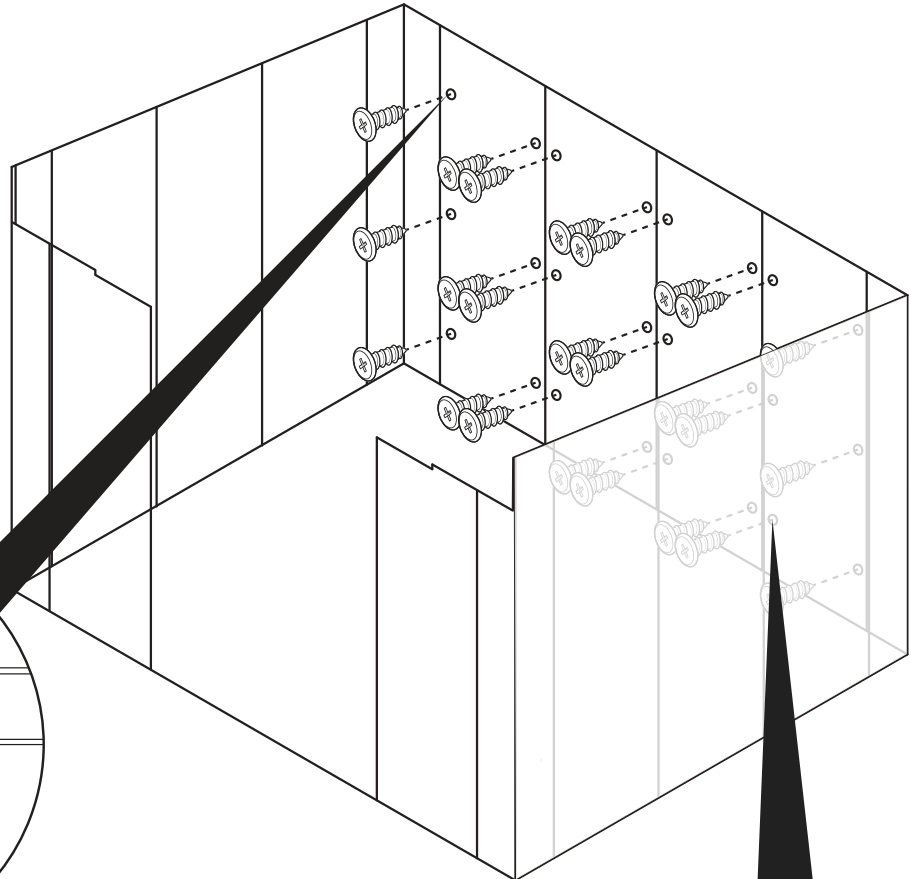

**Vue intérieur projetée**  
Inside Projected View

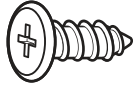

KD083

x18

**Il n'y a pas d'avant-trou proposé. Respectez la distance moyenne.**  
There is no pre-drill hole offered. Keep the distance averagely.

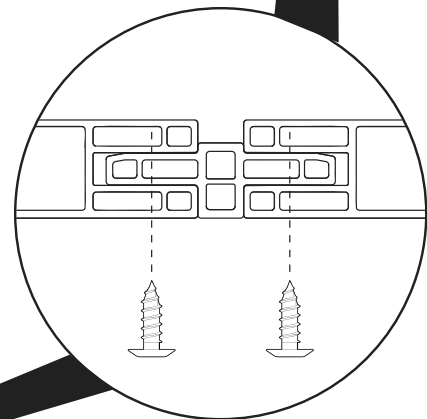
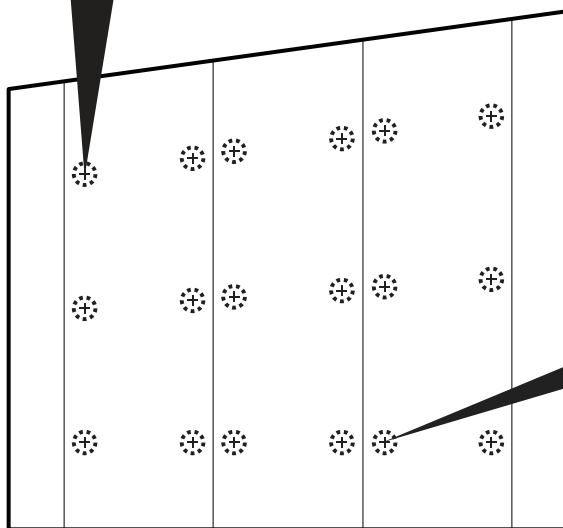
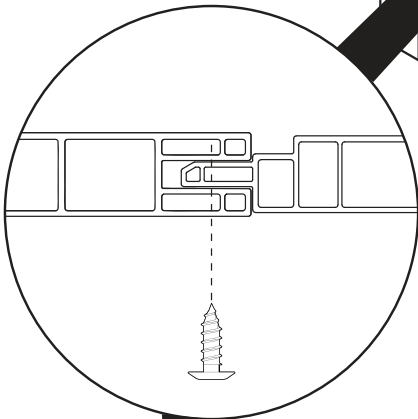
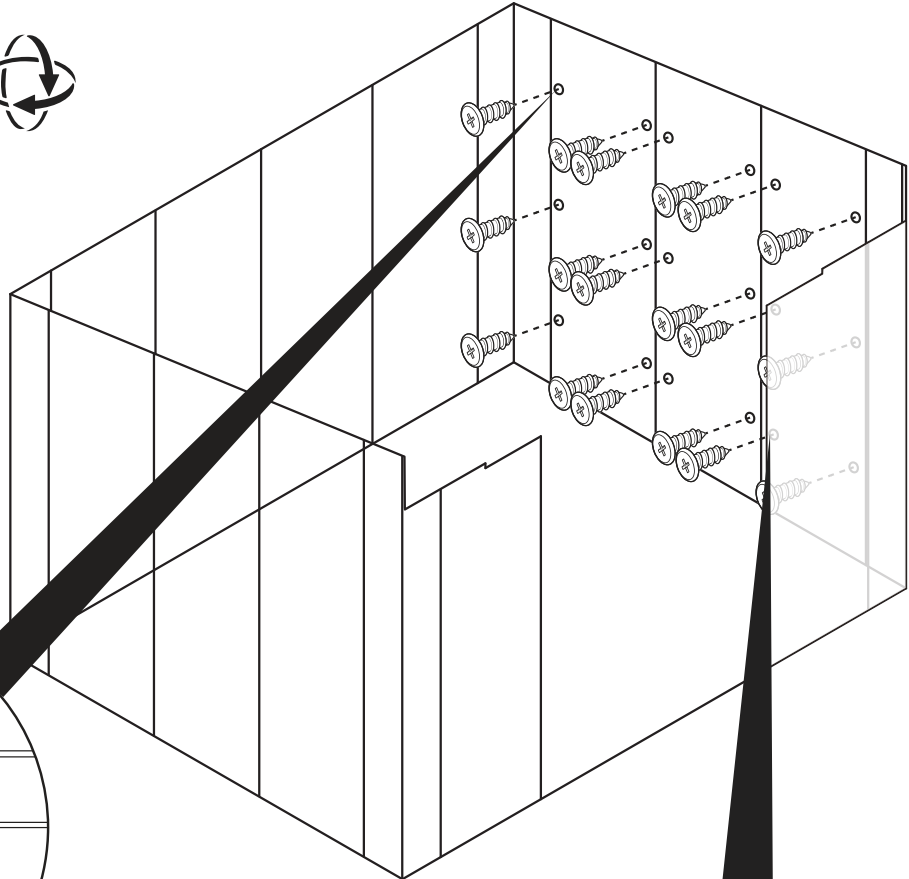
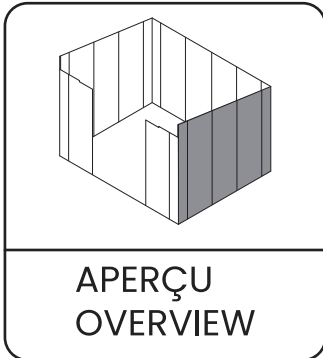

**Vue intérieur projetée**  
Inside Projected View

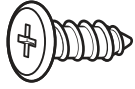

KD083

x14

**Il n'y a pas d'avant-trou proposé. Respectez la distance moyenne.**  
There is no pre-drill hole offered. Keep the distance averagely.

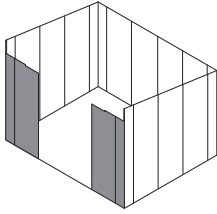

APERÇU  
OVERVIEW

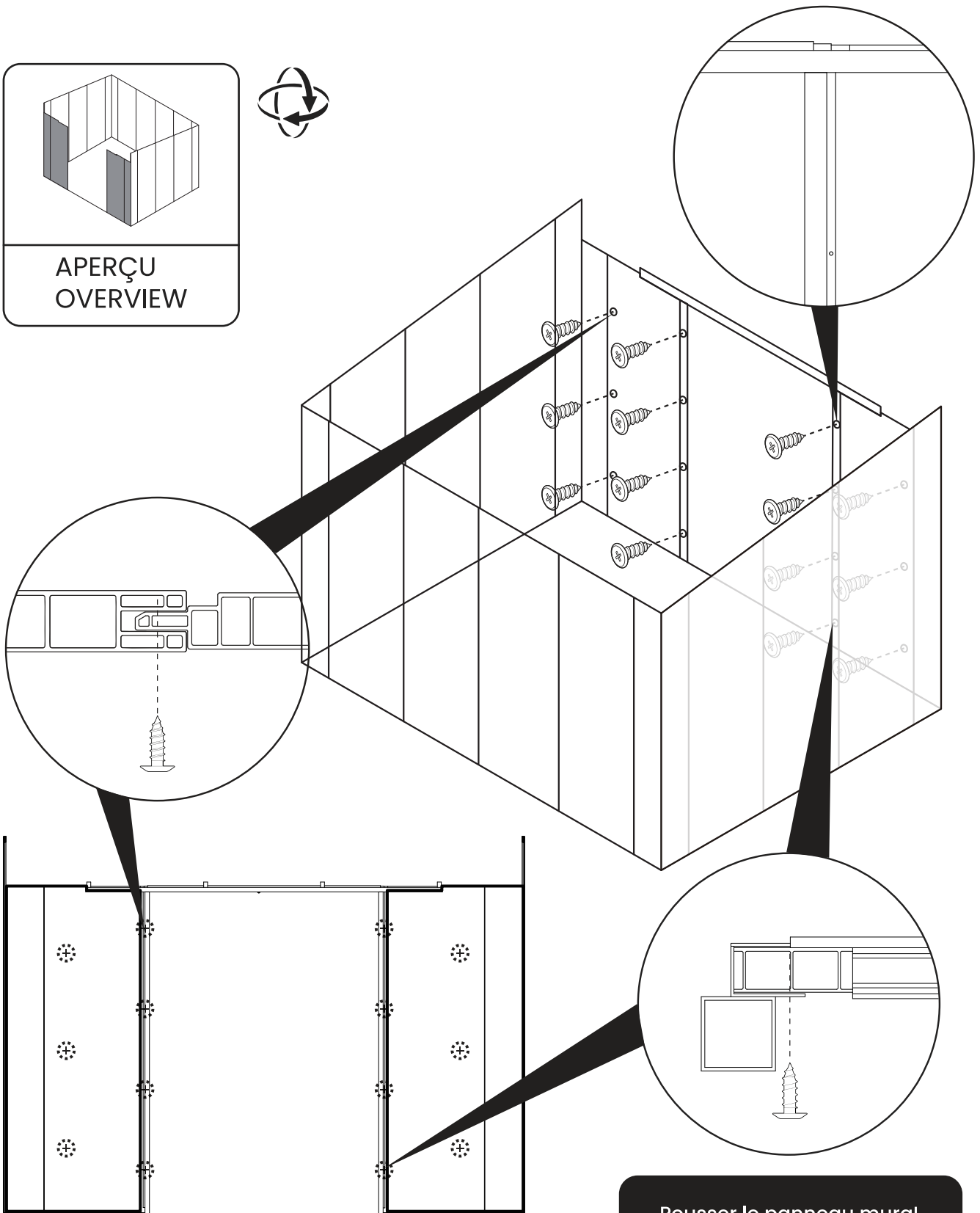

**Pousser le panneau mural  
jusqu'au bout avant  
de le verrouiller.**

Push the wall panel to  
the end before locking.

# Assemblage de fenêtre

## Window Assembly

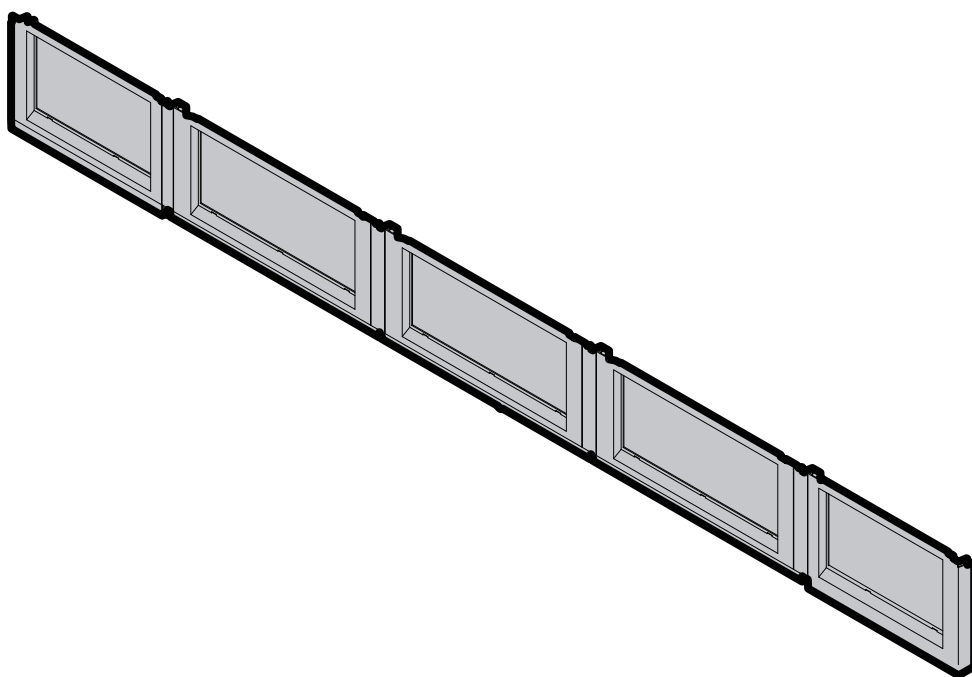





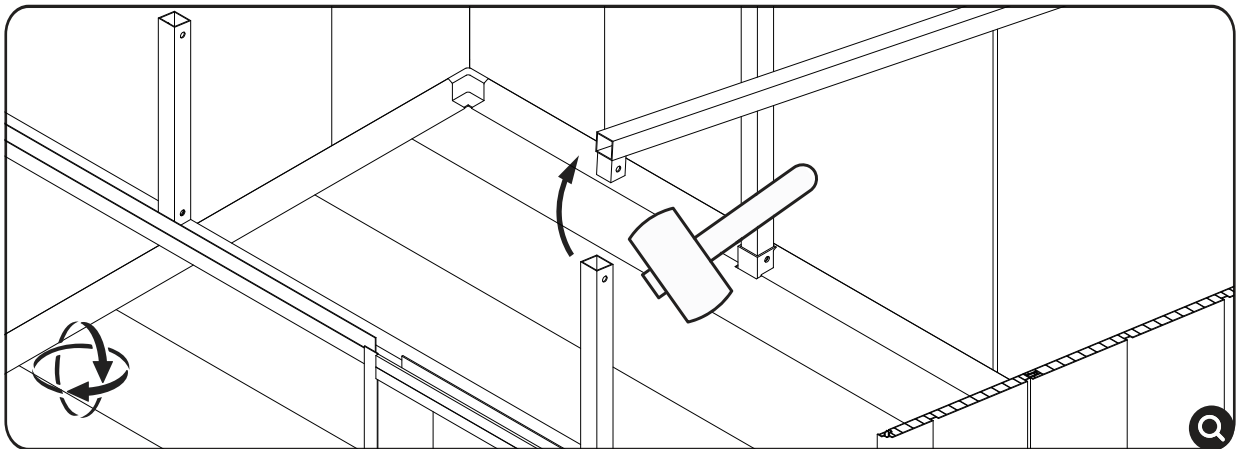
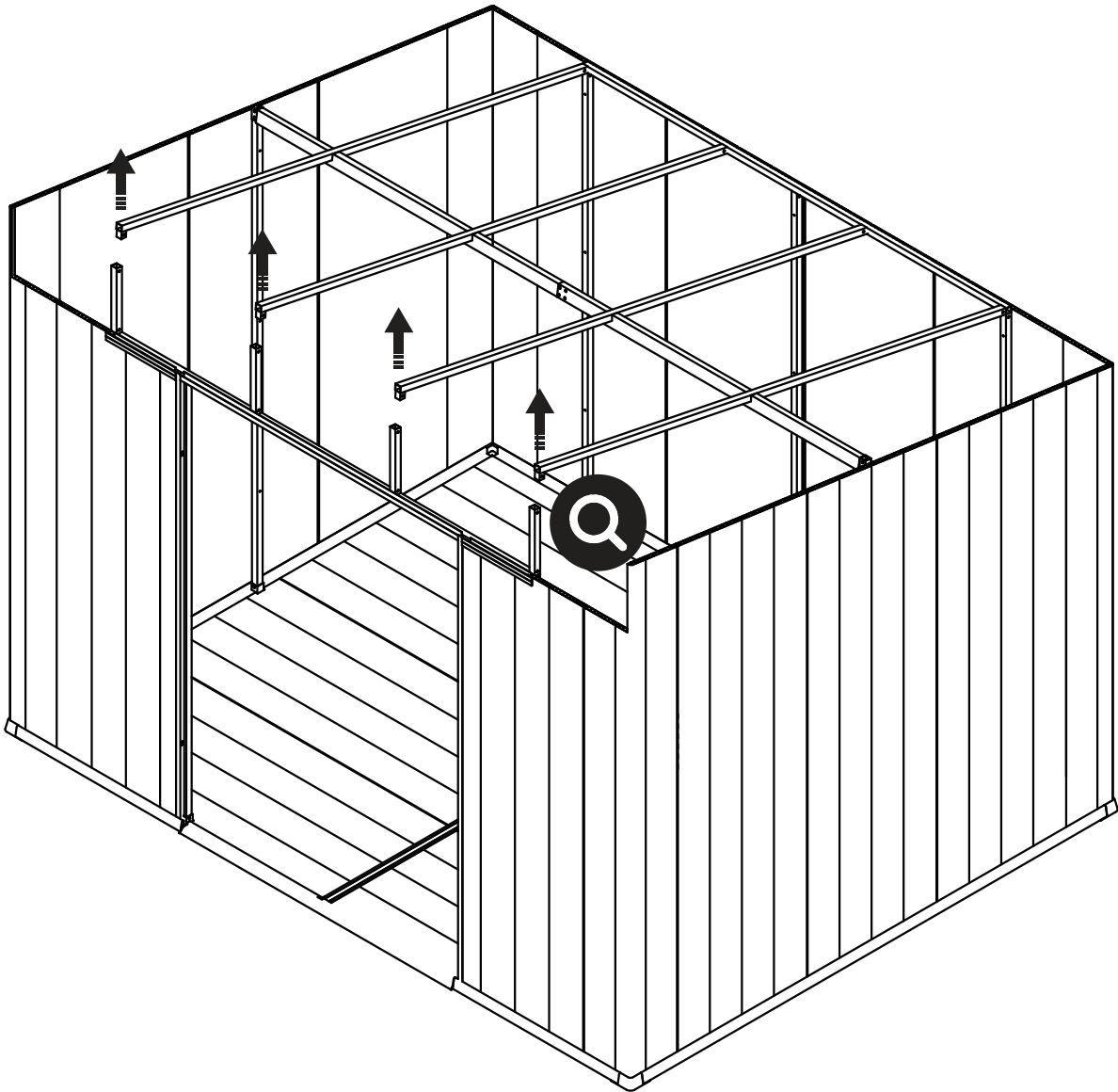

# SÉPARATION / SEPARATE

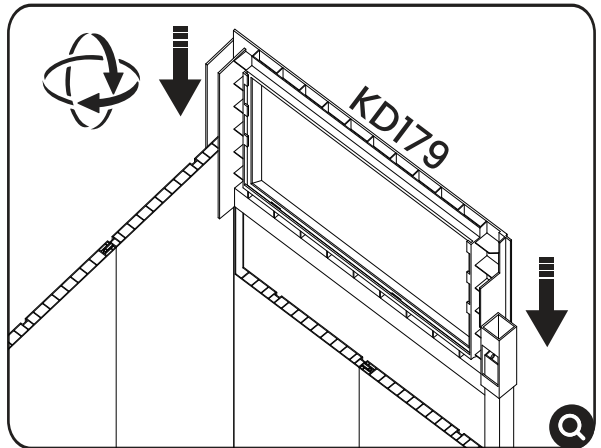
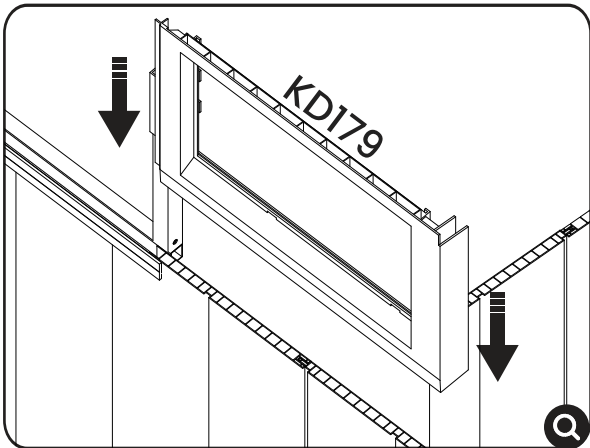
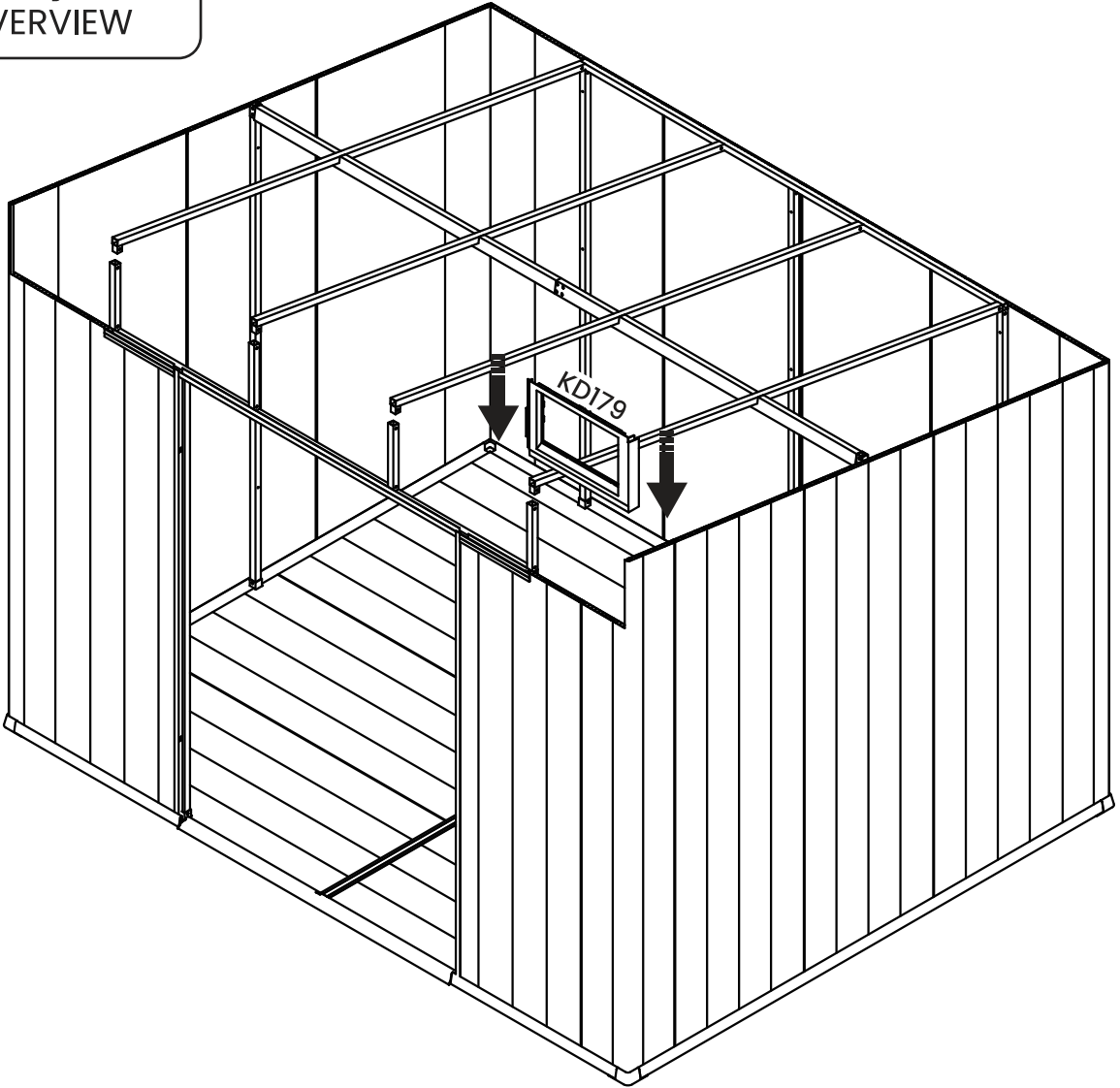
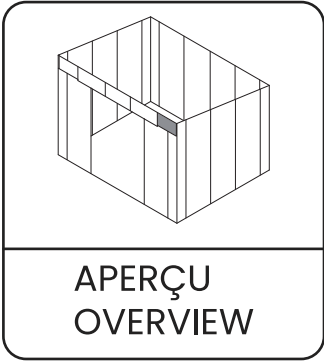

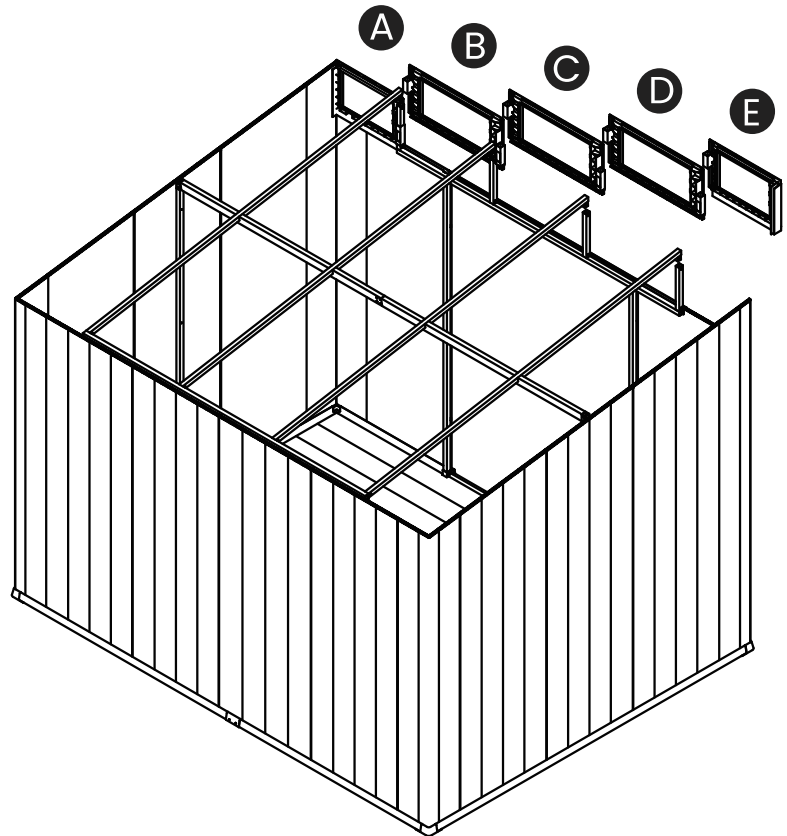
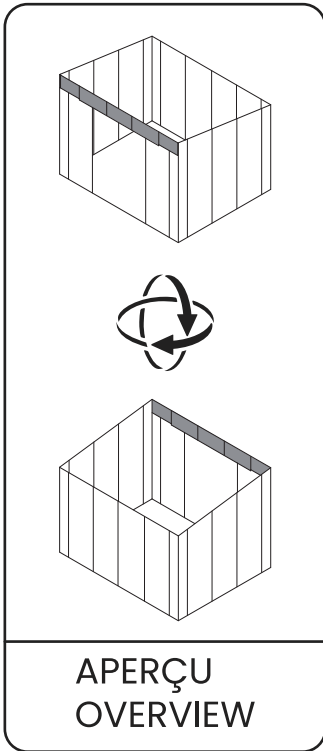

**A** KD179

**B C D** KD181

**E** KD180

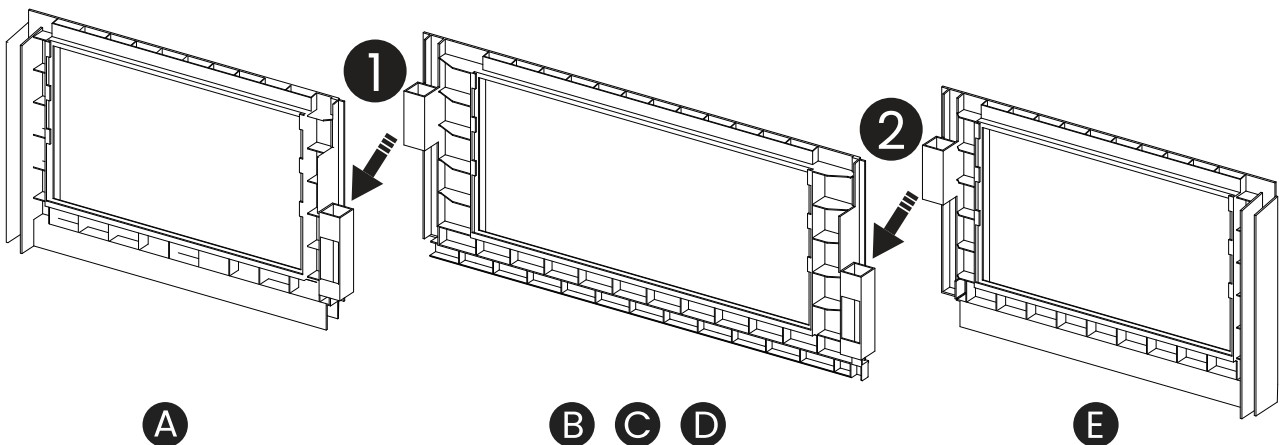

**LES INSTALLER DANS L'ORDRE A-E**  
**INSTALL THEM IN SEQUENCE A-E**

	KD081	x4		KD082	x4
---	-------	----	--	-------	----

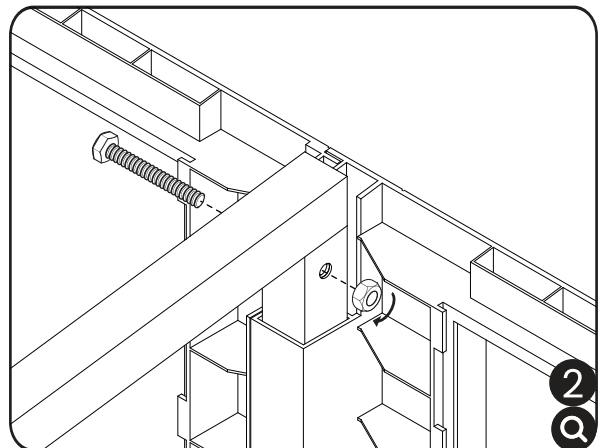
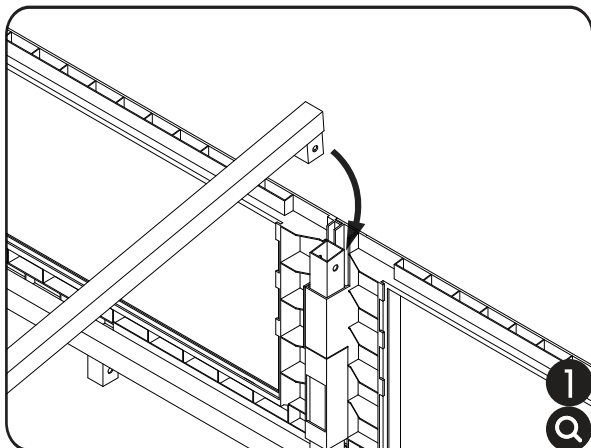
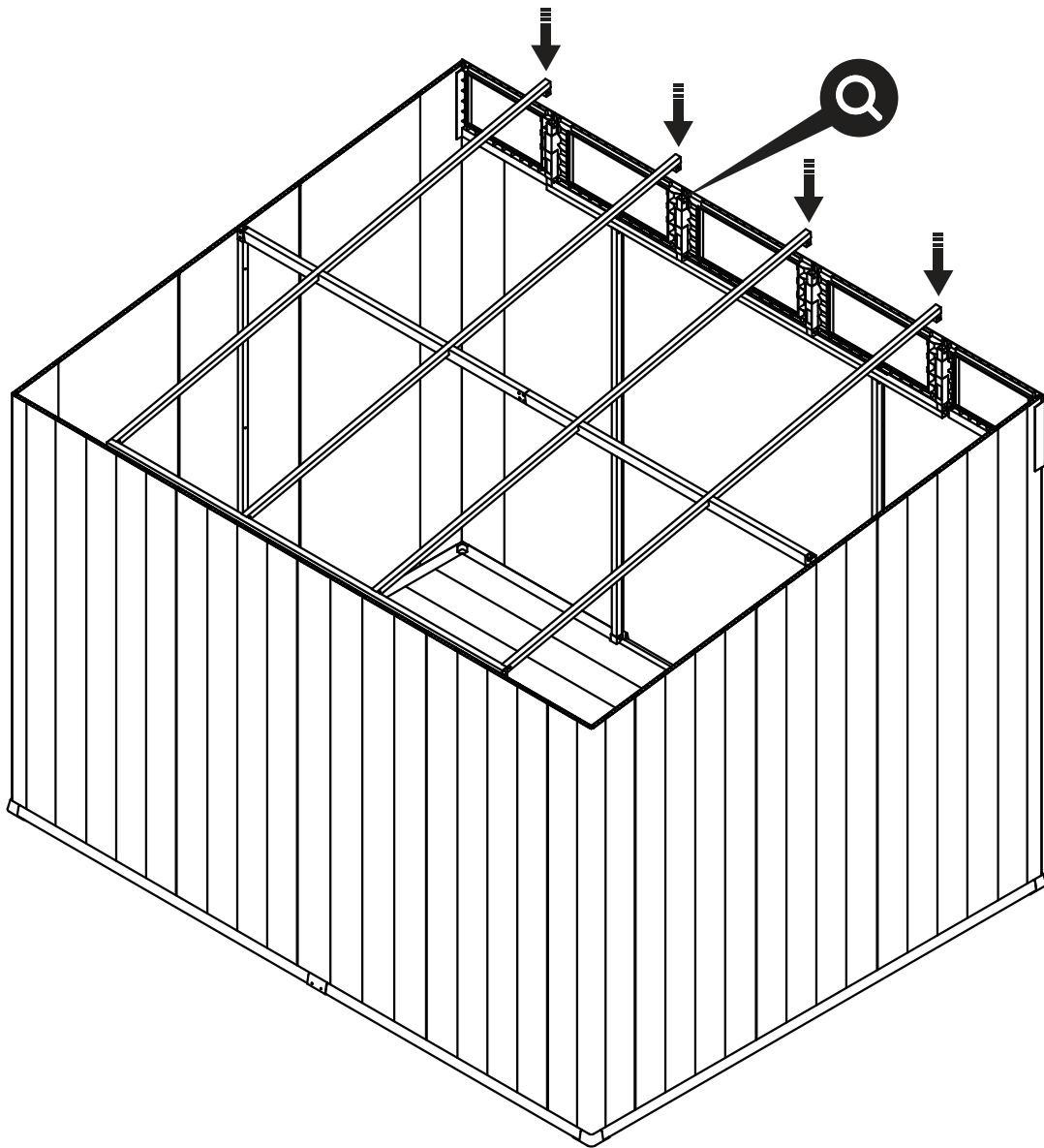

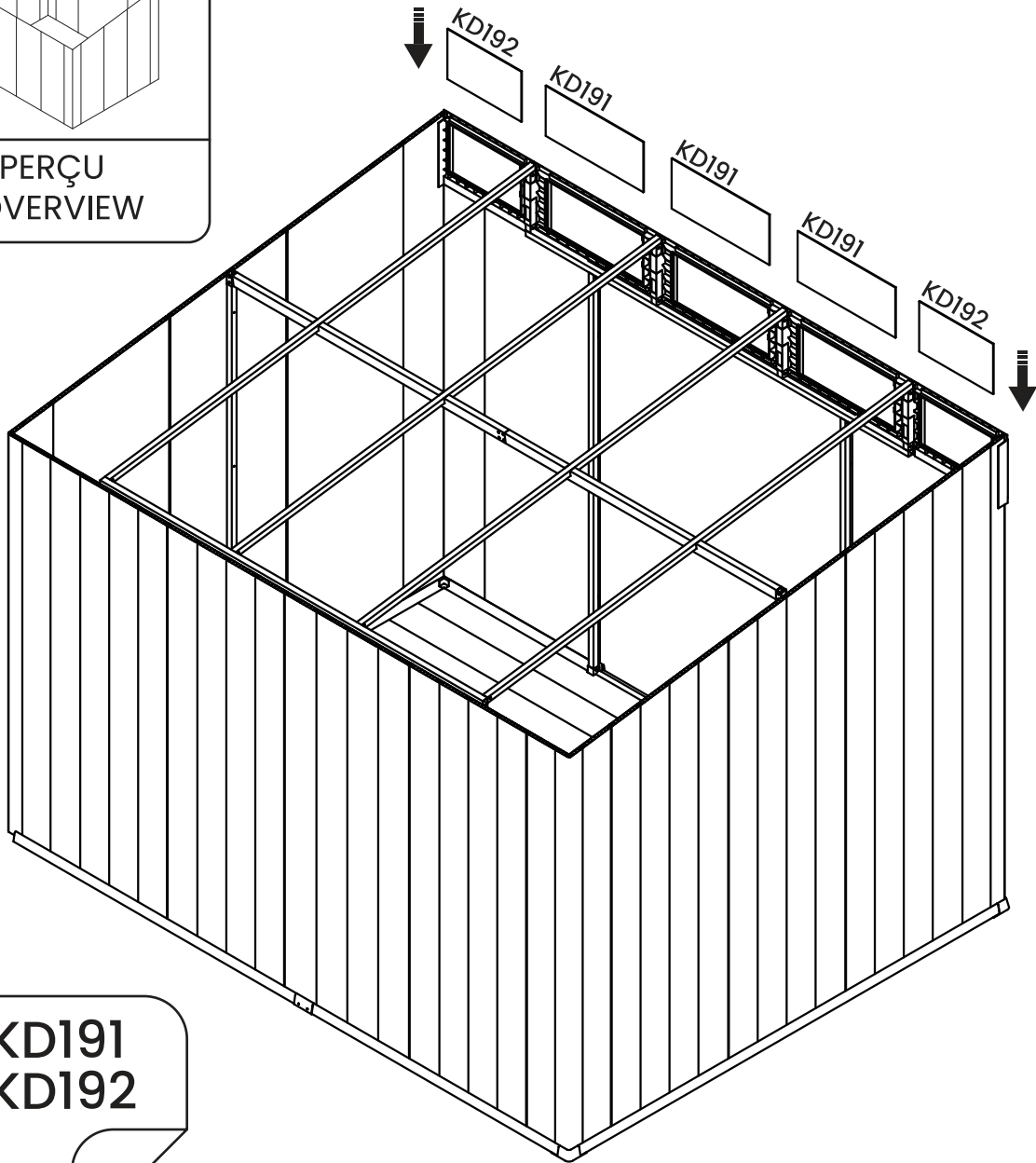
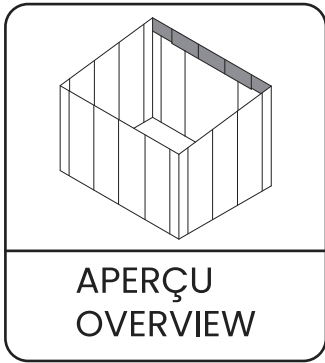

**KD191  
KD192**

**Décoller le film avant l'installation.**  
Peel off the film before installation.

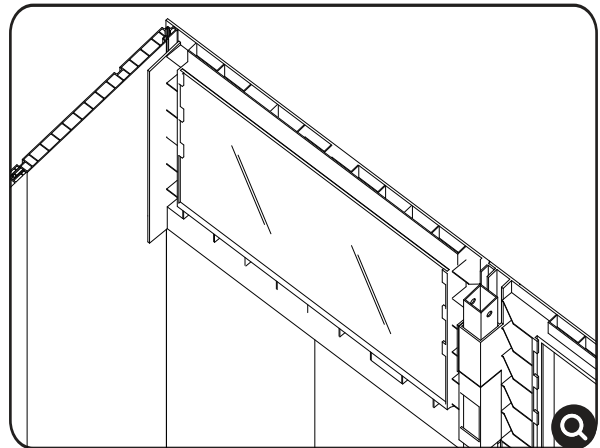
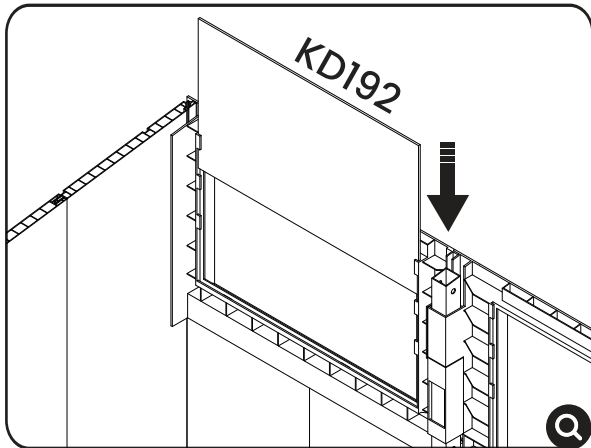

	KD081	x7		KD018	x7
---	-------	----	--	-------	----

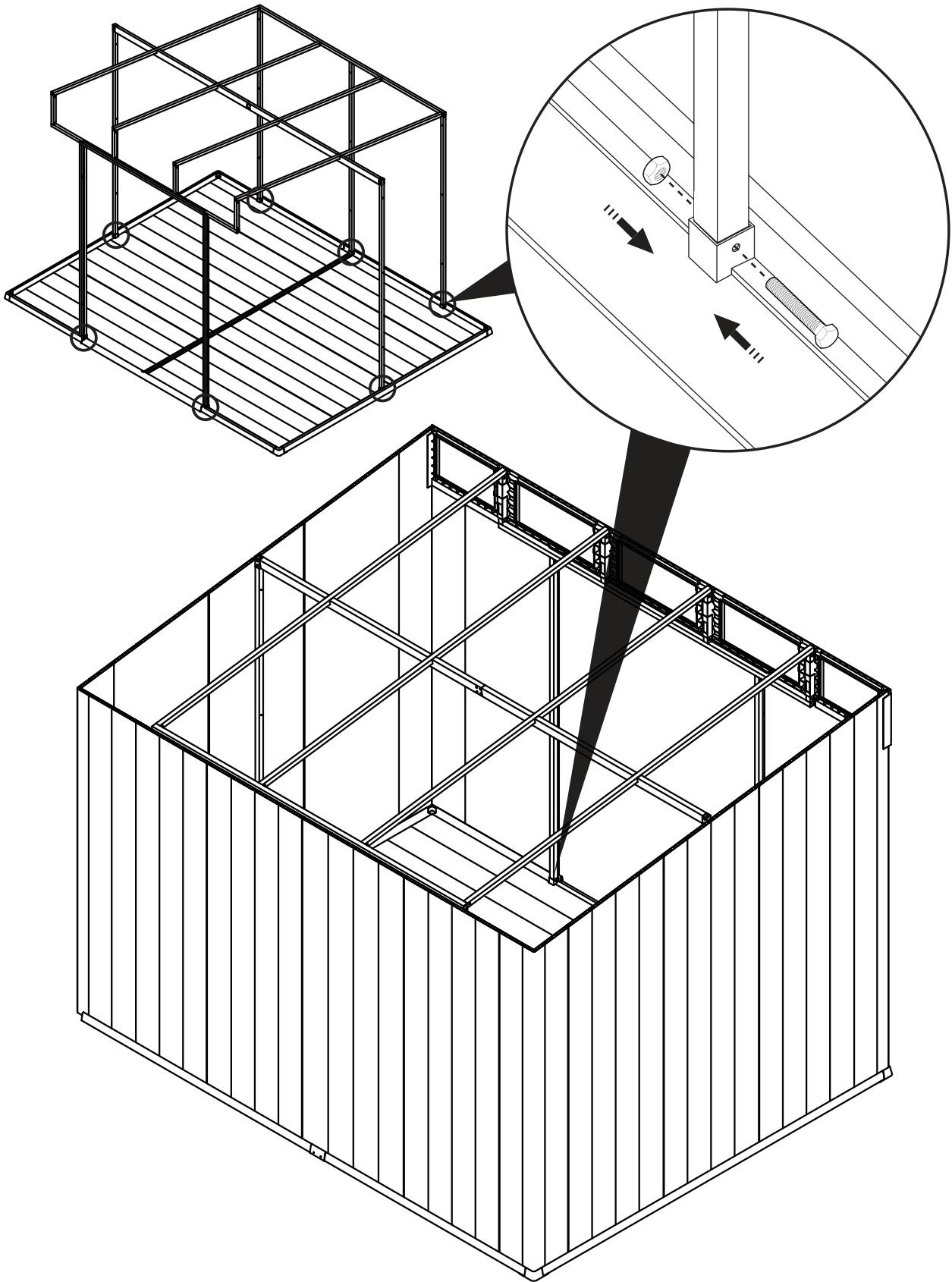

**Visser le tout fermement après avoir posé le cadre.**  
 Screw all of it tightly after laying down the frame.

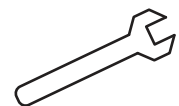

# Assemblage du toit

## Roof Assembly

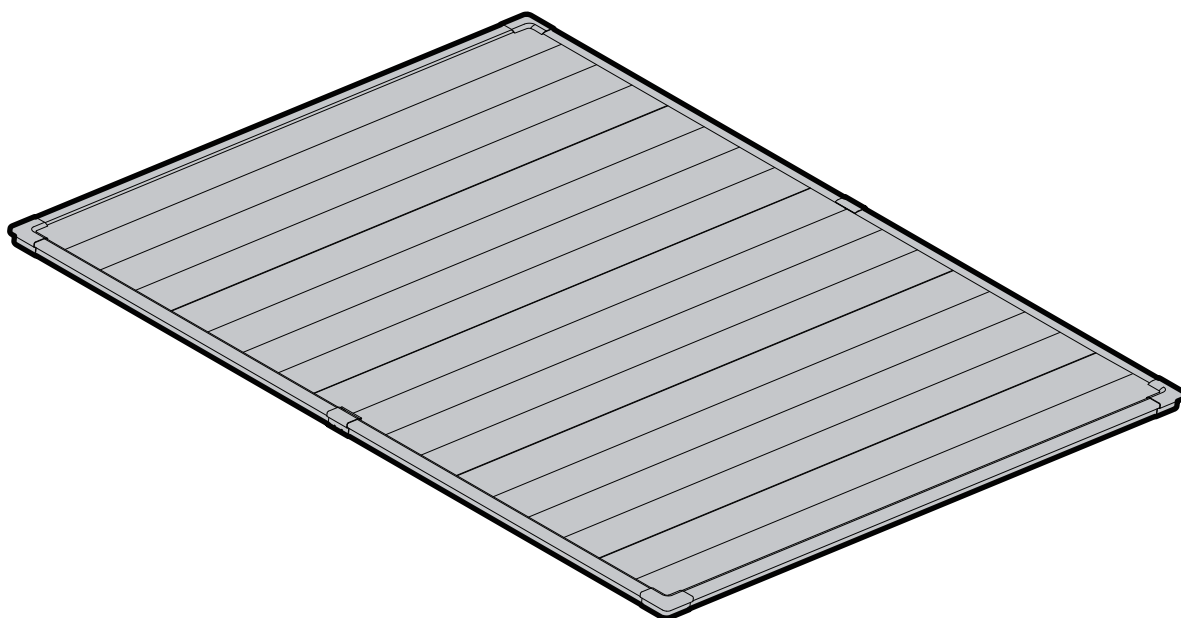





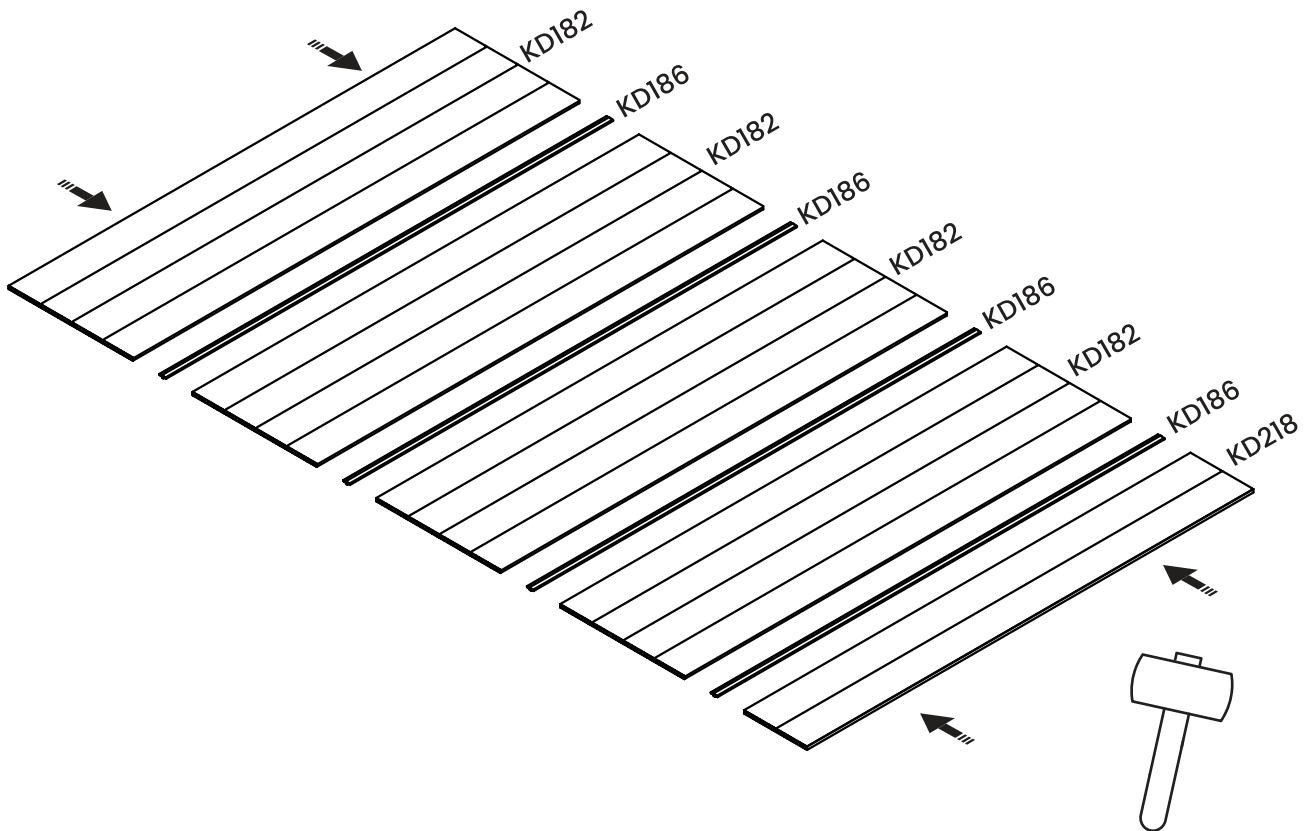
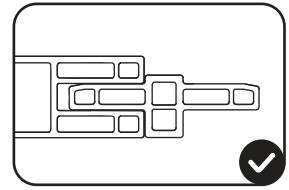
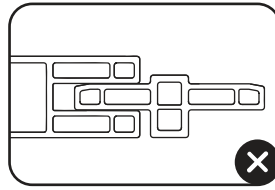
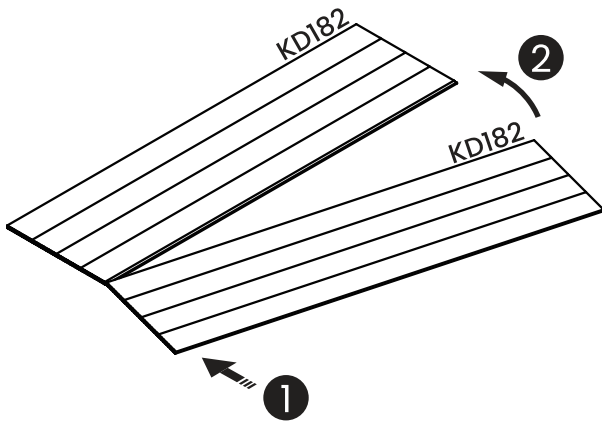
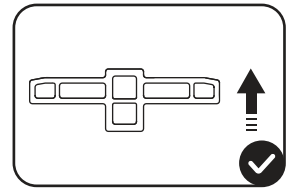
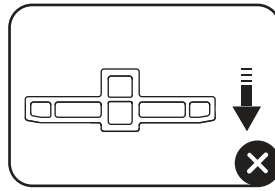
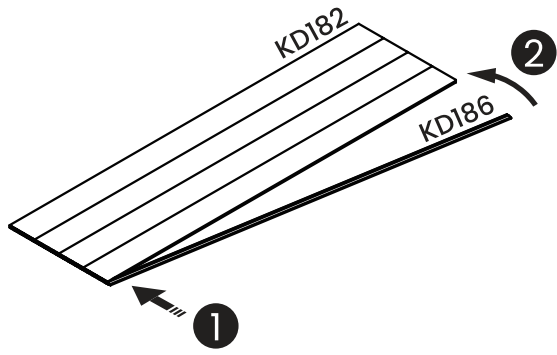

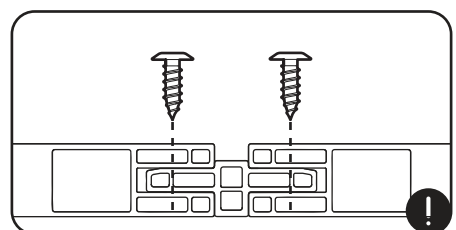
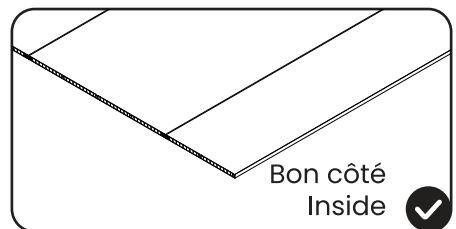
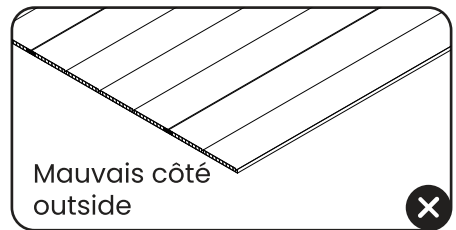
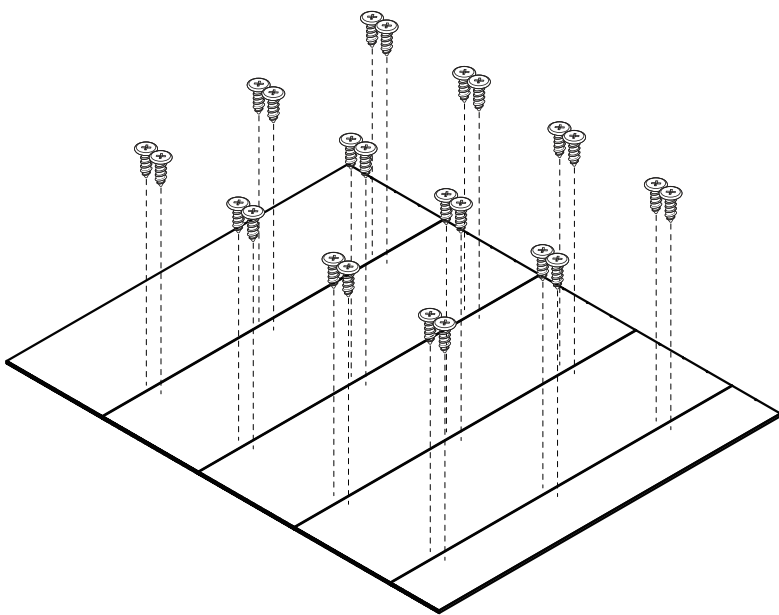
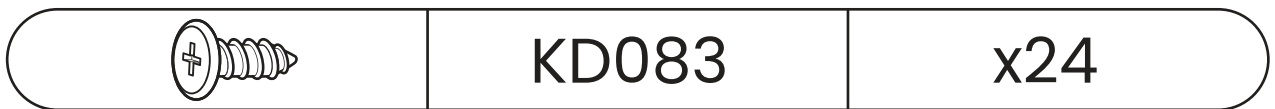
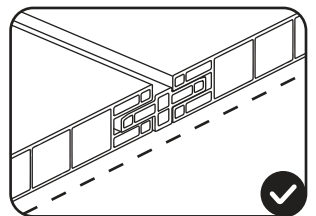
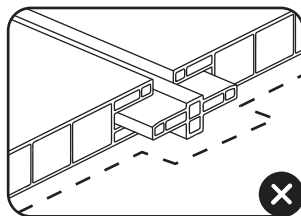
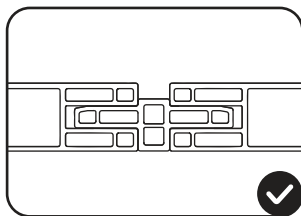
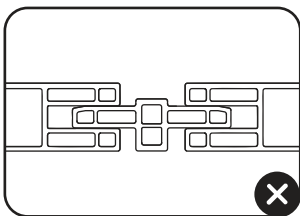
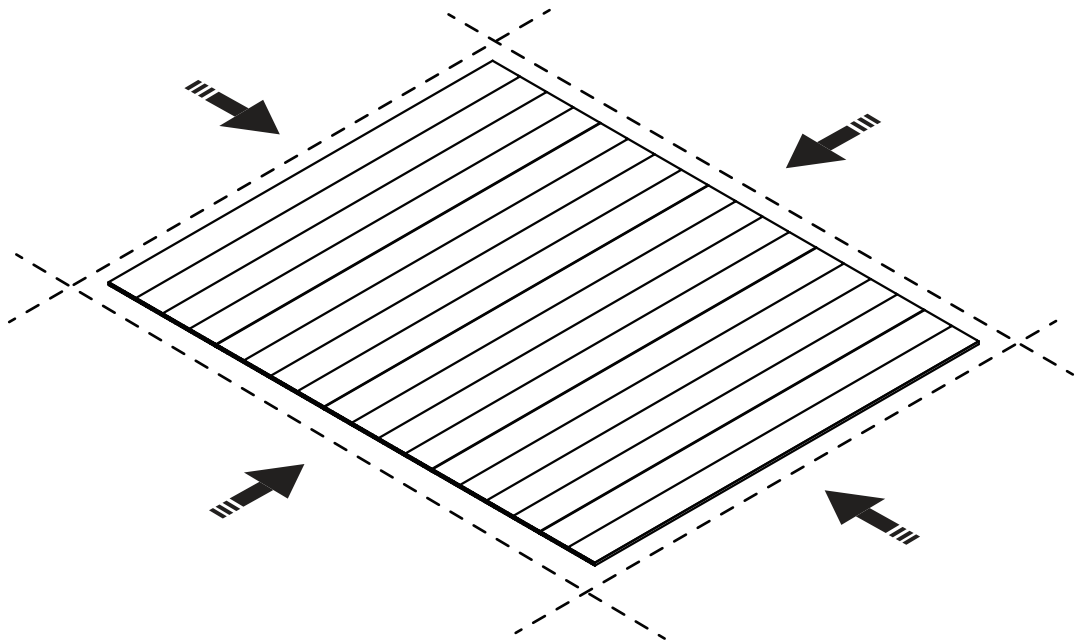

**Veillez bloquer la vis sur le côté intérieur.**  
Please lock the screw on the inner side.

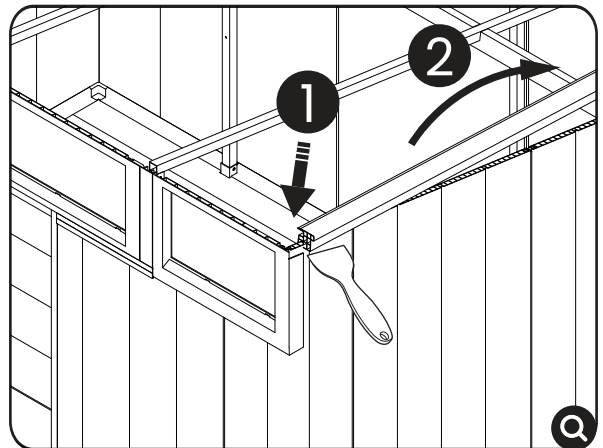
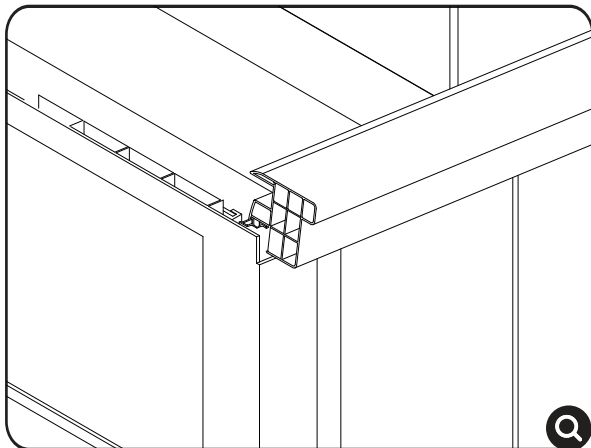
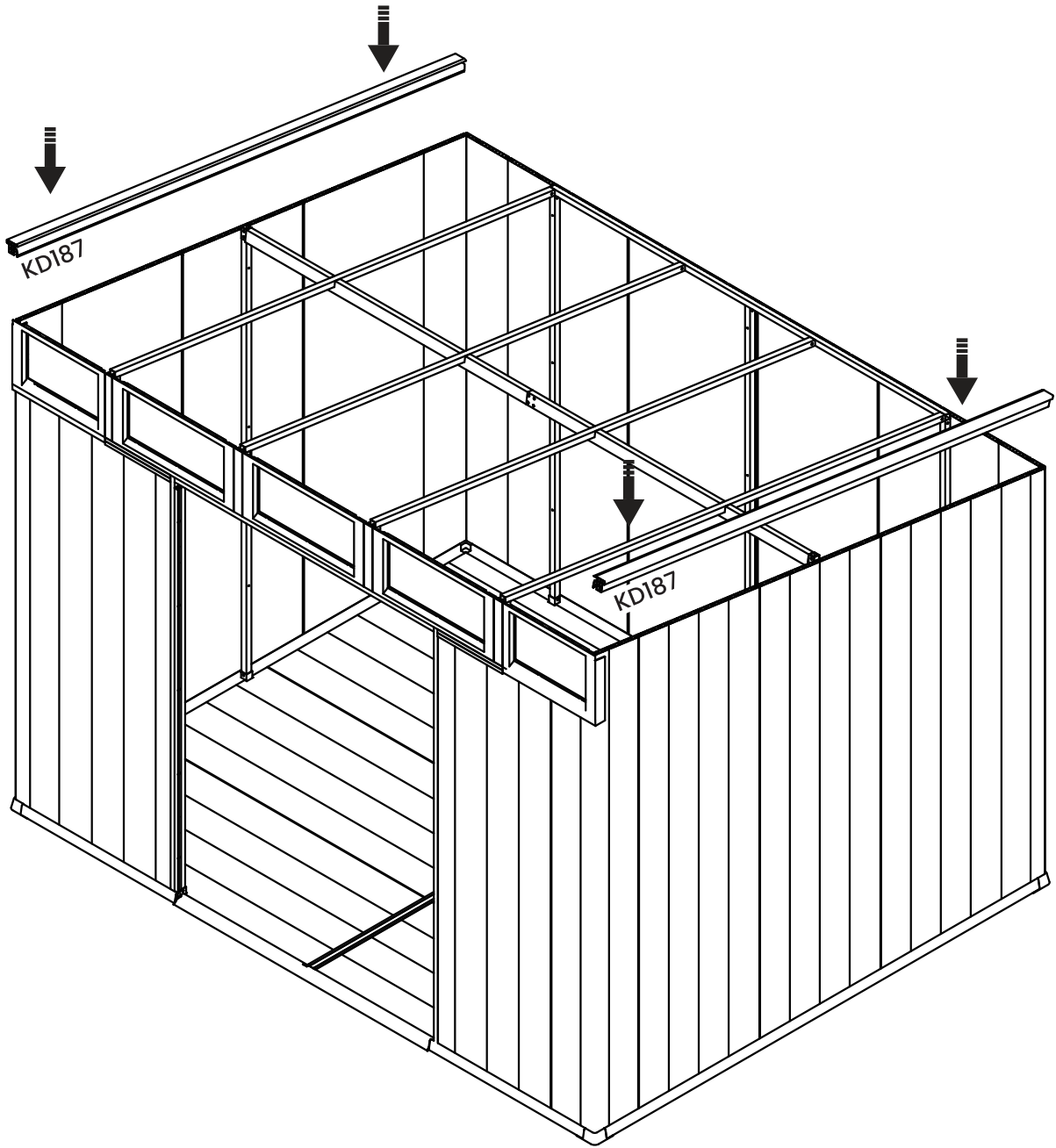

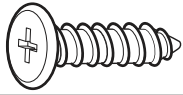

KD084

x16

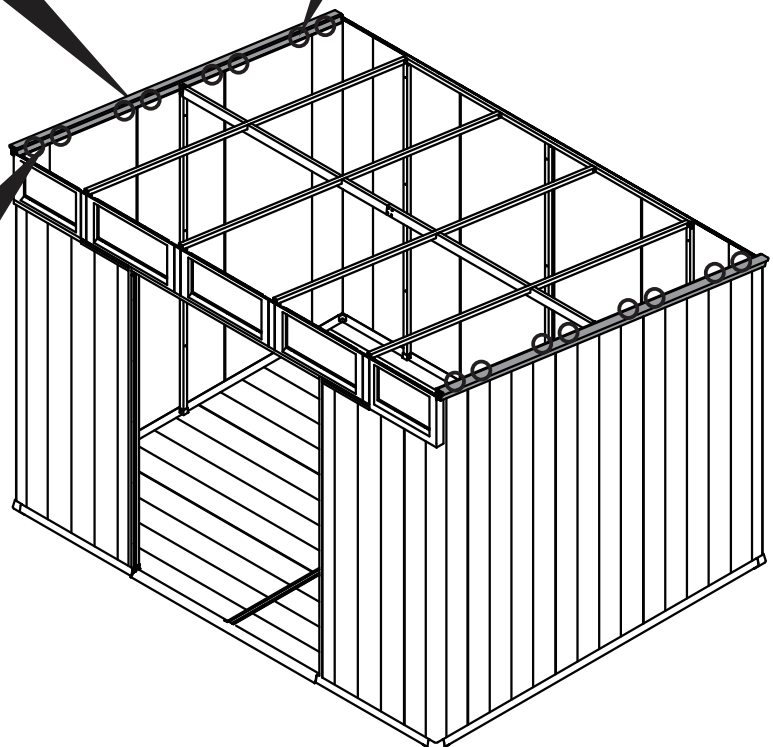
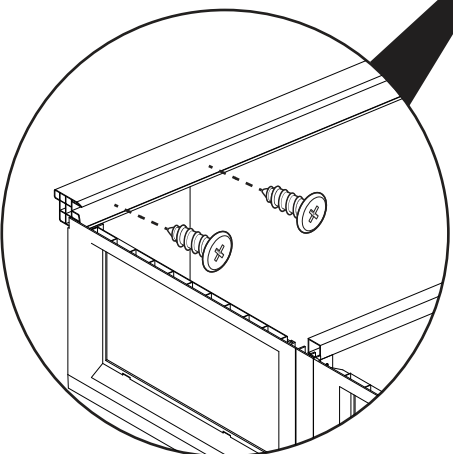
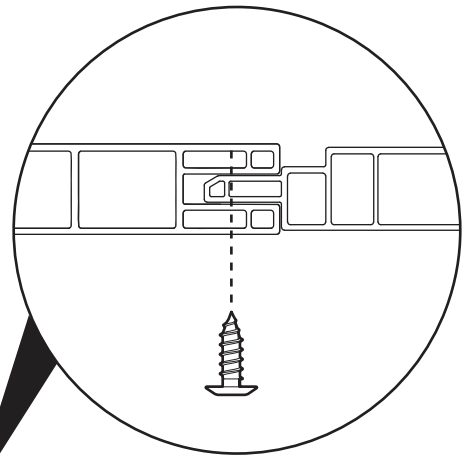
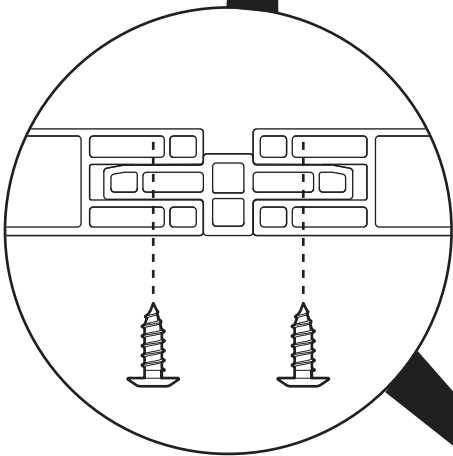
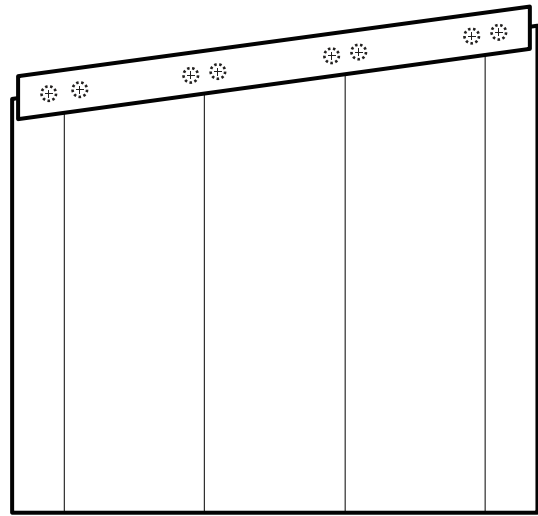
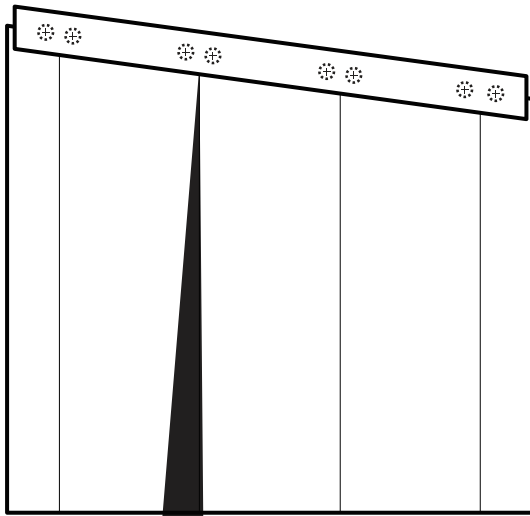

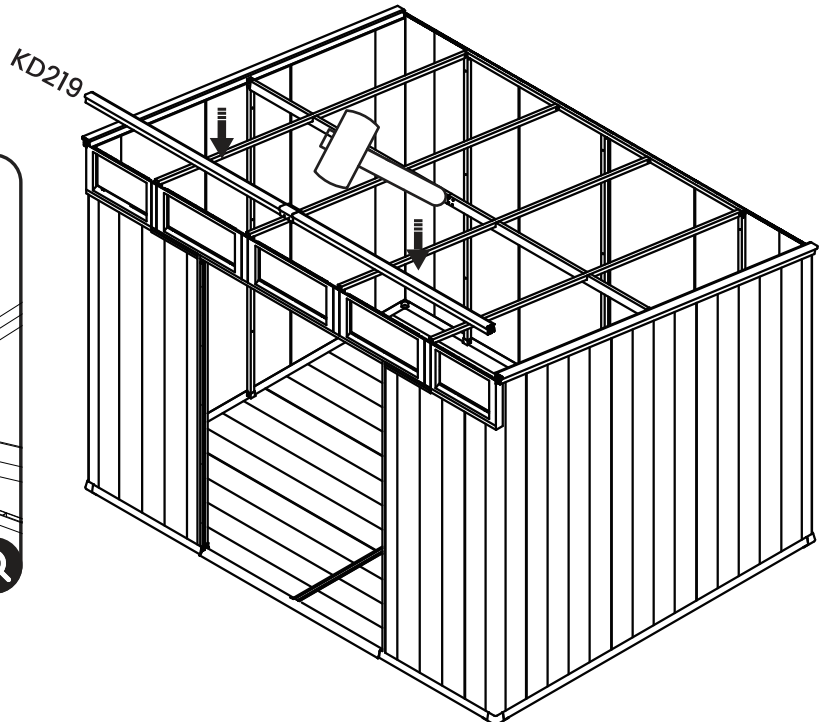
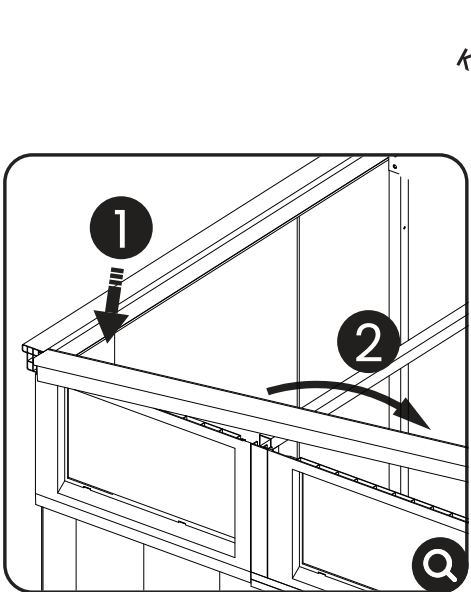
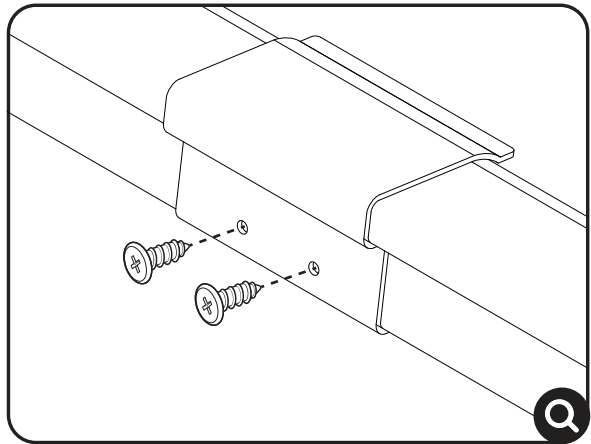
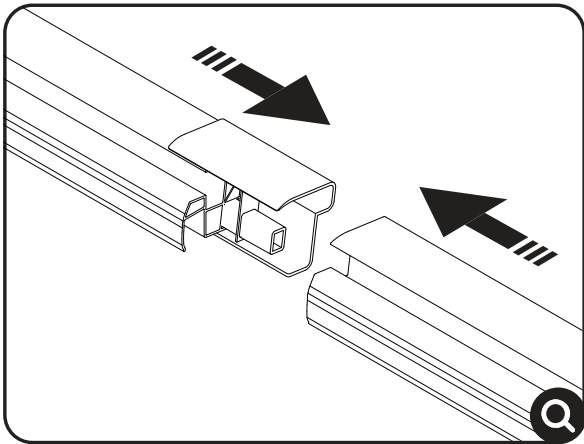
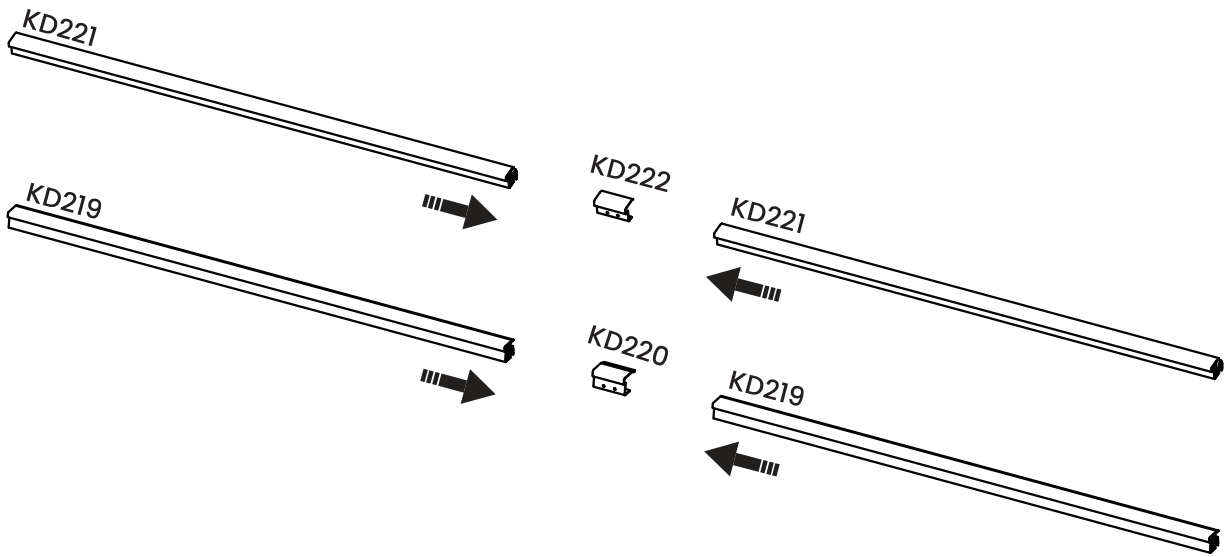

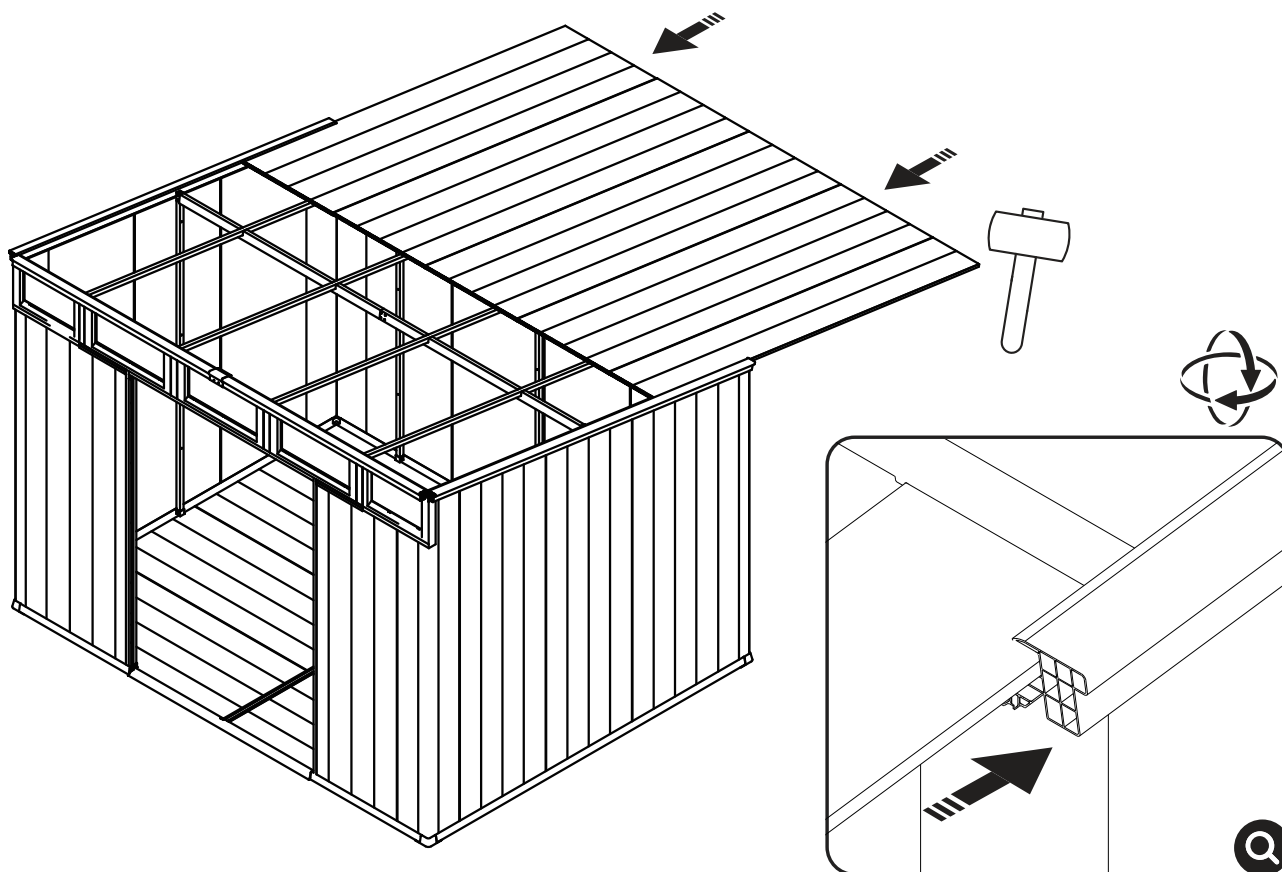

**Pousser le panneau mural jusqu'au bout avant de le verrouiller.**  
Push the wall panel to the end before locking.

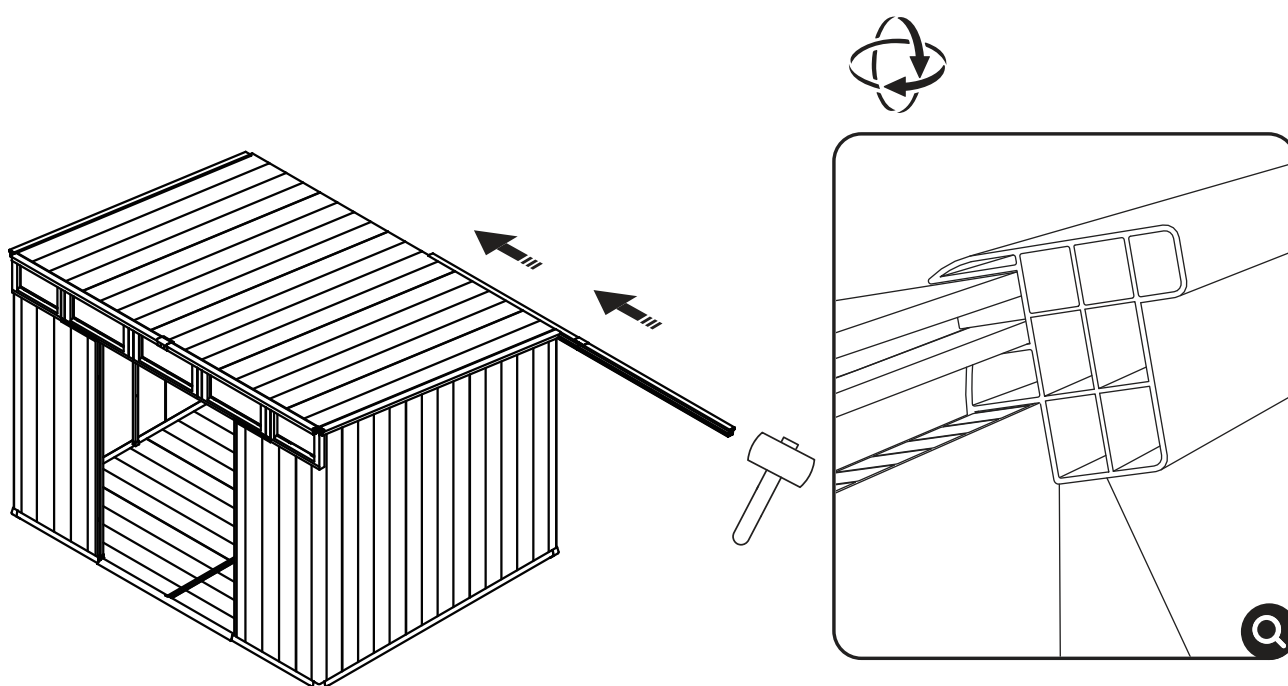

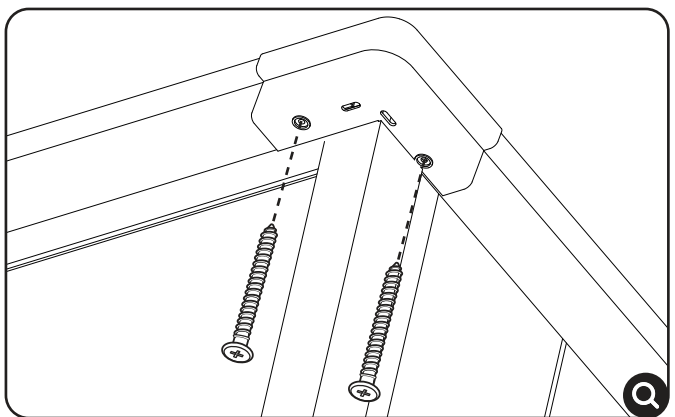
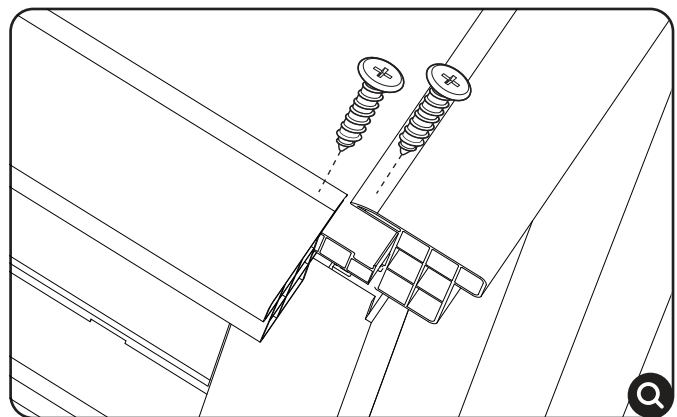
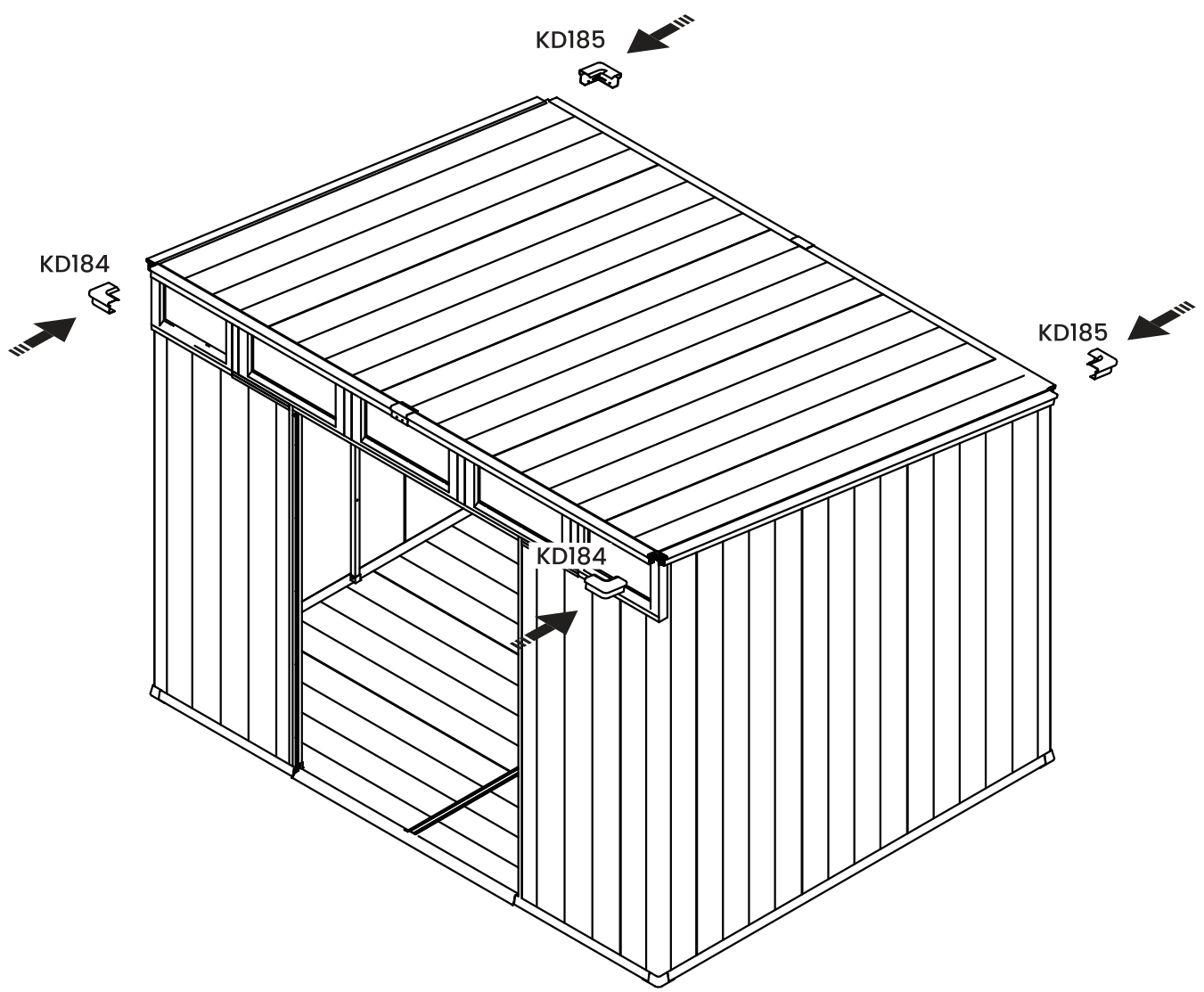

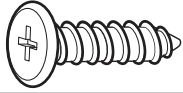

KD084

x4

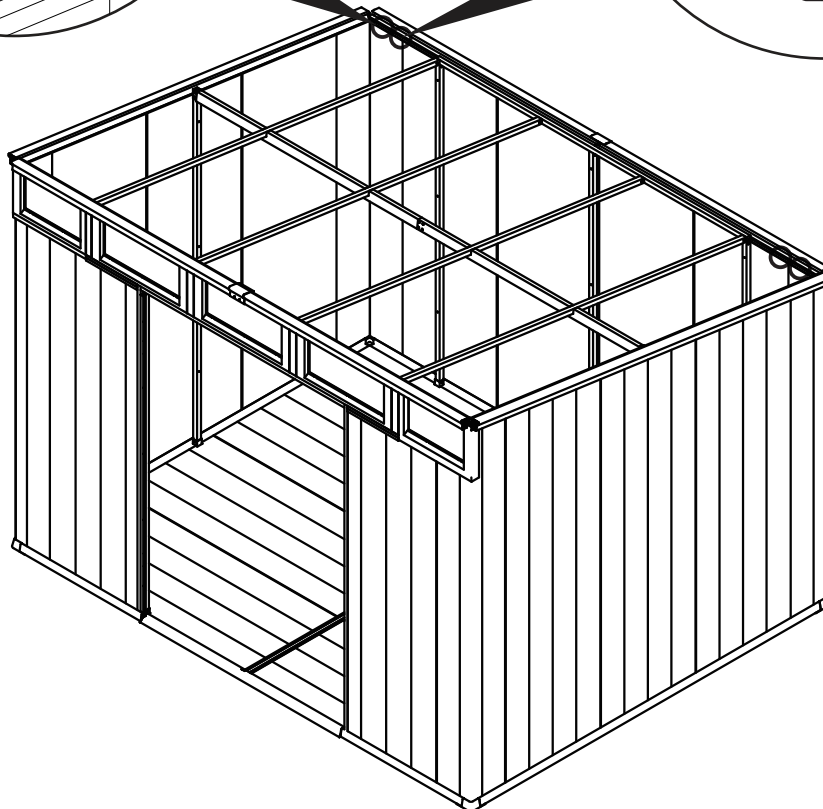
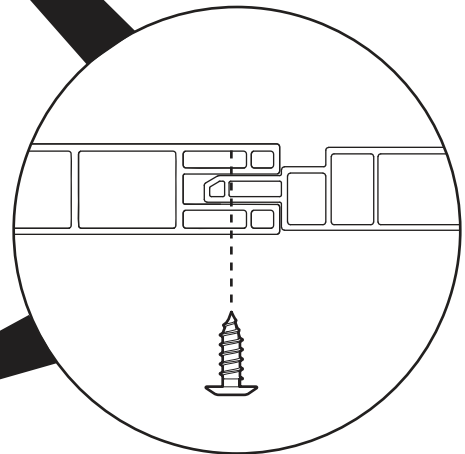
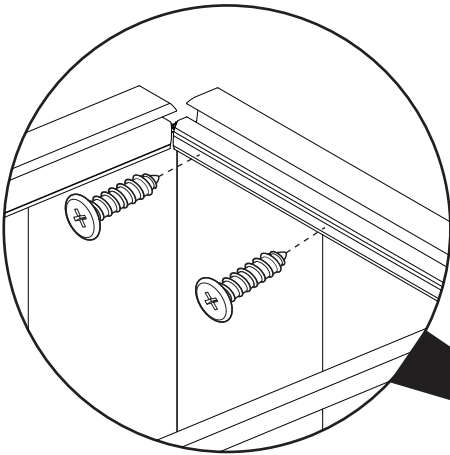
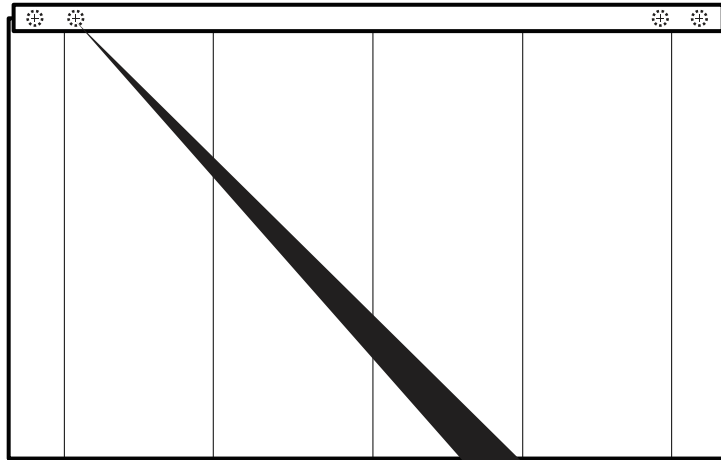



# Fixation intégrale

## Whole Fixation

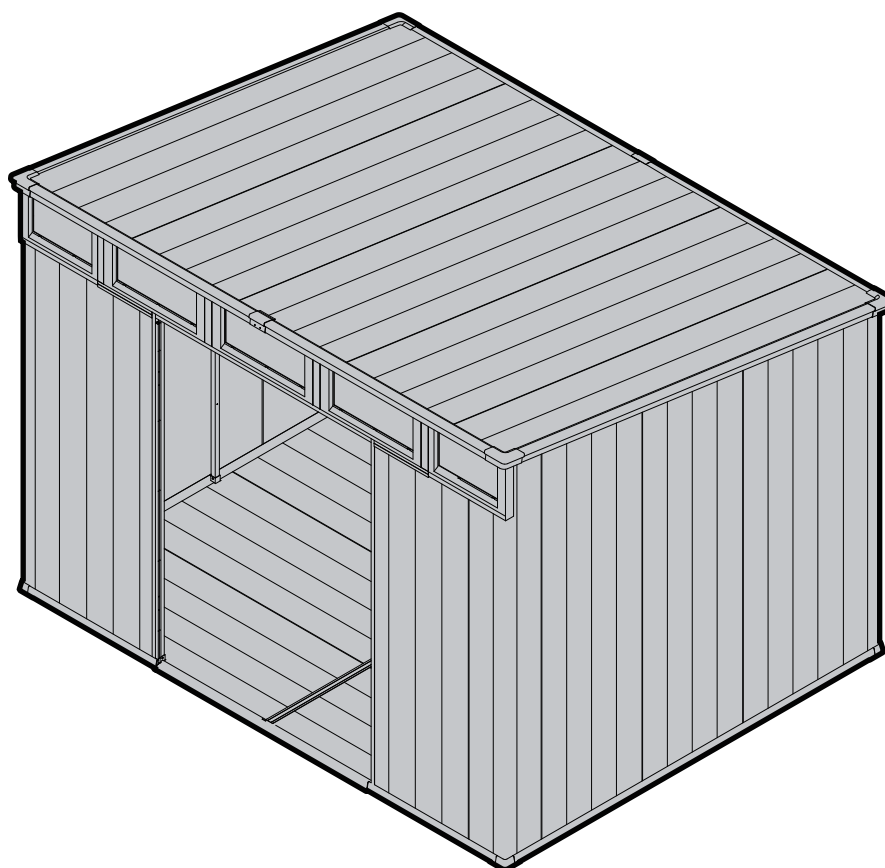



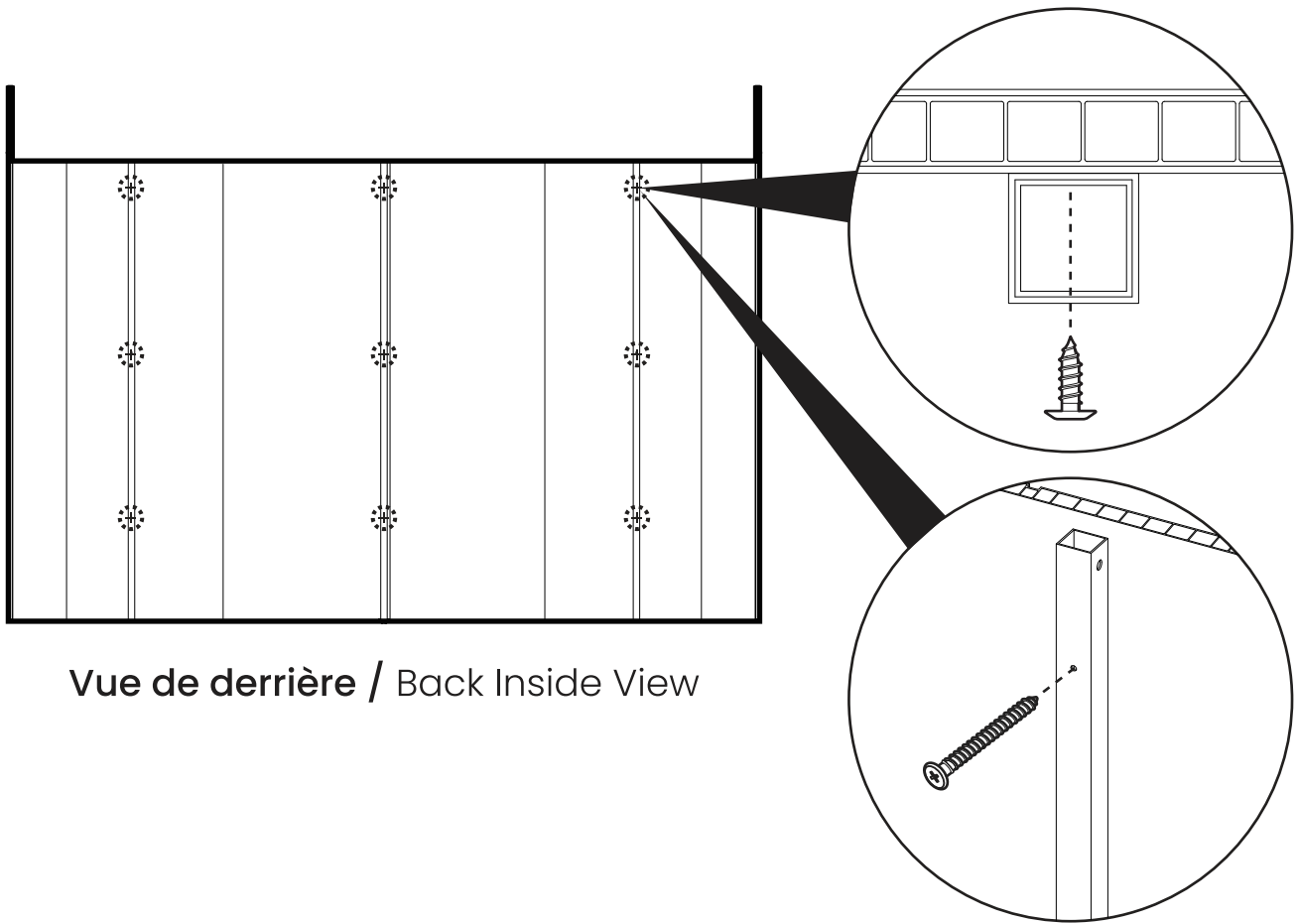

**Vue de derrière / Back Inside View**

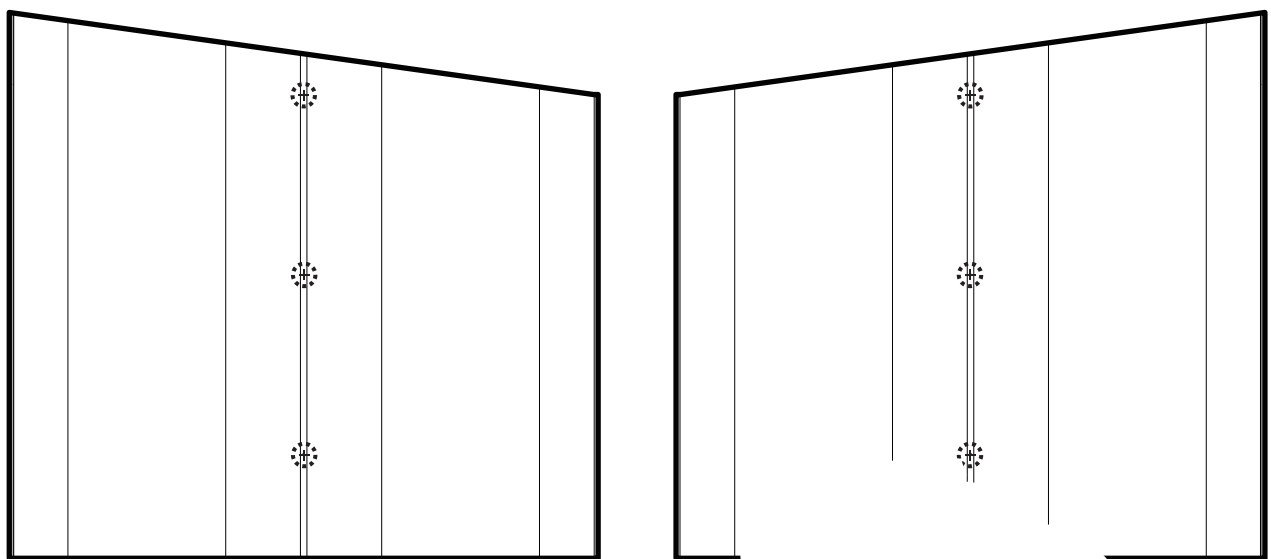

**Vue intérieur gauche**  
Left Inside View

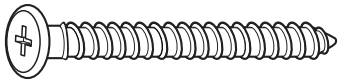

KD085

x9

Vis à l'intérieur / Screw Inside

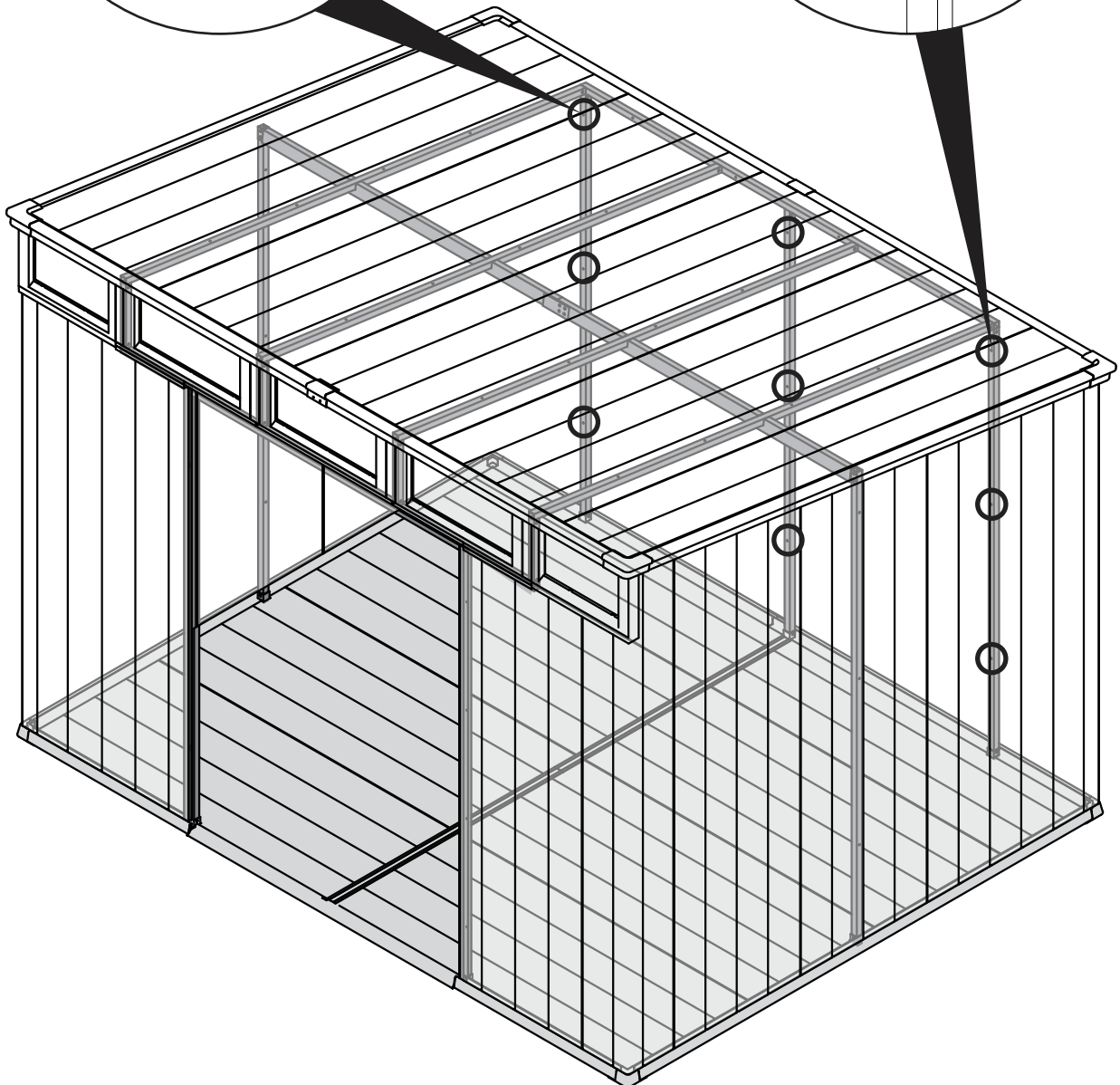
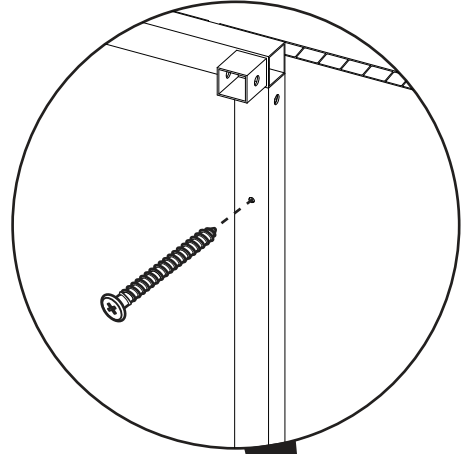
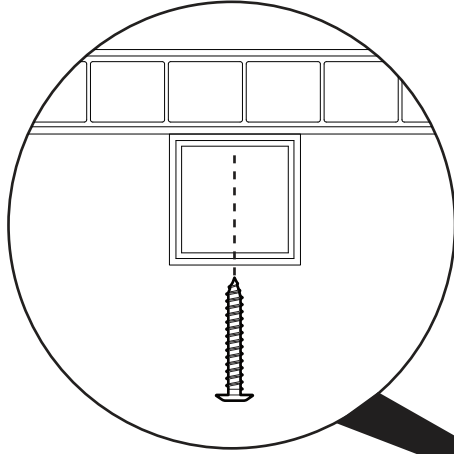

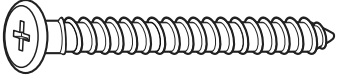

KD085

x6

Vis à l'intérieur / Screw Inside

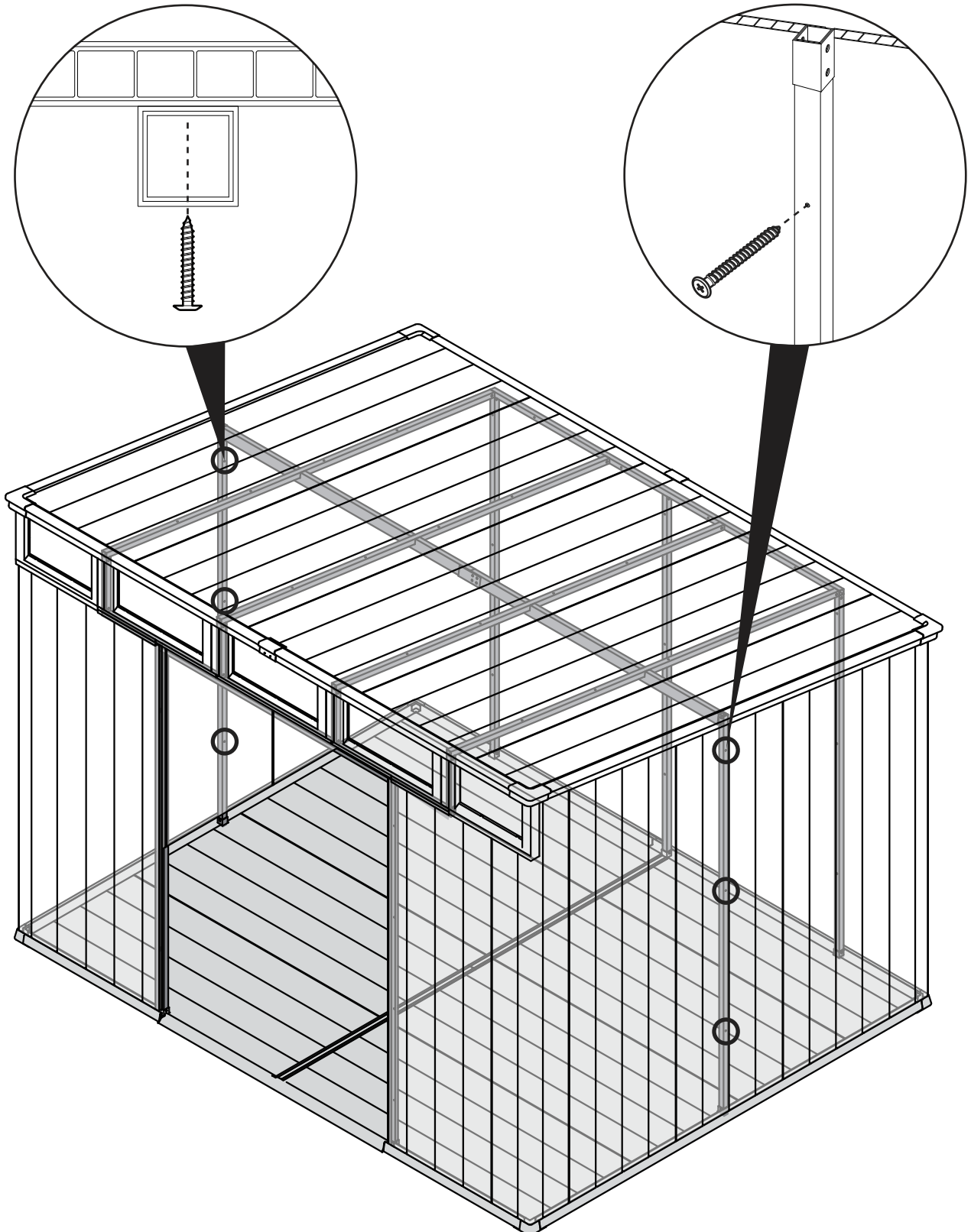

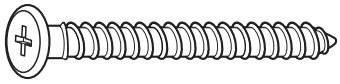

KD085

x4

Vis à l'intérieur / Screw Inside

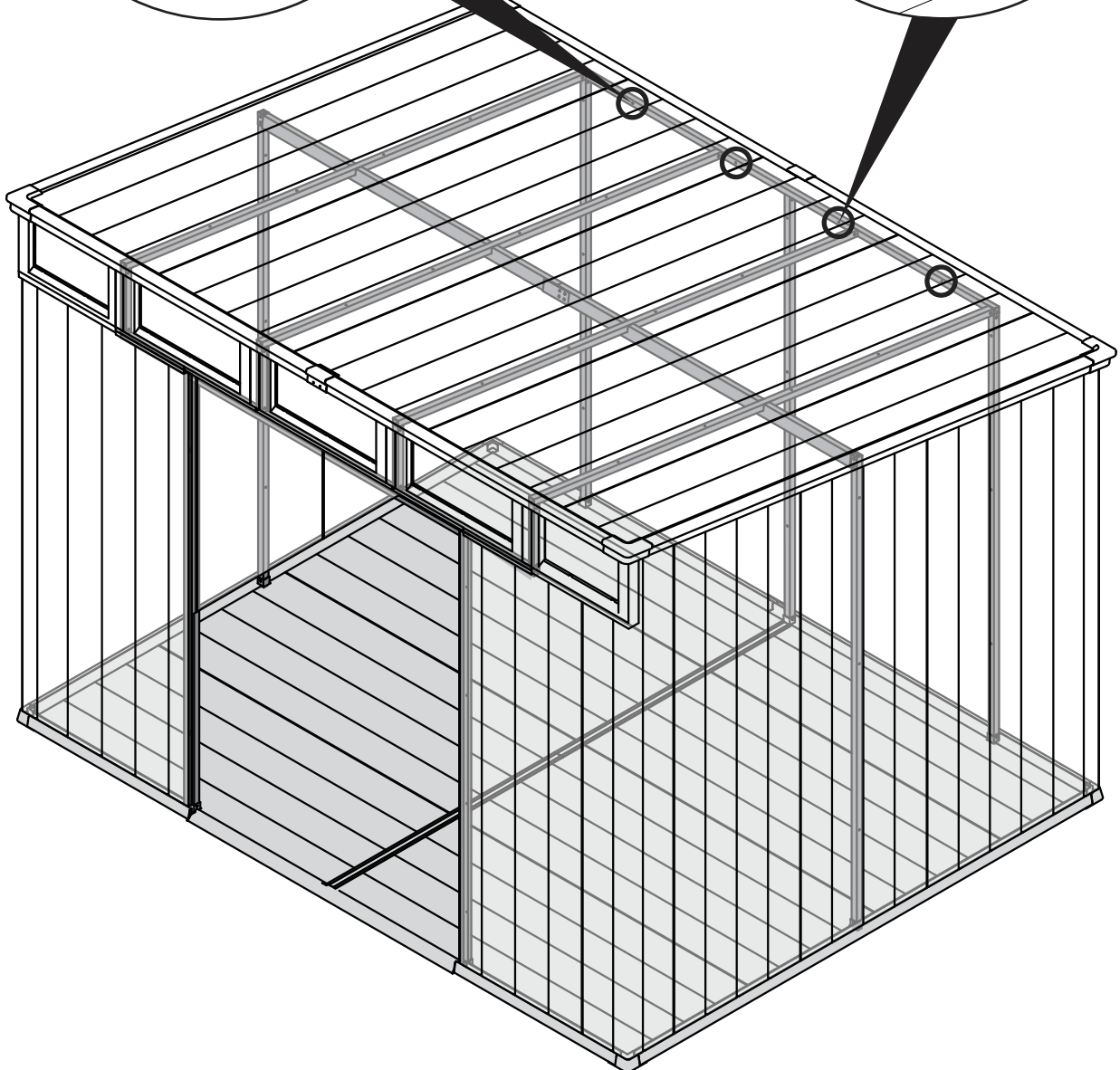
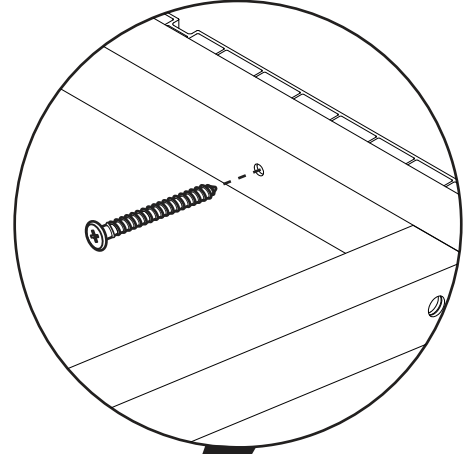
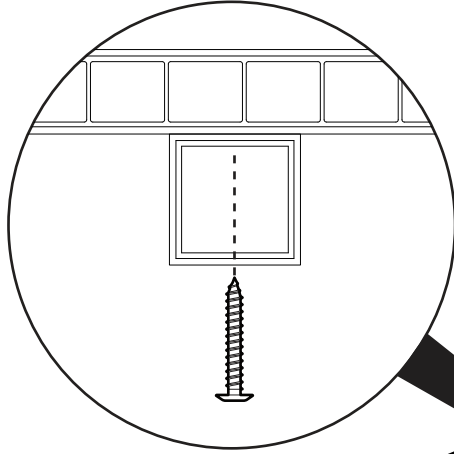

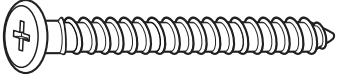

KD085

x16

Vis à l'intérieur / Screw Inside

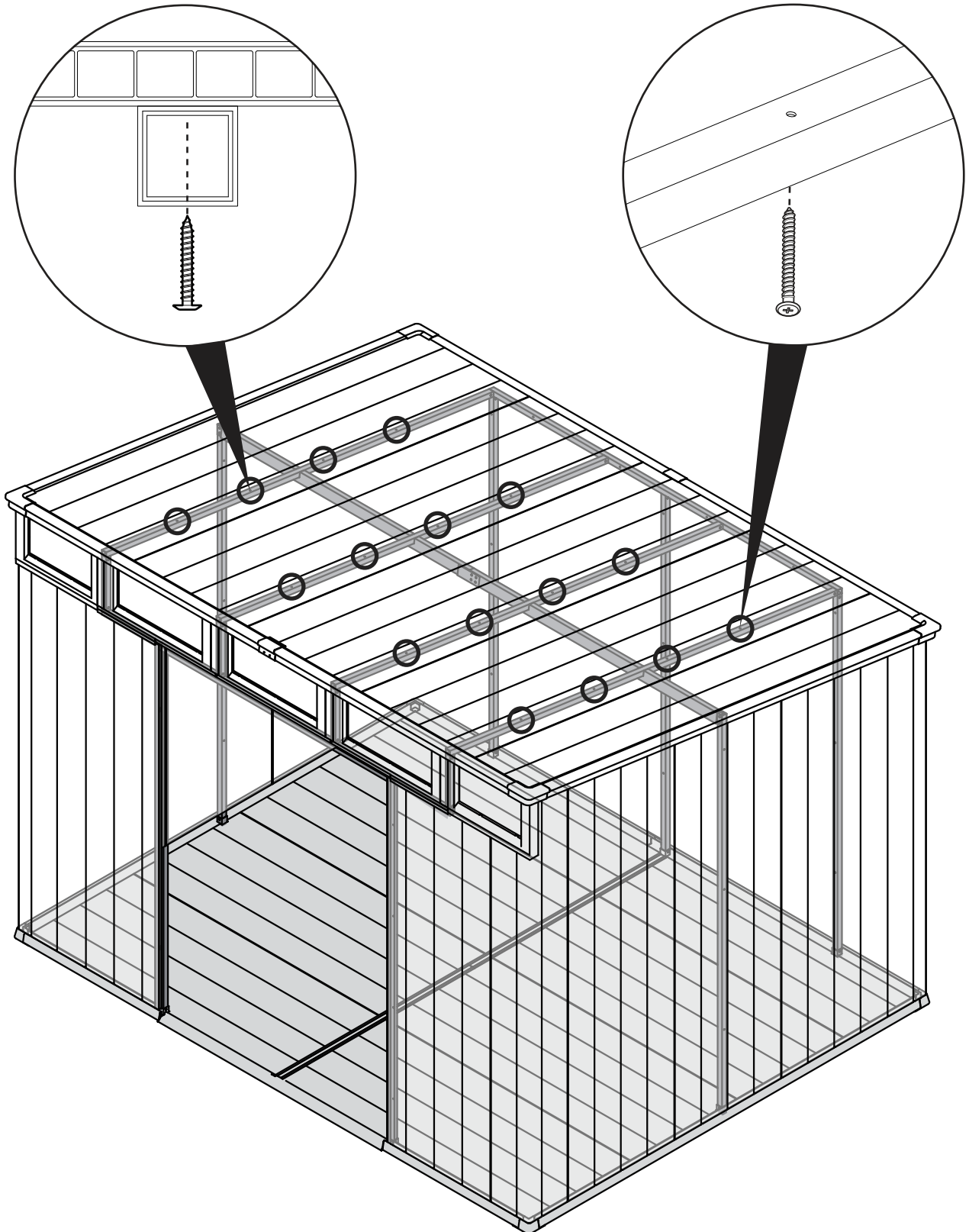





# Assemblage de porte

## Door Assembly

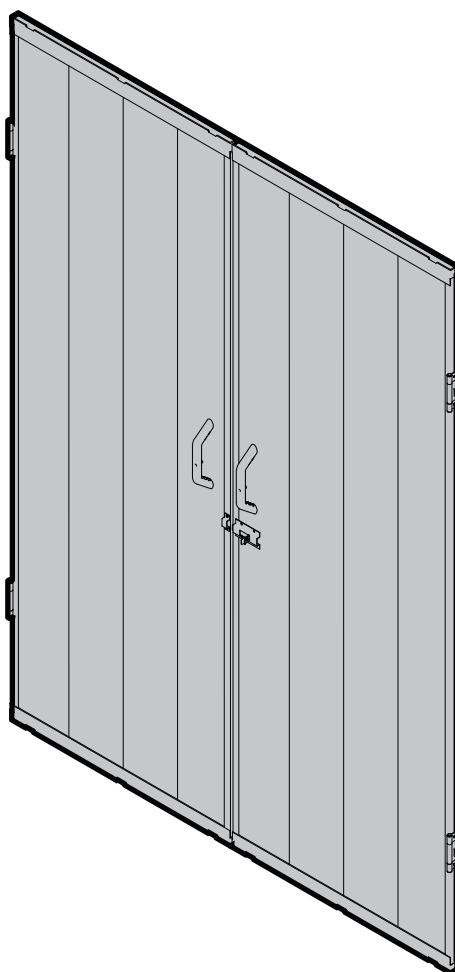

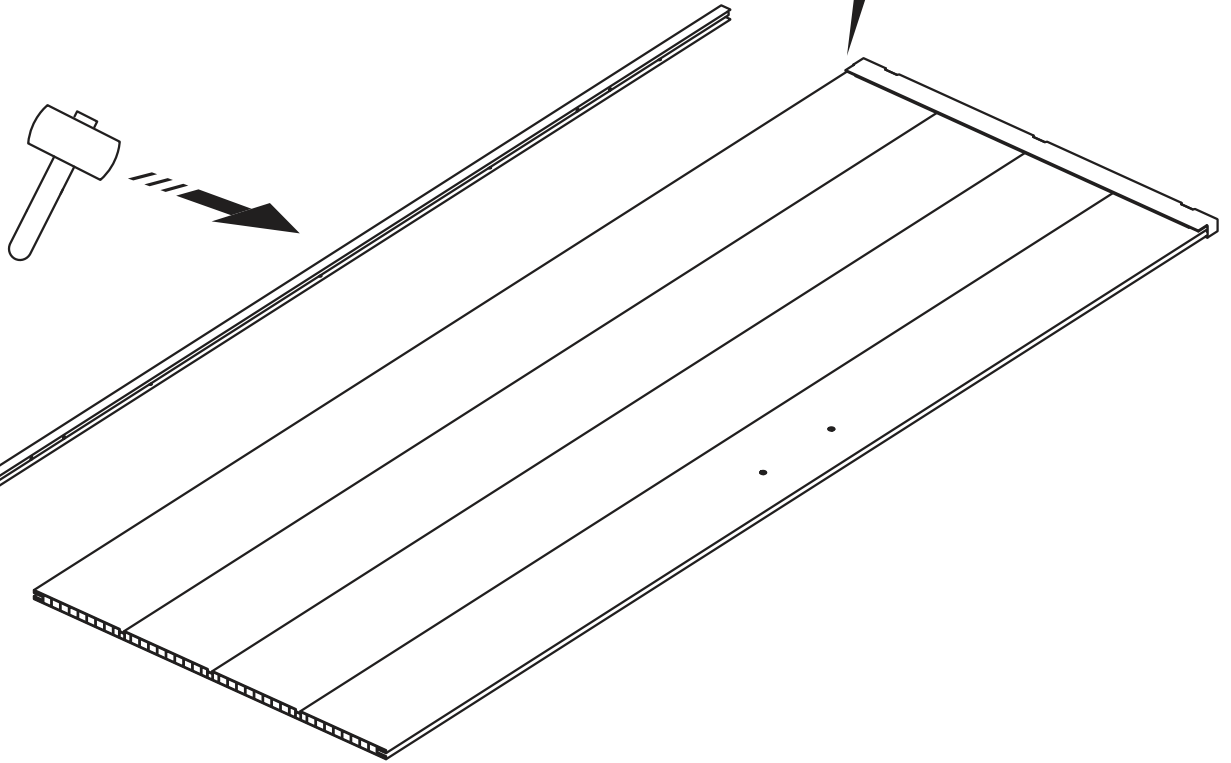
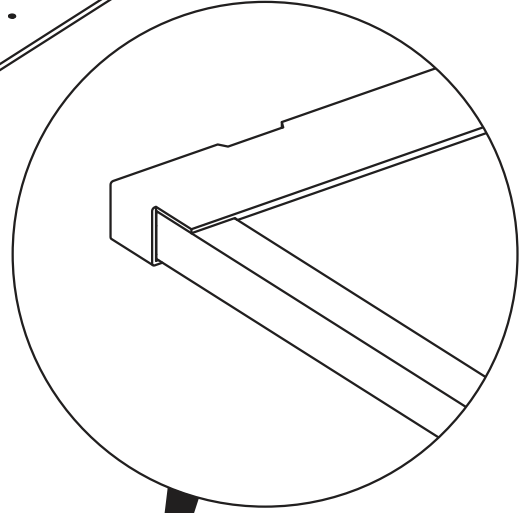
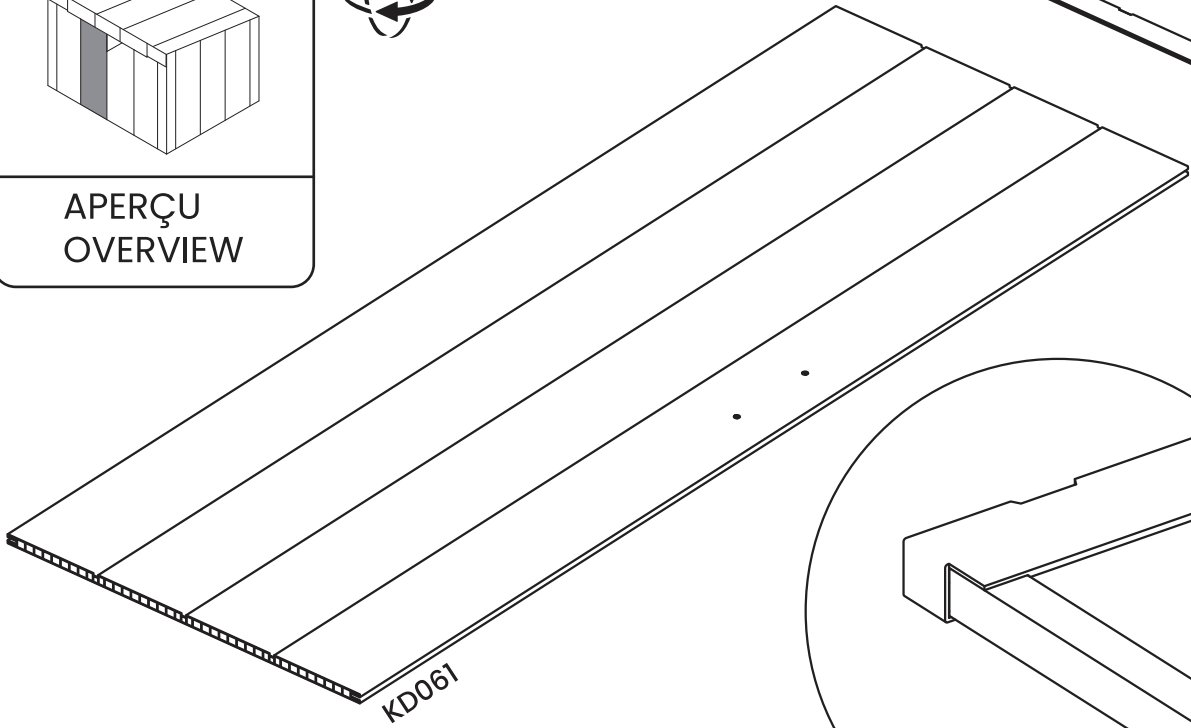
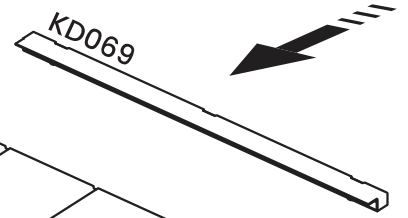
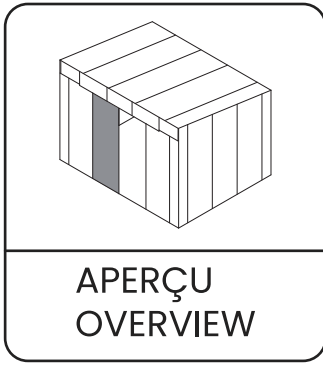

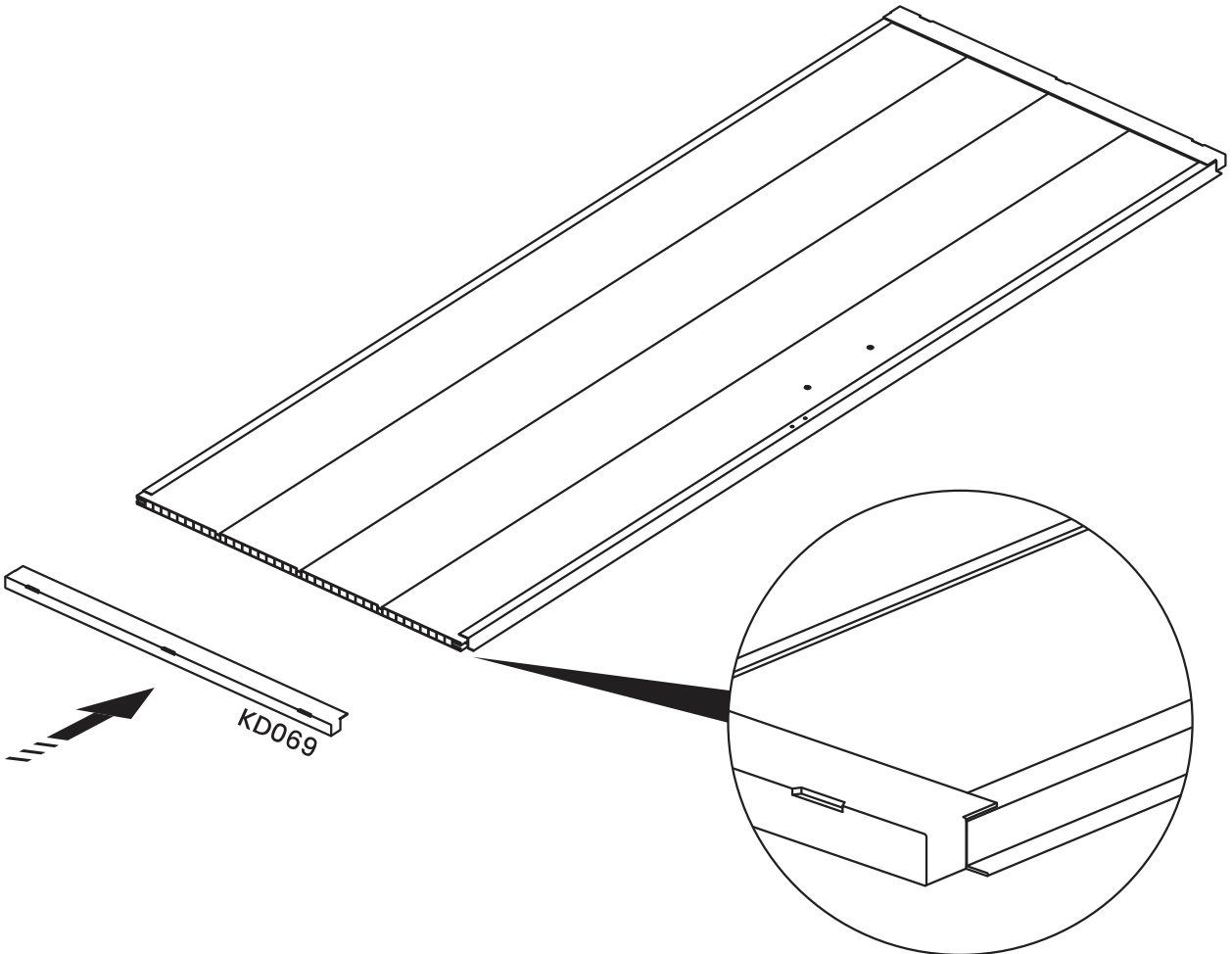
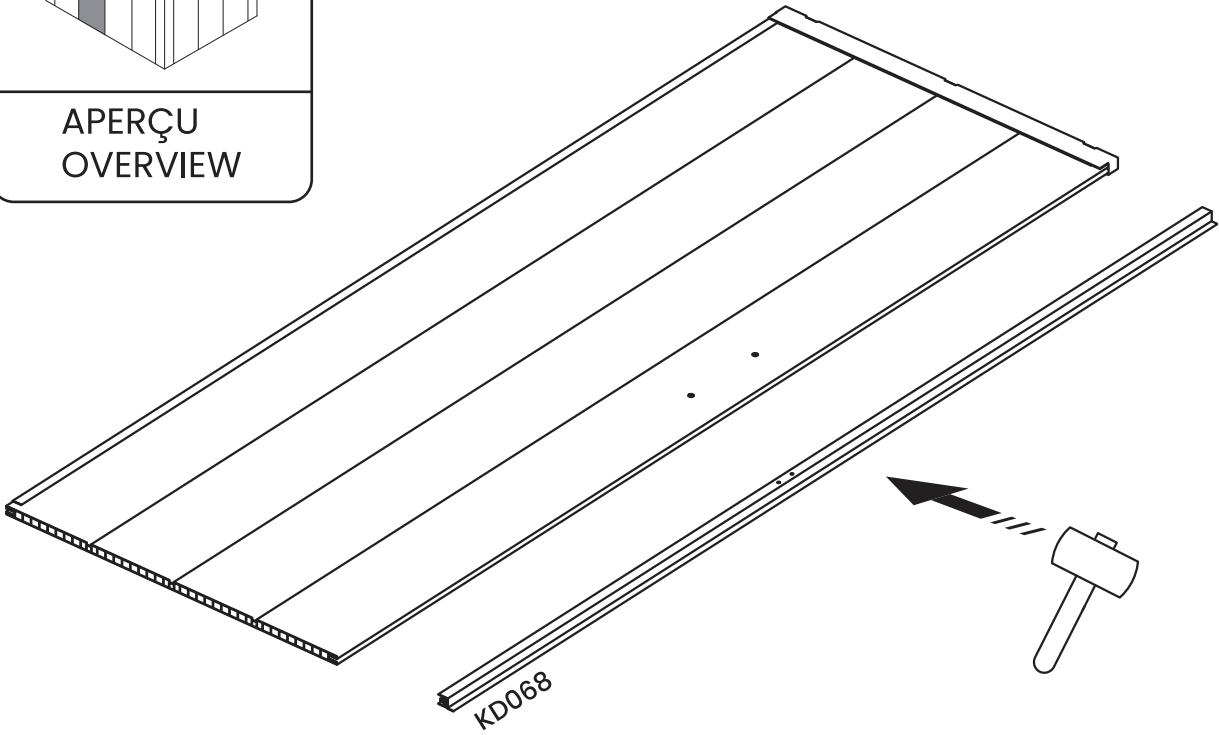
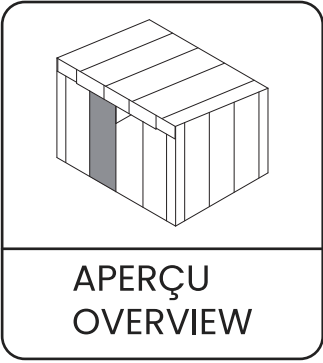

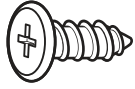

KD083

x14

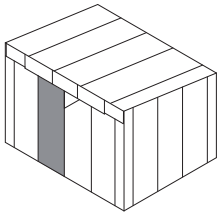

APERÇU  
OVERVIEW

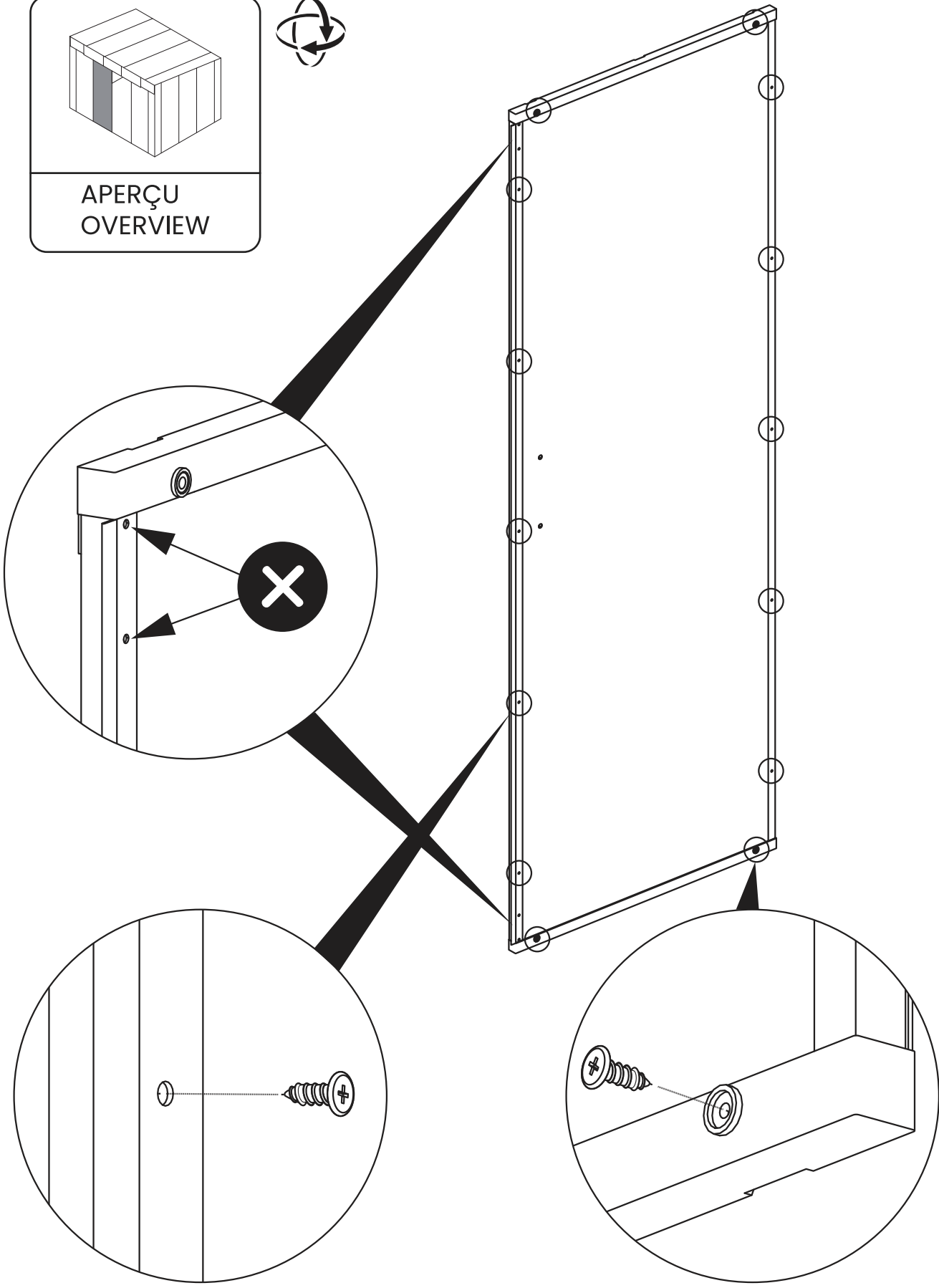

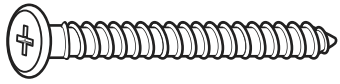

KD085

x4

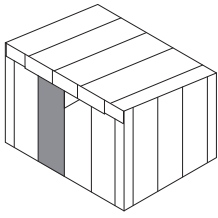

APERÇU  
OVERVIEW

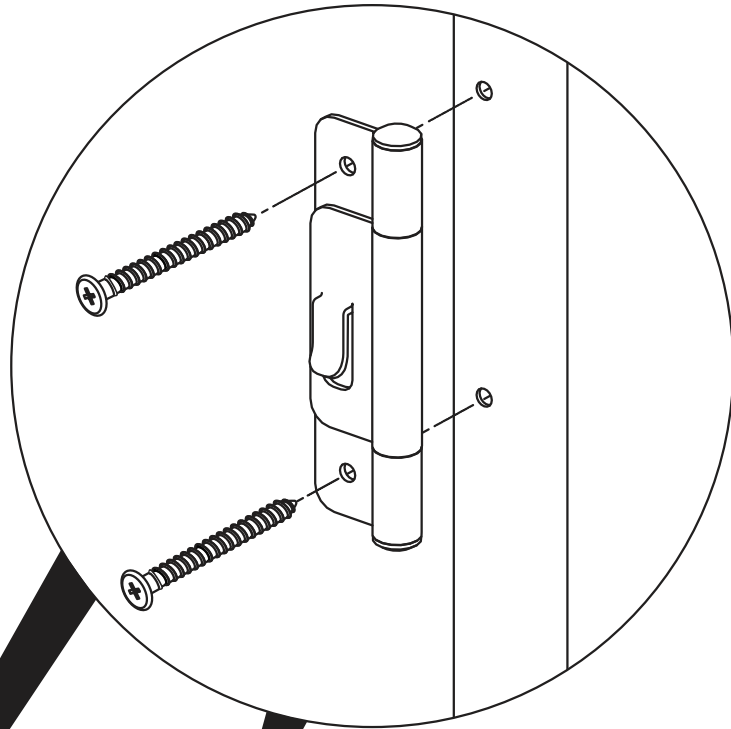

KD072



KD072

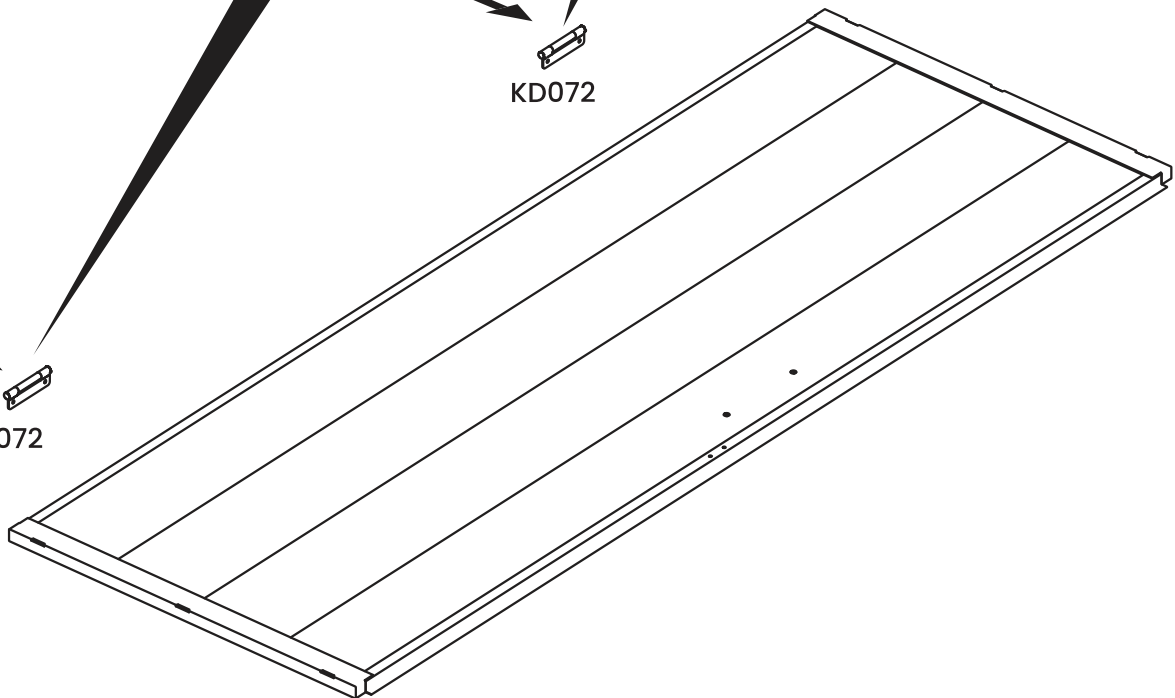

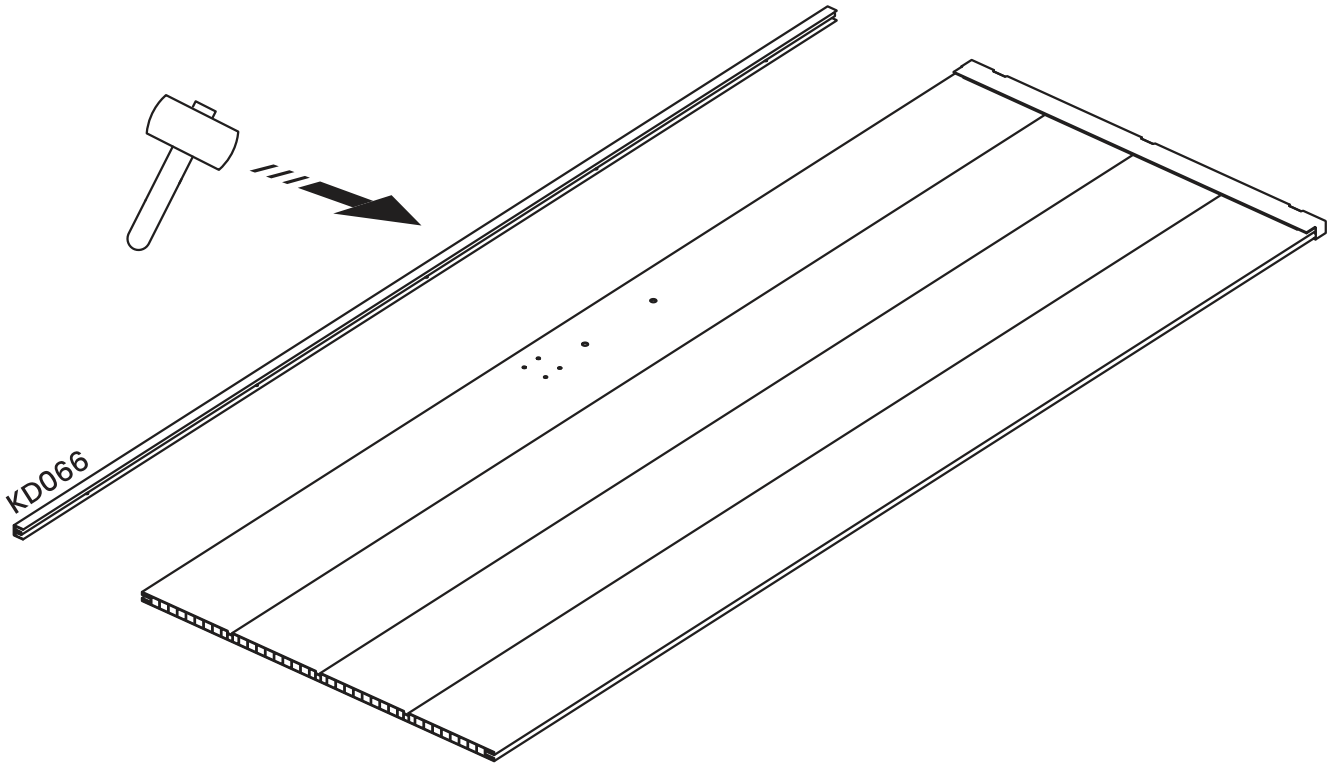
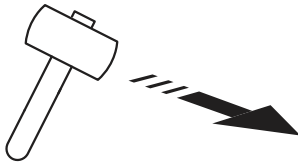
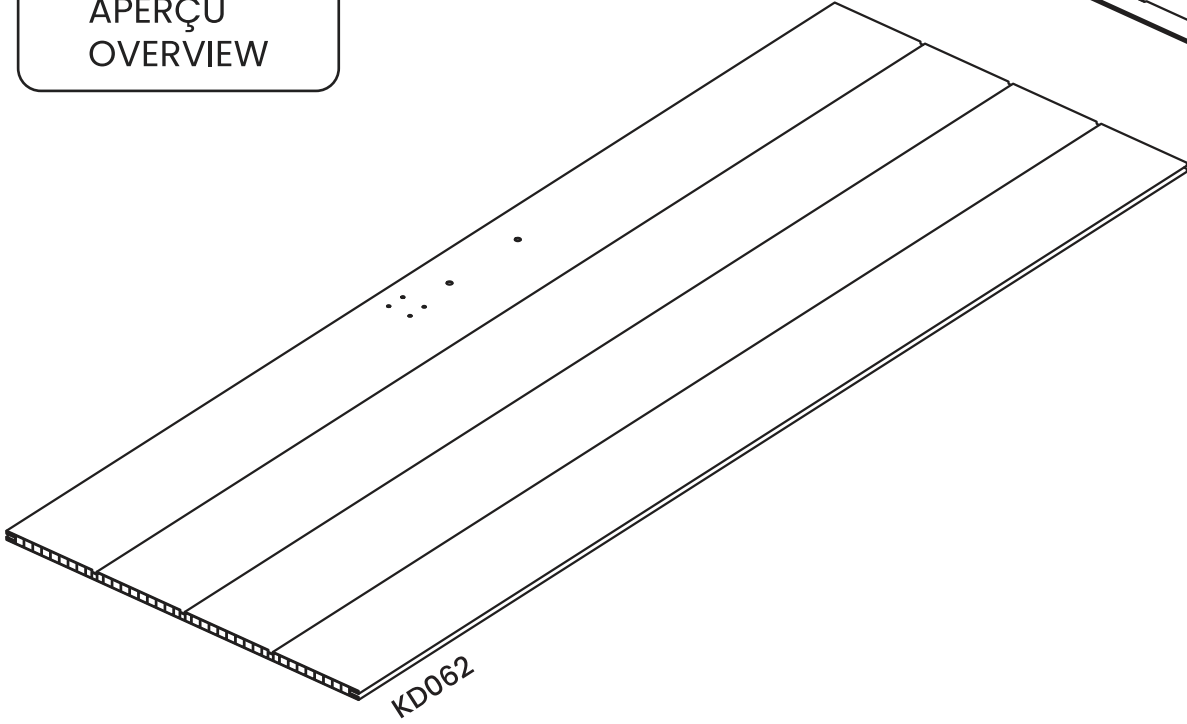
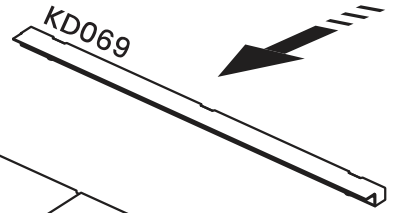
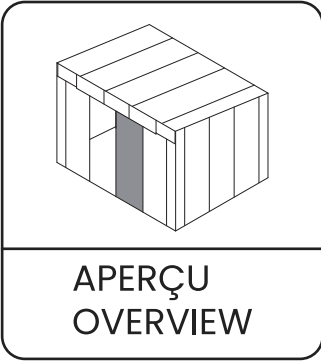

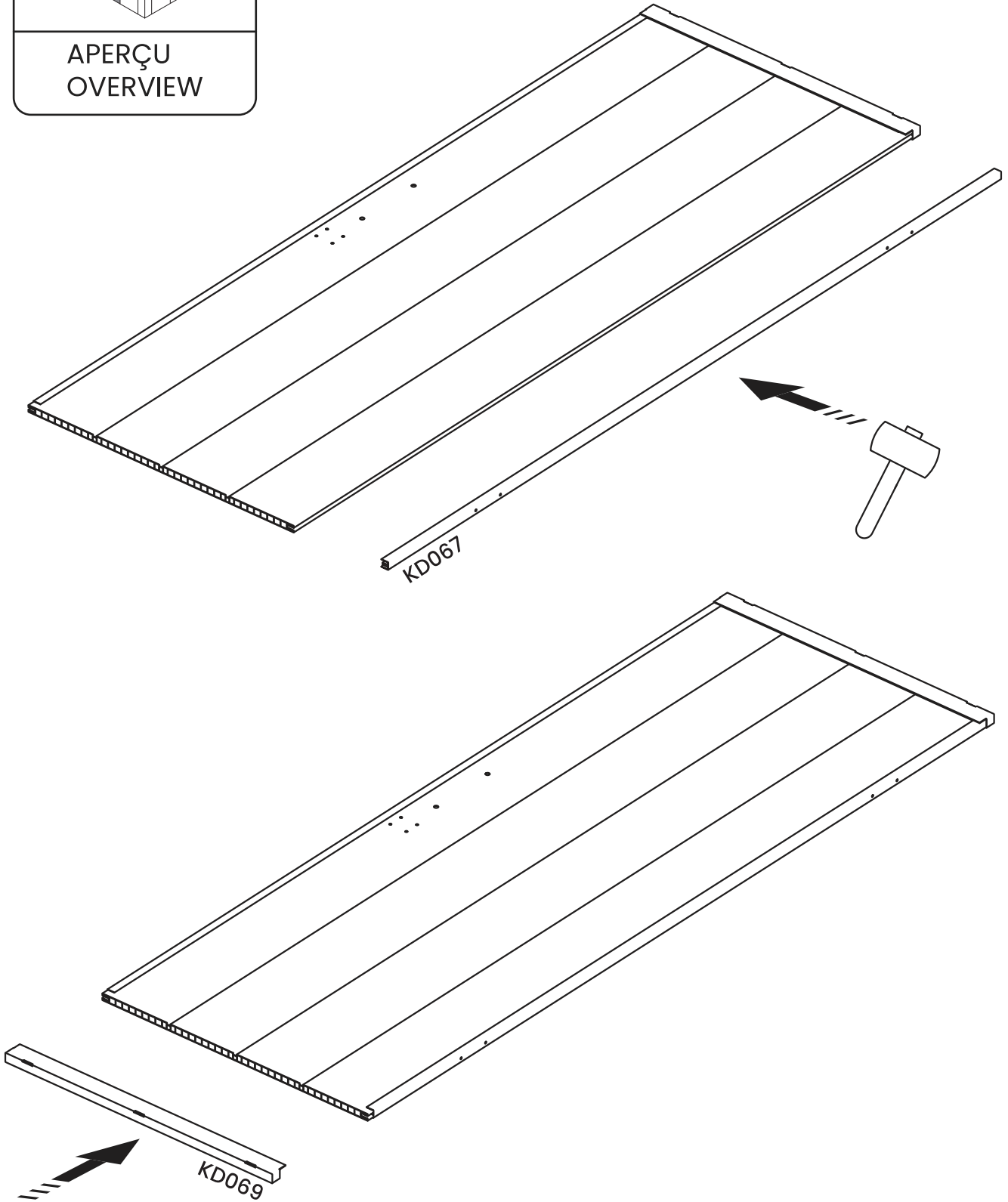
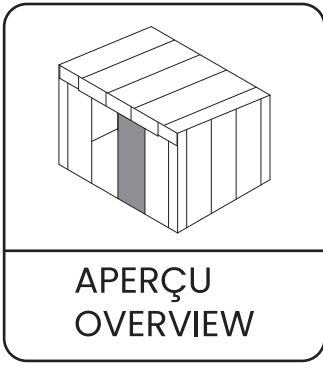

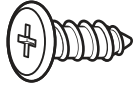

KD083

x14

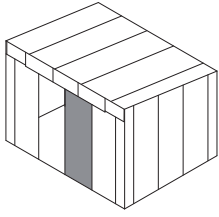

APERÇU  
OVERVIEW

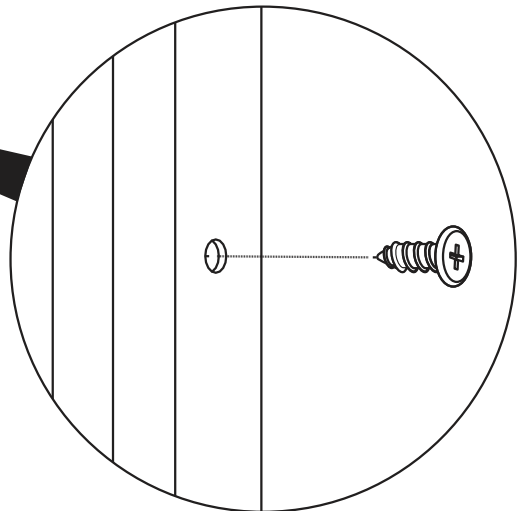
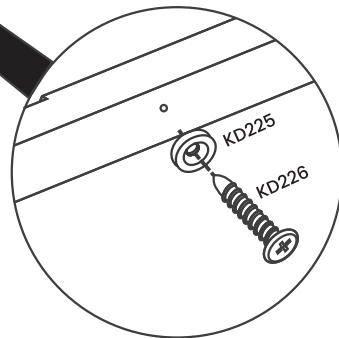
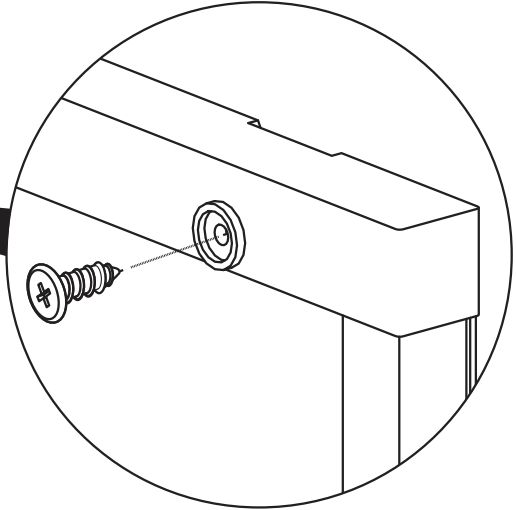
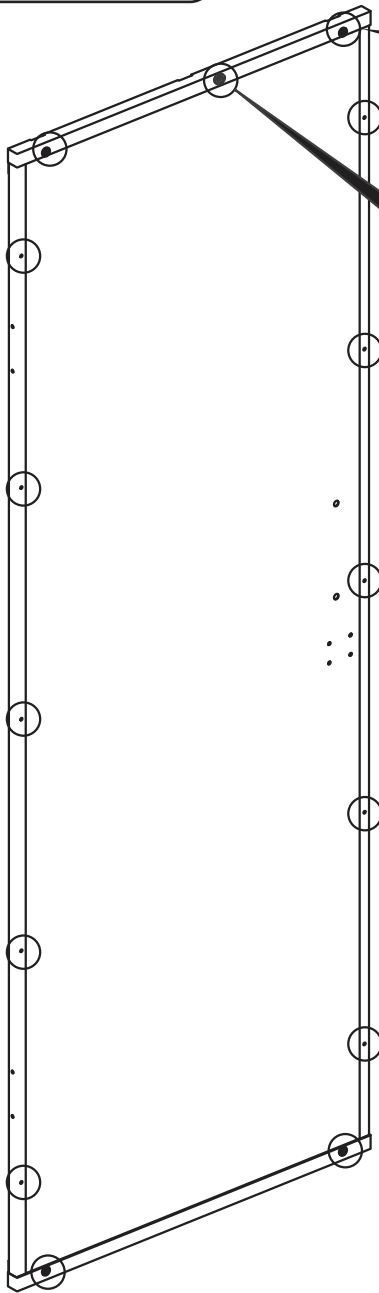



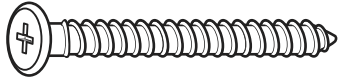

KD085

x4

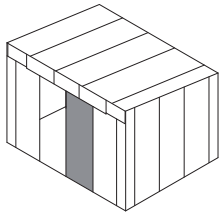

APERÇU  
OVERVIEW

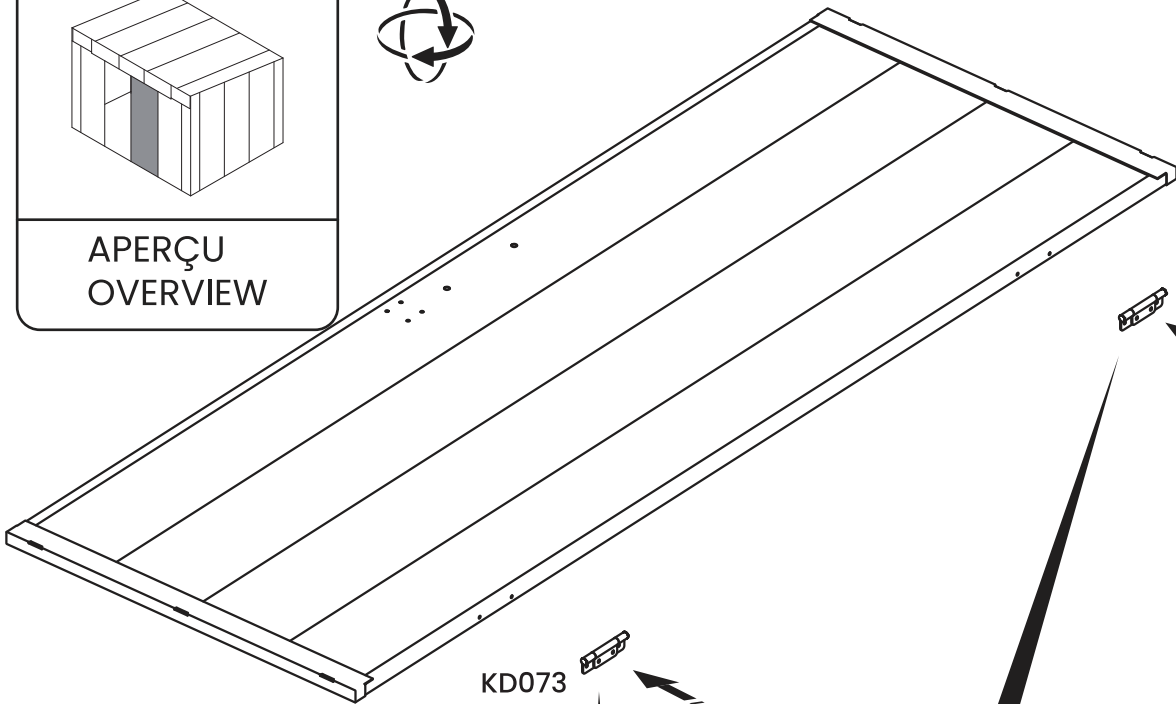

KD073

KD073

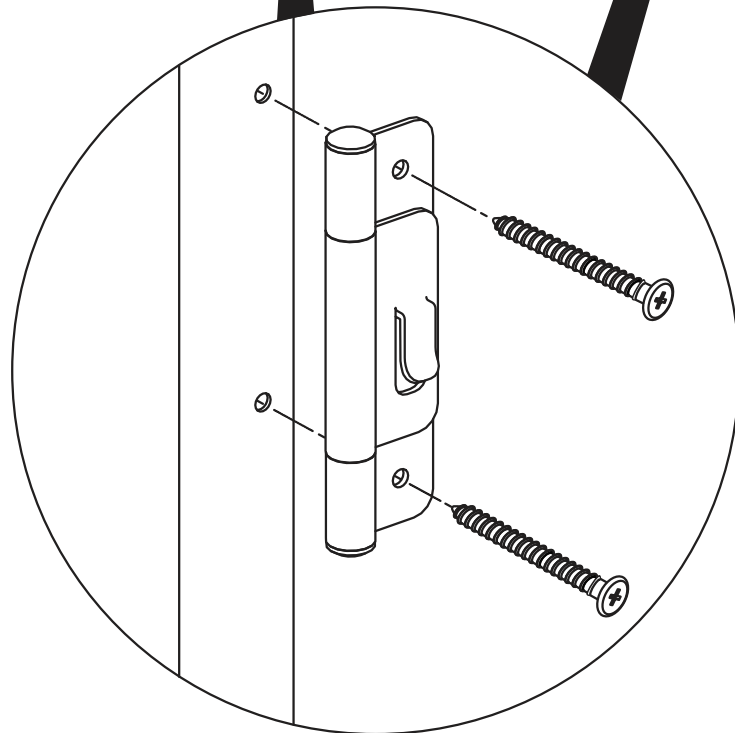

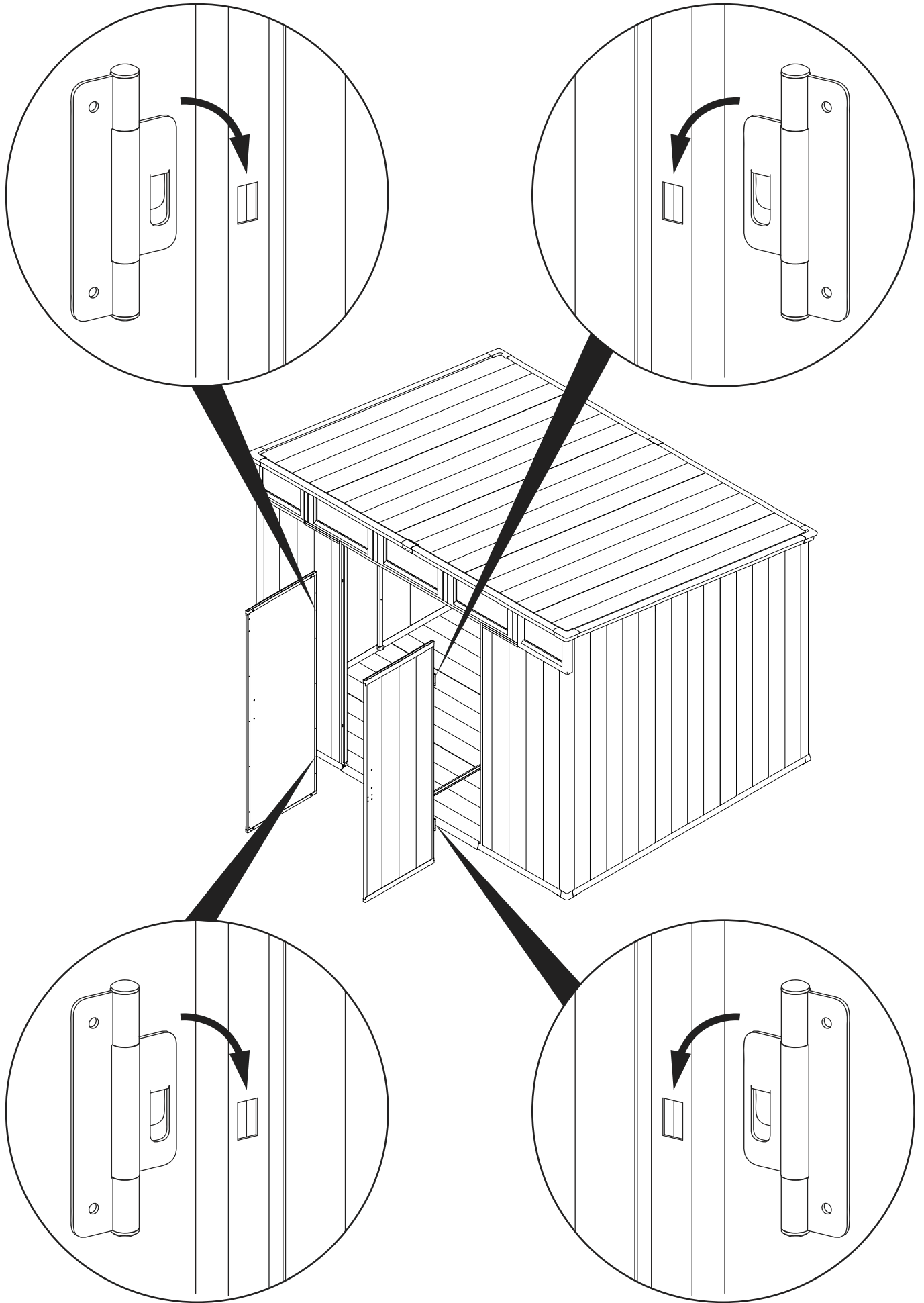

KD070 x2 KD071 x2 KD084 x4

KD079 x2 KD084 x4

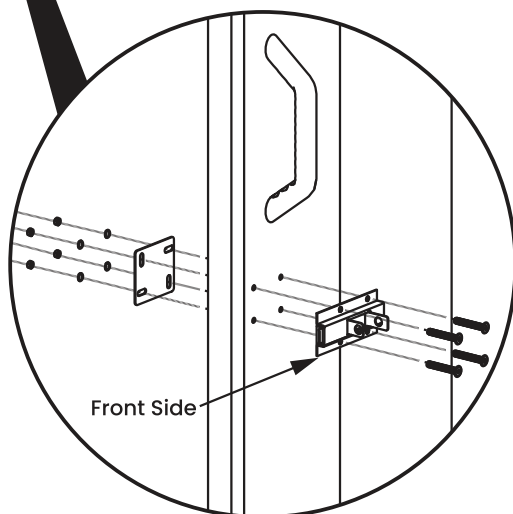
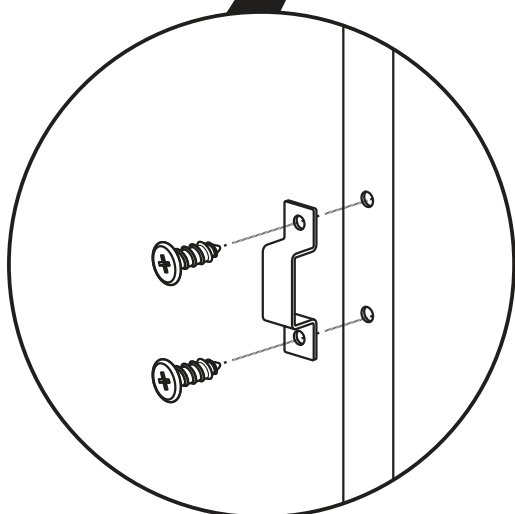
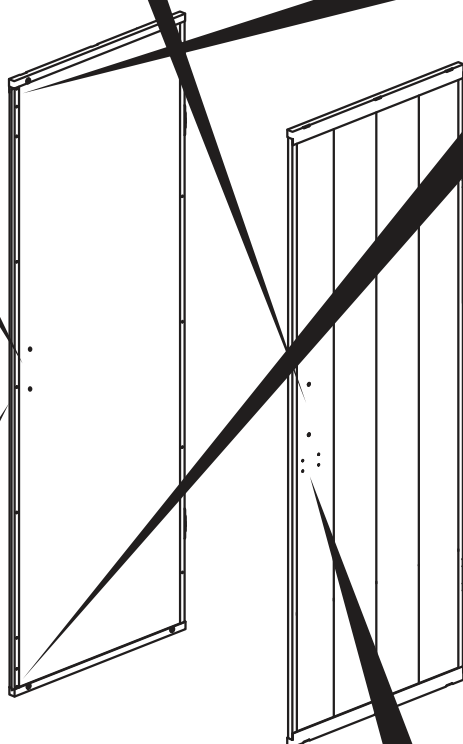
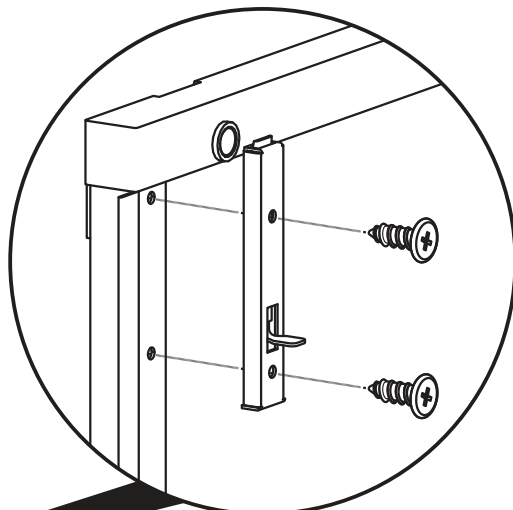
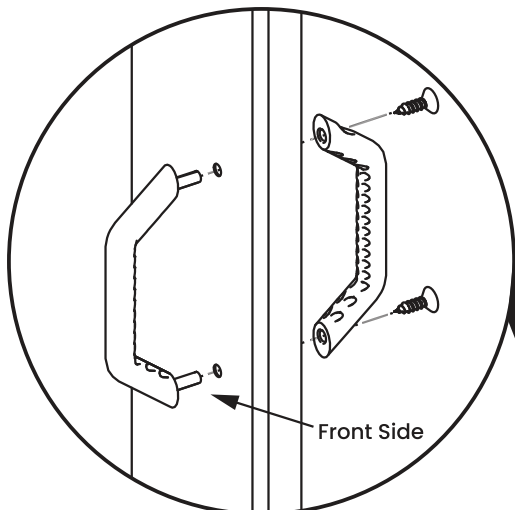

KD076 x1 KD083 x2

KD075 KD077 KD078 x4



# Schémas de sécurité / Security Schemes

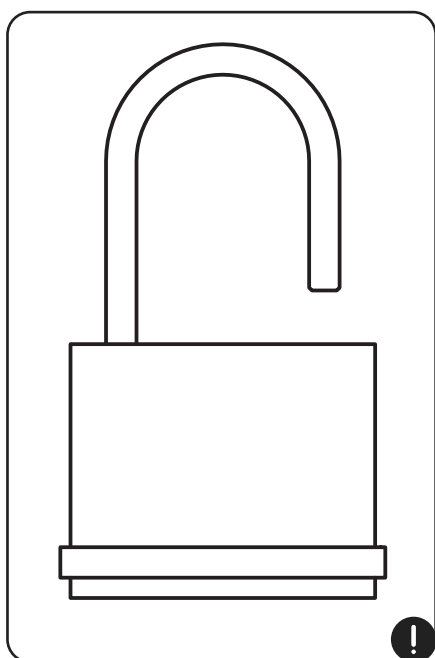
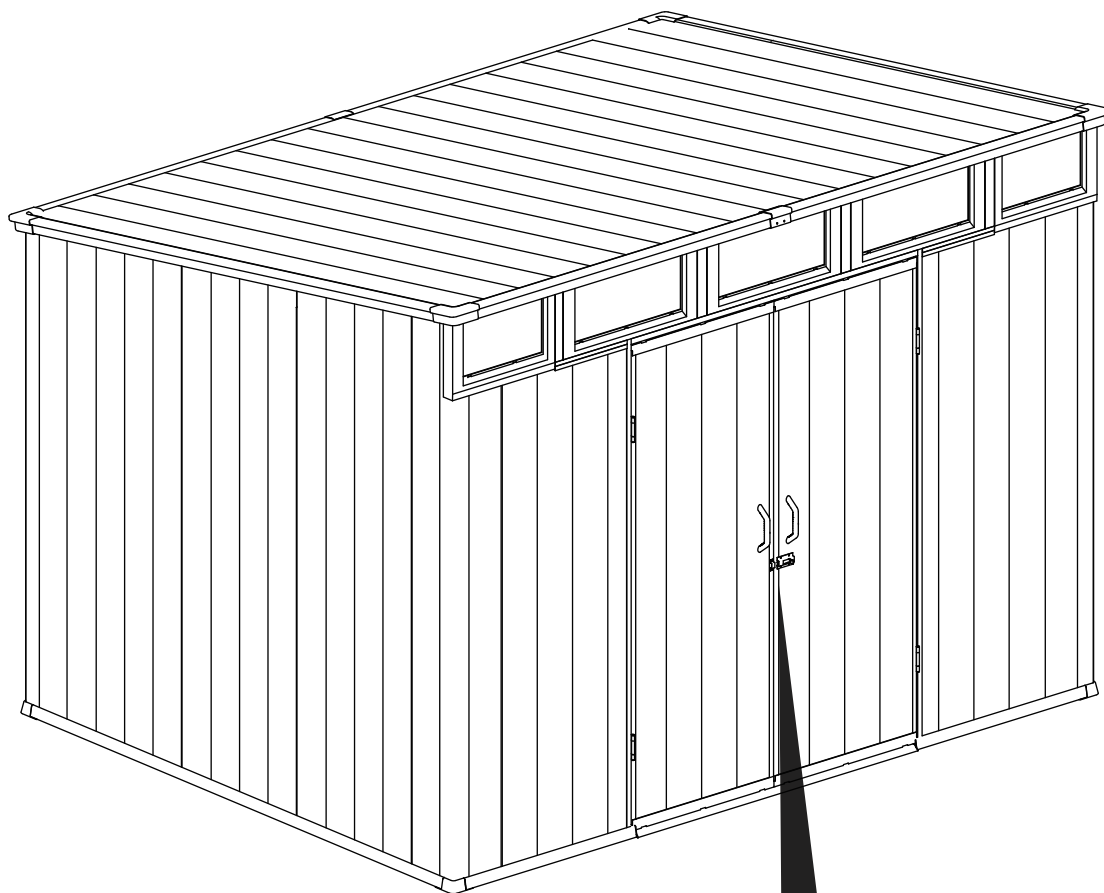

**Non inclus**  
Not included

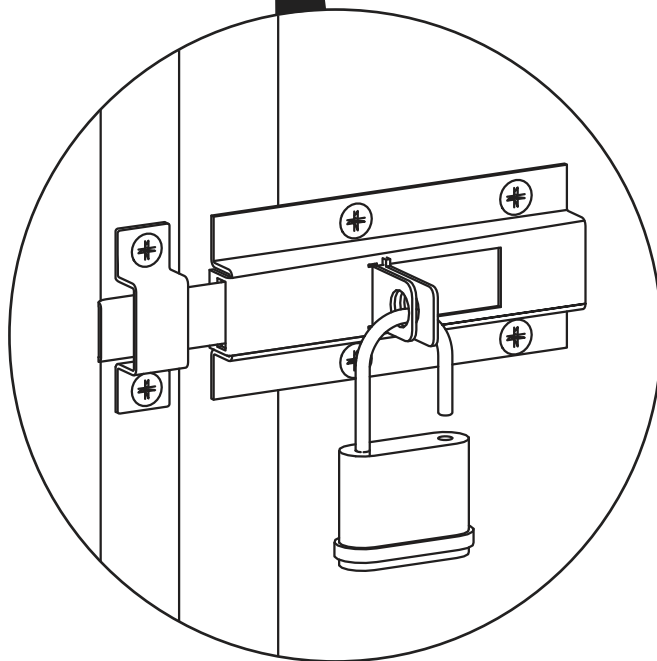





# Directives et garantie

## Guidelines & Warranty





## Conception sans entretien / Maintenance-Free Design

**Le cabanon est construit avec un matériau sans entretien qui élimine le besoin de peinture ou de vernis. Bien que les murs puissent être peints pour les personnaliser, aucun traitement supplémentaire n'est nécessaire pour maintenir la durabilité et l'apparence de l'abri.**

The Shed is built with a maintenance-free material that eliminates the need for paint or varnish. While the walls can be painted for customization, no additional treatments are required to maintain the shed's durability and appearance.

## Murs à peindre uniques / Unique Paintable Walls

**Le cabanon est fabriqué à partir d'un composé unique sans entretien qui permet de peindre les panneaux muraux brossés, ce qui vous donne la possibilité de garder l'abri dans sa couleur d'origine ou de le personnaliser pour l'assortir à votre paysage, à votre terrasse, à votre patio ou à d'autres aménagements extérieurs.**

The Shed is crafted from a maintenance-free, unique compound that allows the brushed wall panels to be painted, giving you the option to keep the shed in its original color or to customize it to match your landscape, deck, patio, or other outdoor settings.

## Instructions pour la peinture / Painting Instructions

**\*\*Type de peinture\*\* : Utiliser une peinture acrylique à base d'eau pour les applications extérieures. Il est recommandé d'utiliser des teintes claires et solides avec une finition satinée ou semi-brillante. Consulter un spécialiste des couleurs ou un professionnel de la peinture pour obtenir de l'aide dans le choix de la peinture.**

**\*\*Application\*\* : Appliquer la peinture au rouleau sur la surface du mur sec. Éviter de peindre les fissures des panneaux muraux qui ressemblent à des poutres.**

**\*\*Zones à éviter\*\* : Ne peignez pas les fenêtres, les portes, la poutre de la porte, le toit, le sol ou toute autre partie du cabanon autre que les murs désignés.**

**\*\*Type of Paint\*\*:** Use water-based acrylic paint for exterior applications. Solid, light shades with a satin or semi-gloss finish are recommended. Consult a color specialist or paint professional for assistance in selecting paint.

**\*\*Application\*\*:** Apply paint with a roller on the dry wall surface. Avoid painting the beam-like crevices within the wall panels.

**\*\*Areas to Avoid\*\*:** Do not paint the windows, doors, door beam, roof, floor, or any part of the shed other than the designated walls.

## Rappel de maintenance / Maintenance Reminder

**La peinture peut nécessiter des retouches périodiques ou être repeinte au fil du temps pour conserver l'aspect du cabanon. Suivez toujours les consignes d'entretien et de sécurité du fabricant de la peinture avant de l'appliquer.**

**En suivant ces instructions, vous pouvez personnaliser votre cabanon pour qu'il s'intègre parfaitement à votre environnement extérieur.**

Painting may require periodic touch-ups or repainting over time to maintain the shed's appearance. Always follow the paint manufacturer's care and safety guidelines before applying.

By following these instructions, you can personalize your Shed to seamlessly integrate with your outdoor environment.

## Lignes directrices pour l'entretien et la sécurité du cabanon / Shed Care and Safety Guidelines

**Le cabanon est conçu uniquement à des fins de stockage et n'est pas destiné à l'habitation. Veuillez respecter les consignes d'entretien et de sécurité suivantes afin de garantir des performances et une sécurité optimales :**

The Shed is designed strictly for storage purposes and is not intended for habitation. Please adhere to the following care and safety guidelines to ensure optimal performance and safety:

### **\*\*Assemblage et stabilité\*\* / \*\*Assembly and Stability\*\***

- **Ancrez le cabanon à un objet fixe ou fixez-le au sol en perçant le sol aux endroits prévus à cet effet et en insérant les vis appropriées.**
- **Évitez de monter l'abri les jours de vent ou de froid.**
- **Inspectez régulièrement le cabanon pour en vérifier la stabilité et vous assurer que le sol reste plat.**
- Anchor the shed to a fixed object or secure it to the ground by drilling at pre-marked locations in the floor and inserting appropriate screws.
- Avoid assembling the shed on windy or cold days.
- Regularly inspect the shed to confirm stability and ensure the ground remains level.

### **\*\*Manipulation et assemblage\*\* / \*\*Handling and Assembly\*\***

- **Soyez prudent avec les pièces à arêtes en acier pour éviter les blessures.**
- **N'utilisez que les outils indiqués dans le manuel lors de l'assemblage ou de la manipulation.**
- **Éloignez les tondeuses à gazon et les faux mécaniques du cabanon afin d'éviter tout dommage accidentel.**
- **Portez des lunettes de sécurité et respectez les instructions du fabricant lorsque vous utilisez des outils électriques.**
- Exercise caution with steel-edged parts to prevent injury.
- Only use the tools listed in the manual during assembly or handling.
- Keep lawnmowers and mechanical scythes away from the shed to avoid accidental damage.
- Wear safety goggles and adhere to manufacturer instructions when operating power tools.

### **\*\*Nettoyage et entretien\*\* / \*\*Cleaning and Maintenance\*\***

- **Nettoyez le cabanon avec un tuyau d'arrosage ou une solution détergente douce. Évitez d'utiliser des brosses dures ou des nettoyants abrasifs, y compris des dégraissants et des produits à base d'huile ou d'acétone, car ils risquent de tacher ou d'endommager le matériau.**
- Clean the shed with a garden hose or a mild detergent solution. Avoid using stiff brushes or abrasive cleaners, including degreasers and oil- or acetone-based products, as they may stain or damage the material.

### **\*\*Précautions de stockage\*\* / \*\*Storage Precautions\*\***

- **Ne stockez pas d'objets chauds, tels que des grils ou des chalumeaux récemment utilisés, et évitez de stocker des produits chimiques volatils.**
- **Ne placez pas d'objets lourds contre les murs, car cela pourrait provoquer des déformations.**
- **Débarrassez le toit de la neige et des feuilles qui s'y sont accumulées afin d'éviter tout dommage et de garantir un accès sûr.**
- Do not store hot items, such as recently used grills or blowtorches, and avoid storing volatile chemicals.
- Refrain from placing heavy objects against the walls, as this could cause distortion.
- Keep the roof clear of accumulated snow and leaves to prevent damage and maintain safe access.

### **\*\*Considérations météorologiques\*\* / \*\*Weather Considerations\*\***

- **Lorsque vous placez le cabanon, tenez compte de la direction du vent pour minimiser l'exposition, en particulier du côté de la porte. Gardez les portes fermées et verrouillées lorsque l'abri n'est pas utilisé afin d'éviter les dommages causés par le vent.**
- **Évitez de vous tenir sur le toit.**
- When positioning the shed, consider wind direction to minimize exposure, particularly on the door side. Keep doors closed and locked when the shed is not in use to prevent wind damage.
- Avoid standing on the roof.

### **\*\*Autorisations\*\* / \*\*Permits\*\***

- **Consultez les autorités locales pour savoir si un permis est nécessaire pour l'installation d'un cabanon dans votre région.**
- Consult with local authorities to determine if permits are required for shed installation in your area.

**En suivant ces directives, vous contribuerez à faire de votre abri de jardin une solution de stockage sûre et fonctionnelle.**

By following these guidelines, you'll help ensure that your Shed remains a safe and functional storage solution.



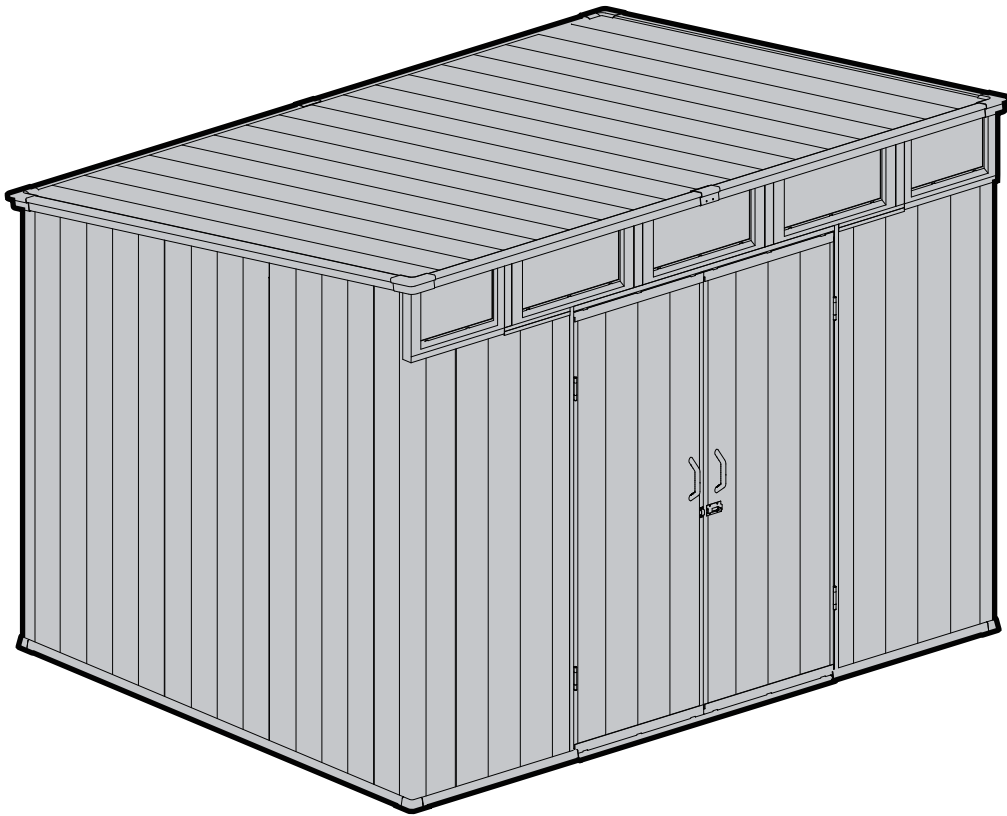

Version 1.0  
Revised 19.Feb.2025