

# CABANON DESIGN

## **2 Versants 8'x8'** *2-sided Shed 8'x8'*

*Guide d'utilisation / Manual*

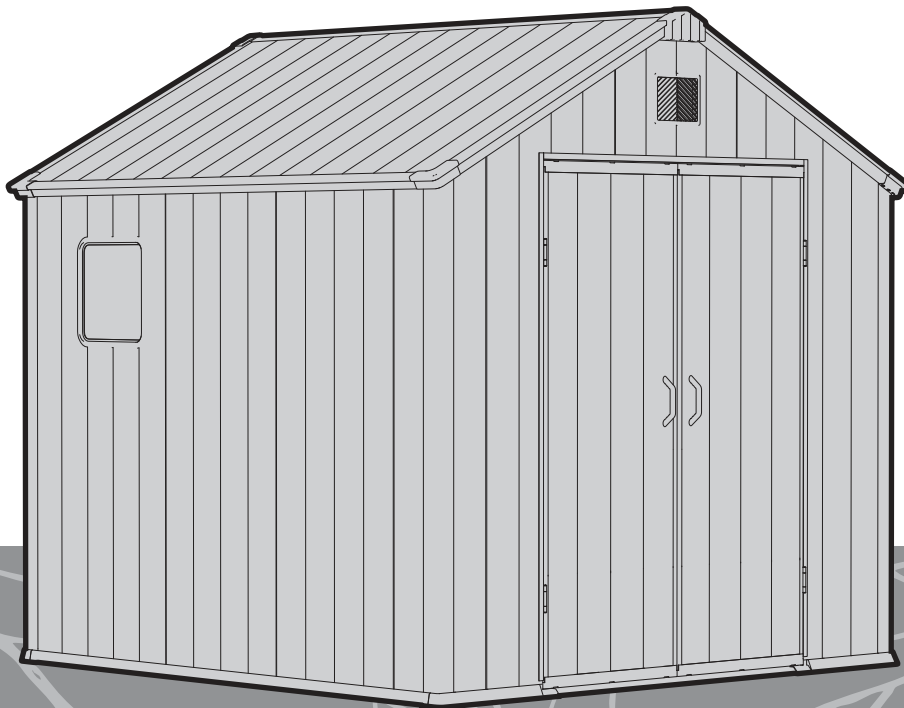

Version 2.0  
Revised 18.Jan.2025



# ▪ SOMMAIRE / CONTENT ▪

**AVANT L'ASSEMBLAGE ILLUSTRATION**  
BEFORE ASSEMBLE ILLUSTRATION ..... 01

**LISTE DES PIÈCES / PARTS LIST** ..... 03

**ASSEMBLAGE DU PLANCHER**  
FLOOR ASSEMBLY ..... 11

**ASSEMBLAGE DU CADRE**  
FRAME ASSEMBLY ..... 19

**ASSEMBLAGE DES MURS**  
WALL ASSEMBLY ..... 25

<b>ASSEMBLAGE DU TOIT</b>	
ROOF ASSEMBLY .....	<b>39</b>

<b>ASSEMBLAGE DE LA PORTE</b>	
DOOR ASSEMBLY .....	<b>51</b>

<b>DIRECTIVES ET GARANTIE</b>	
GUIDELINES & WARRANTY .....	<b>63</b>

# Préparation du site / Site Preparation

**Niveler la surface du sol**  
Level the ground surface

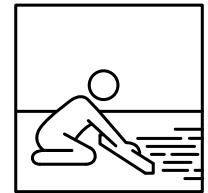
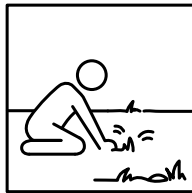

## Recommandation de la plateforme Platform Recommendation

**Option A**  
Bois / Wooden

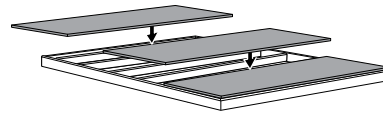

**Option B**  
Béton / Concrete

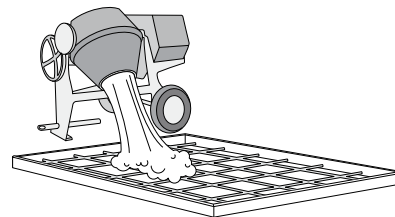

**Option C**  
Sol / Soil

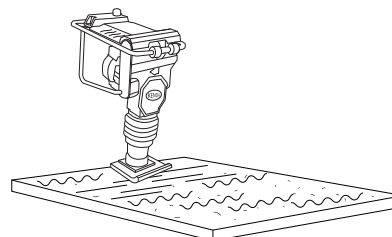

# Avant de commencer l'assemblage



## Before Starting Assembly

Lisez les consignes d'entretien et de sécurité à la fin de ce manuel. Vérifiez qu'aucune pièce ne manque ou n'est endommagée avant de commencer ou d'organiser l'assemblage. Passez en revue toutes les instructions d'assemblage. Assemblez toutes les pièces conformément aux instructions de ce manuel. Ne sautez aucune étape.

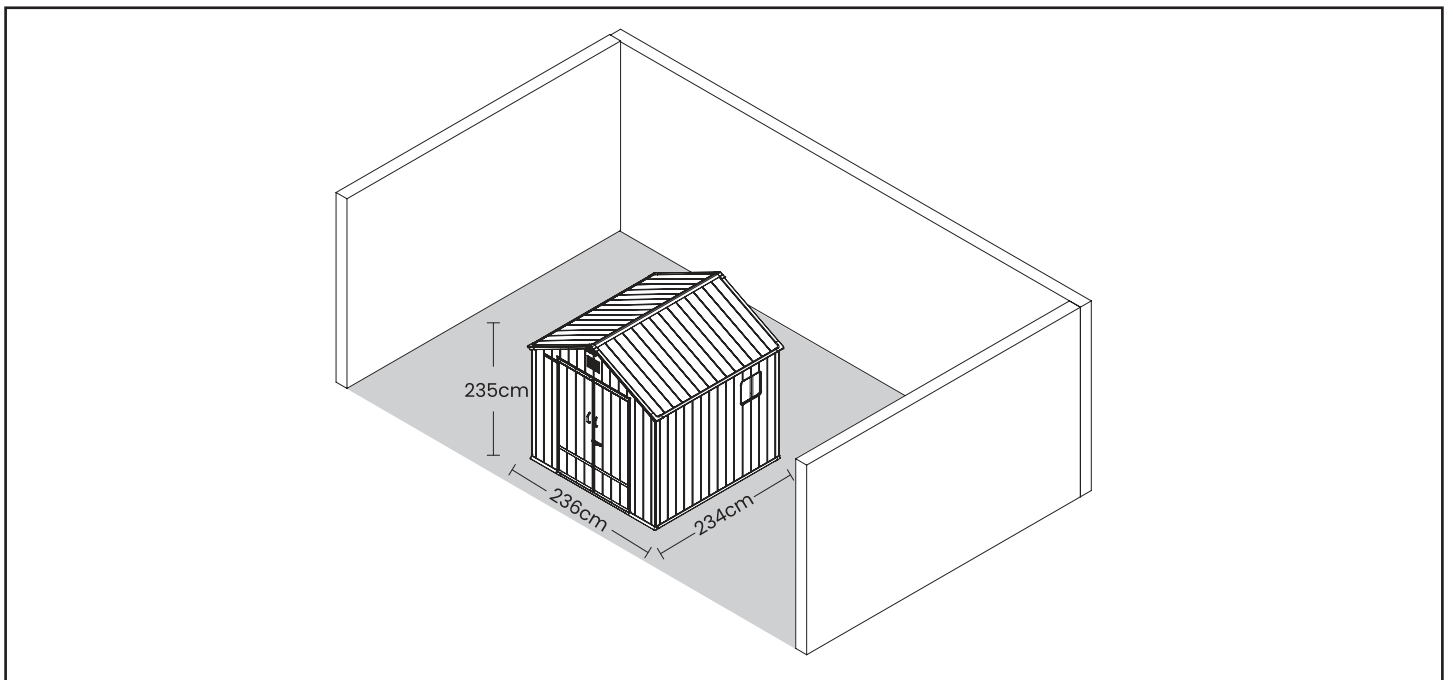
Read the care and safety guidelines at the end of this manual. Check to ensure that there are no missing or damaged parts before starting or arranging assembly. Review all assembly instructions. Assemble all the parts according to the directions in this manual. Do not skip any steps.

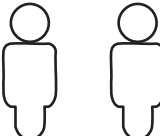

Pour l'accès extérieur pendant le montage, veillez à laisser suffisamment d'espace autour du site de montage de l'abri de jardin. For external access during assembly, make sure to leave enough room around the outside of the shed assembly site.

<p><b>2 personnes requises</b> 2 People Required</p>	
<p><b>Outils nécessaires</b> Tools Needed</p>	



# Liste des pièces / Parts List

Retirez toutes les pièces de l'emballage et étalez-les sur une surface de travail propre. Des lettres de code sont imprimées sur chaque pièce pour en faciliter l'identification. Remove all parts from the package(s) and spread them out on a clean work surface. Code letters are imprinted on each part for easy identification.

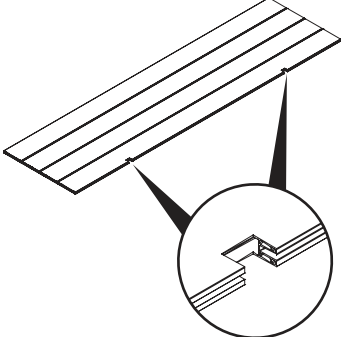
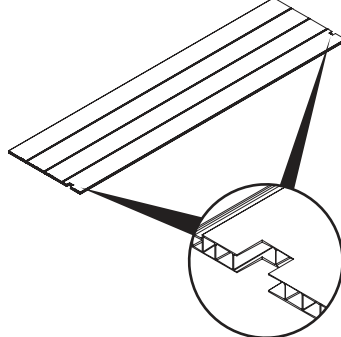
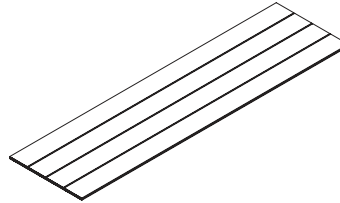
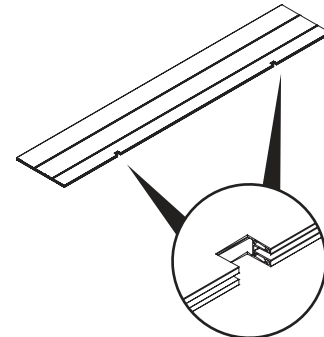
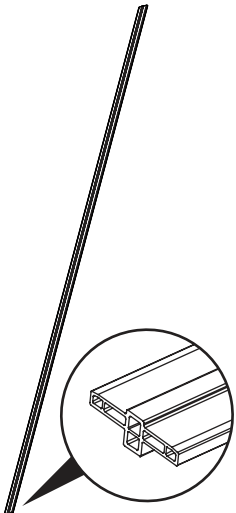
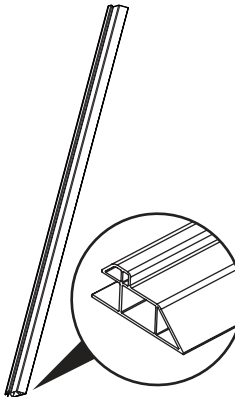
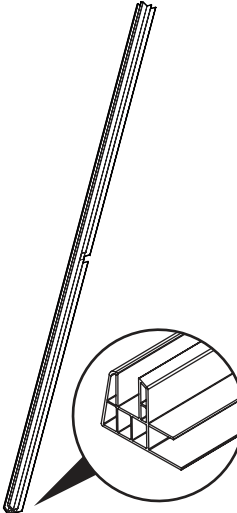
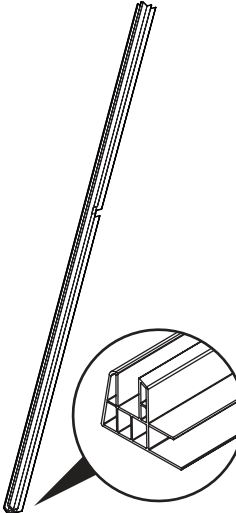
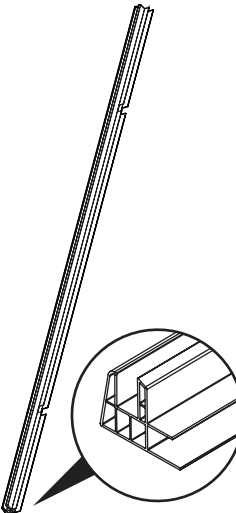
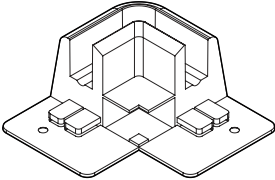
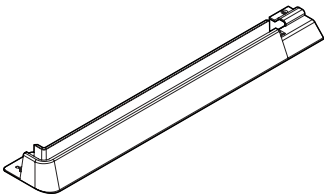
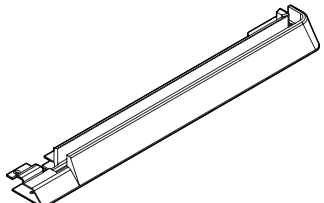
## Pièces de plancher / Floor Parts

<p>KD098</p>  <p>2219 x 600 mm</p>	<p>KD099</p>  <p>2219 x 600 mm</p>	<p>KD100</p>  <p>2219 x 600 mm</p>	<p>KD101</p>  <p>2219 x 400 mm</p>	
<p>KD102</p>  <p>2219 mm x3</p>	<p>KD009</p> 	<p>KD103</p> 	<p>KD104</p> 	<p>KD105</p> 
<p>KD015</p>  <p>x2</p>		<p>KD016</p> 	<p>KD017</p> 	

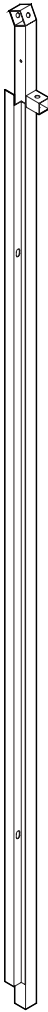
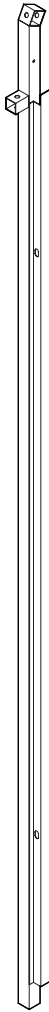
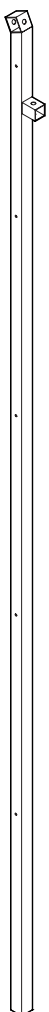
# Pièces du cadre / Frame Parts

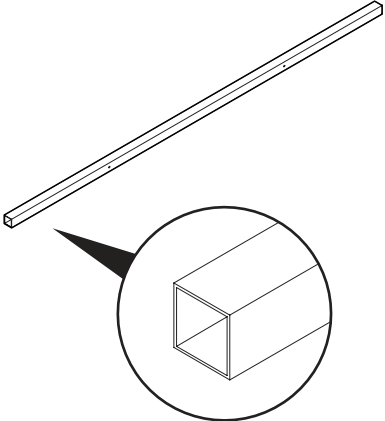
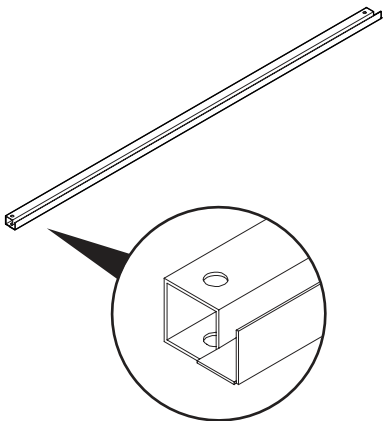
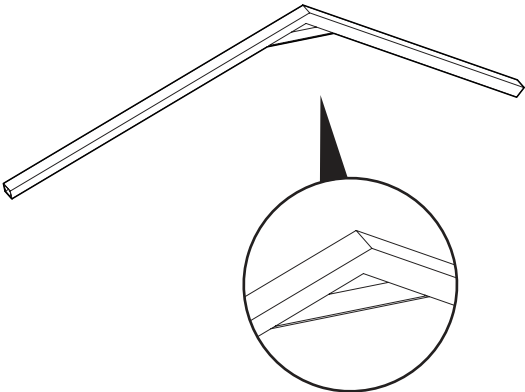
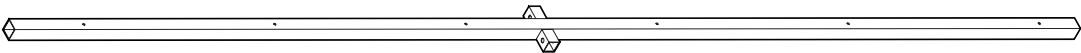
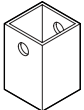

KD019	KD020	KD021	KD022	KD106
				 <p style="text-align: right;">x2</p>
KD025	KD026	KD027		
				
KD028				KD029
 <p style="text-align: right;">x2</p>				 <p style="text-align: right;">x6</p>



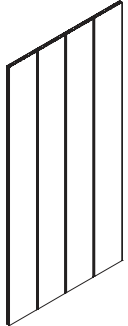

# Pièces murales / Wall Parts

KD107	KD108	KD110	KD109	KD037	KD036
				 x2	 x2
KD038	KD039	KD111	KD042	KD043	KD112
 1730 x 600 mm x6			 400 mm x2	 1730 mm x6	 2130 mm x2
KD041	KD045	KD046	KD047	KD048	KD049

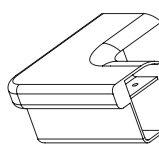
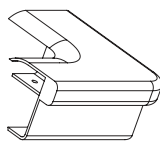
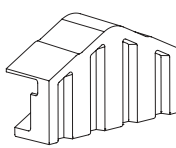
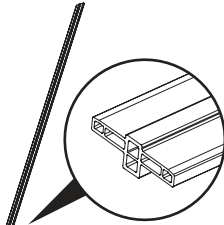
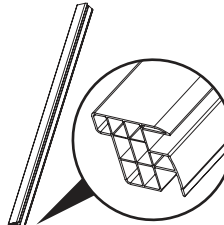
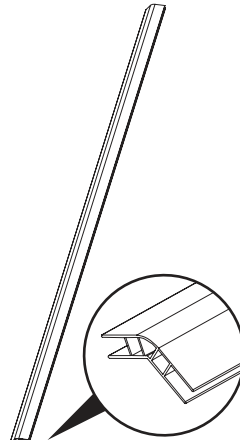
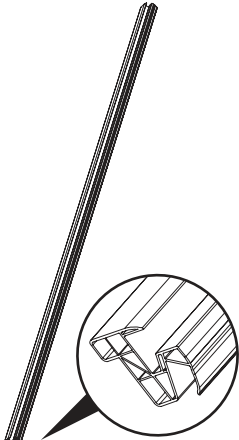
## Pièces de toit / Roof Parts

KD050	KD051	KD052	KD053	KD054
 <p data-bbox="143 555 351 582">1265 x 640 mm x6</p>	 <p data-bbox="430 555 638 582">1265 x 320 mm x2</p>	 <p data-bbox="893 555 925 582">x2</p>	 <p data-bbox="1189 555 1220 582">x2</p>	 <p data-bbox="1476 555 1508 582">x2</p>
KD055	KD056	KD113	KD114	
 <p data-bbox="199 1108 422 1135">1265 mm x6</p>	 <p data-bbox="750 1108 782 1135">x4</p>		 <p data-bbox="1476 1108 1508 1135">x2</p>	

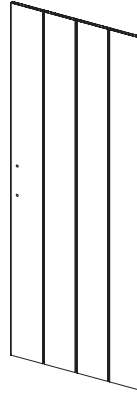
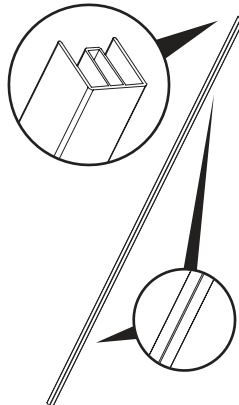
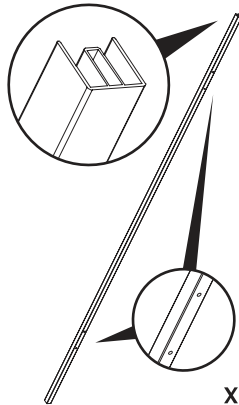
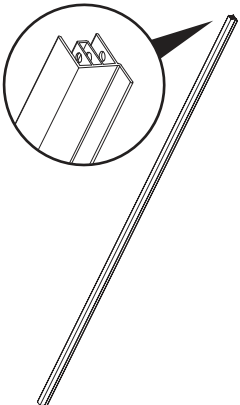
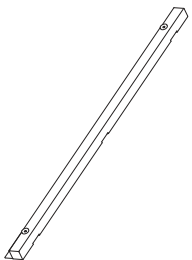
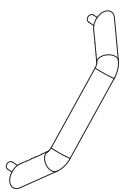
## Pièces pour portes / Door Parts

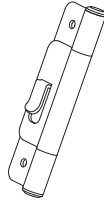
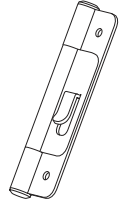
KD061	KD062	KD066	KD067	KD068
			 <p data-bbox="1181 1713 1212 1740">x2</p>	
KD069	KD070	KD071	KD072	KD073
 <p data-bbox="311 2072 343 2098">x4</p>	 <p data-bbox="598 2072 630 2098">x2</p>	 <p data-bbox="893 2072 925 2098">x2</p>	 <p data-bbox="1181 2072 1212 2098">x2</p>	 <p data-bbox="1476 2072 1508 2098">x2</p>

# Matériel / Hardware

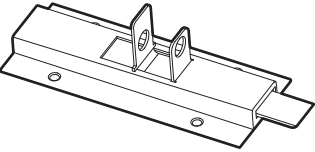
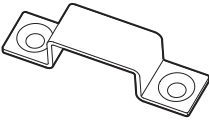
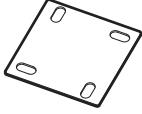
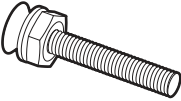
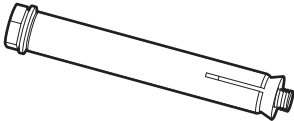
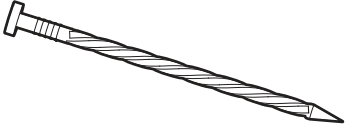
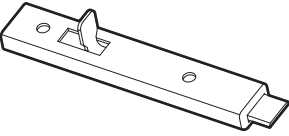
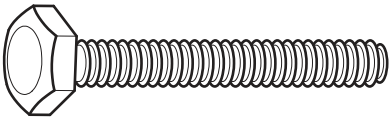
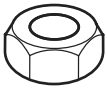
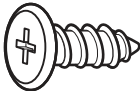
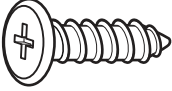
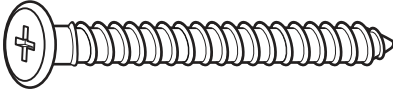
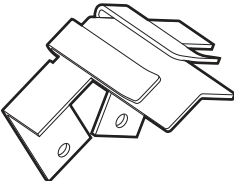
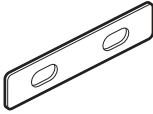
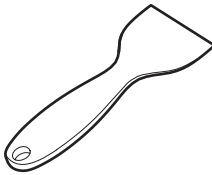
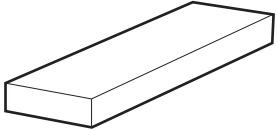
<p>KD075</p> 	<p>KD076</p> 	<p>KD077</p> 	
<p>KD078</p>  <p>x8</p>	<p>KD080</p>  <p>x7</p>	<p>KD118</p>  <p>x6</p>	
<p>KD079</p>  <p>x2</p>	<p>KD081</p>  <p>x18</p>	<p>KD082</p>  <p>x18</p>	
<p>KD083</p>  <p>x181</p>	<p>KD084</p>  <p>x16</p>	<p>KD085</p>  <p>x48</p>	
<p>KD074</p>  <p>x2</p>	<p>KD131</p>  <p>x2</p>	<p>KD119</p>  <p>x2</p>	<p>KD120</p> 

Assurez-vous que toutes les pièces sont complètes avant de procéder à l'installation.  
Ensure that all parts are complete before installation.

Outil supplémentaire Illustrer  
Extra Tool Illustrate

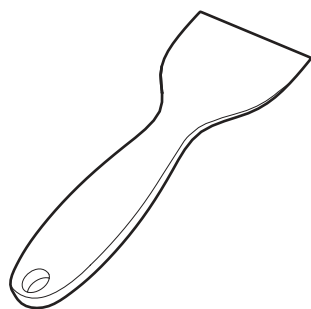

**KD119**

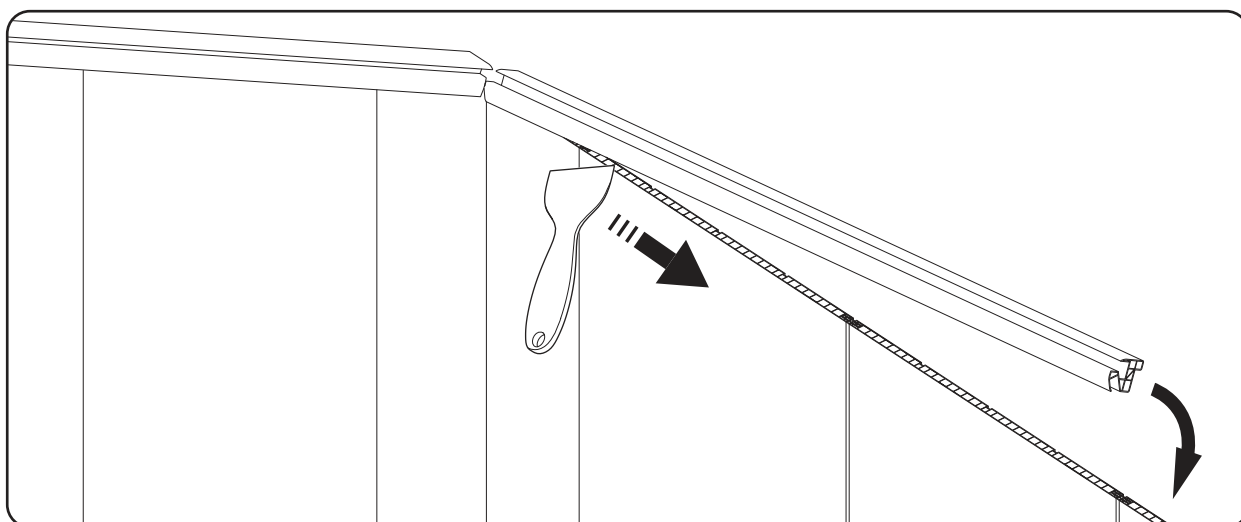
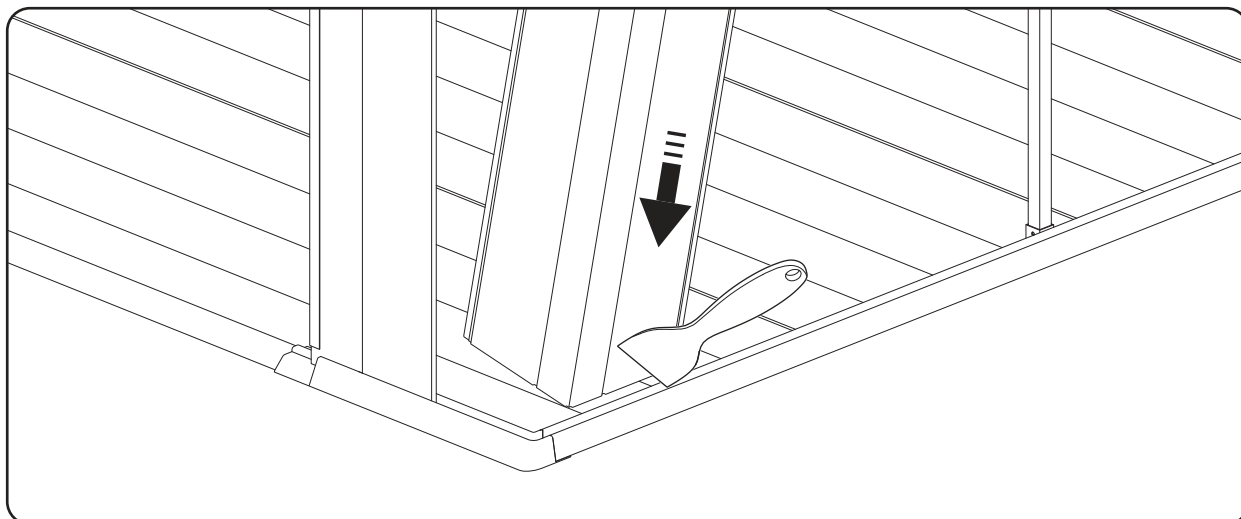

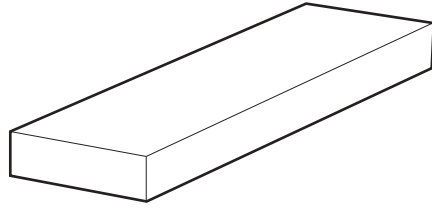

# KD120

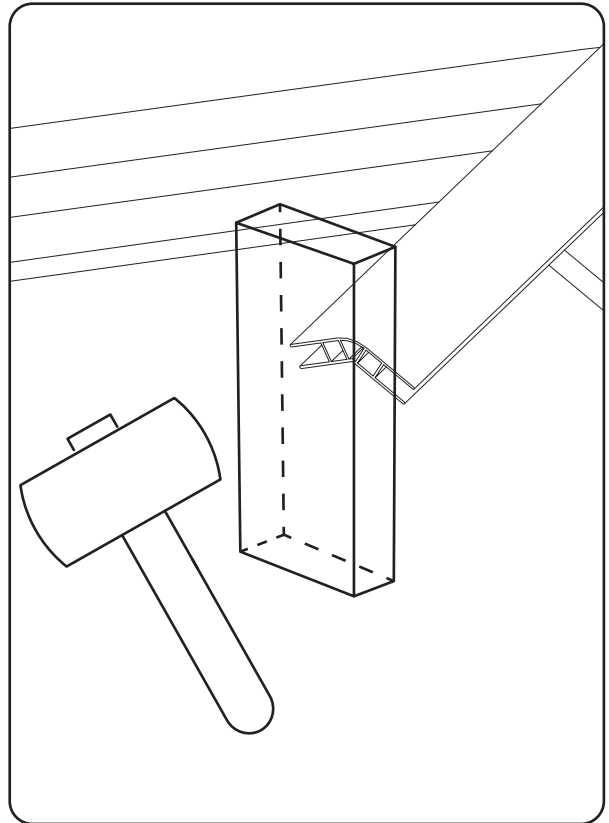
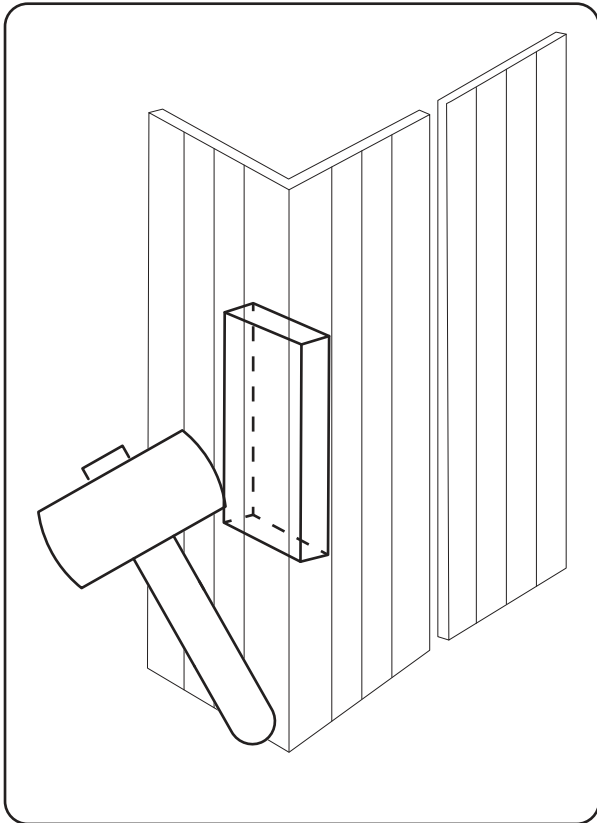
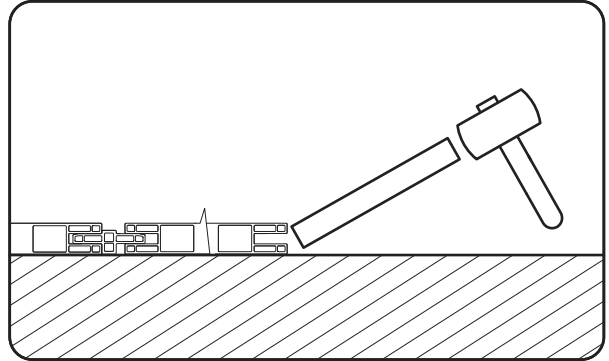
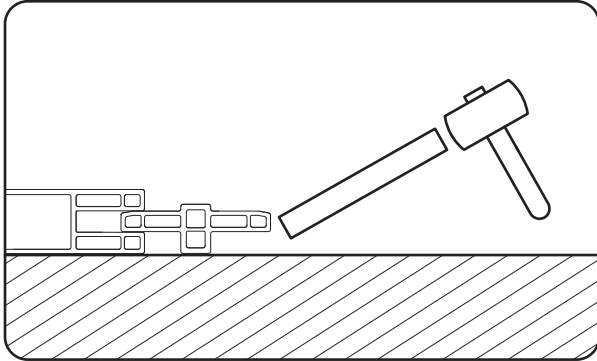





# Assemblage du plancher

## Floor Assembly





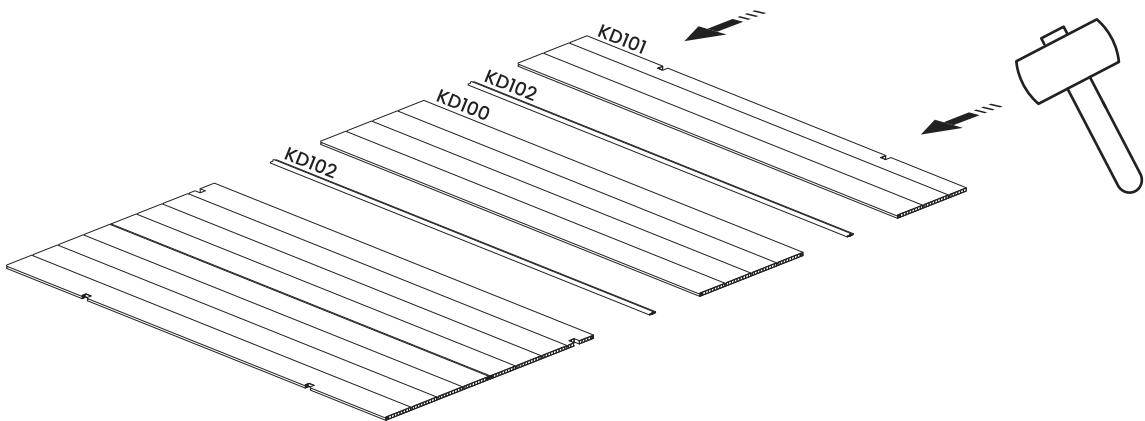
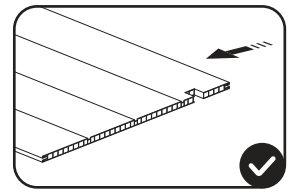
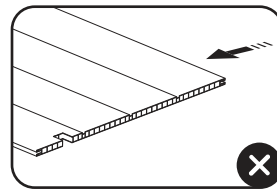
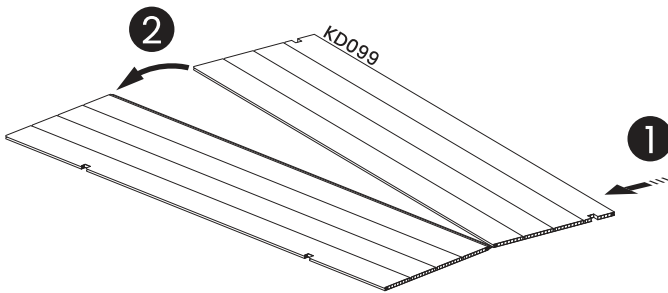
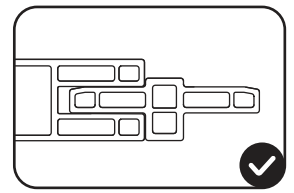
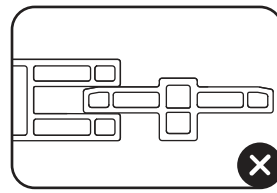
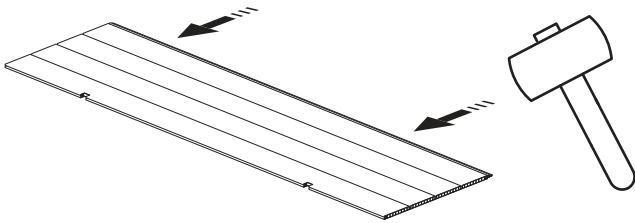
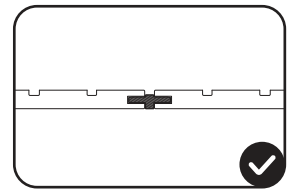
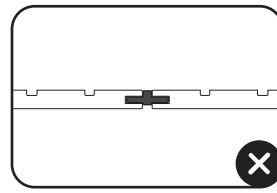
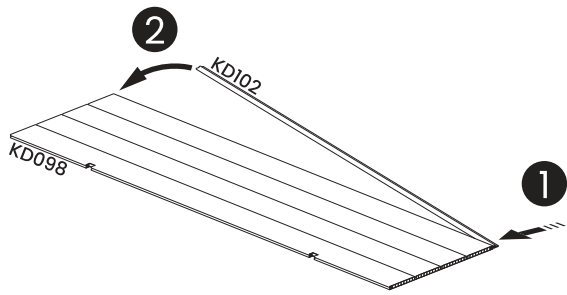

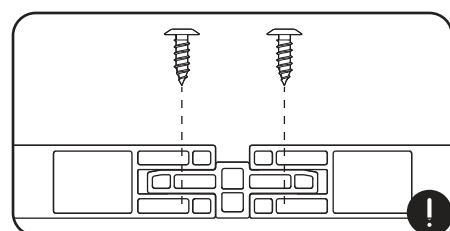
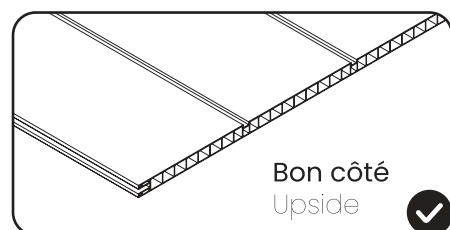
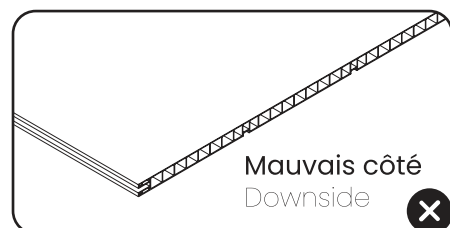
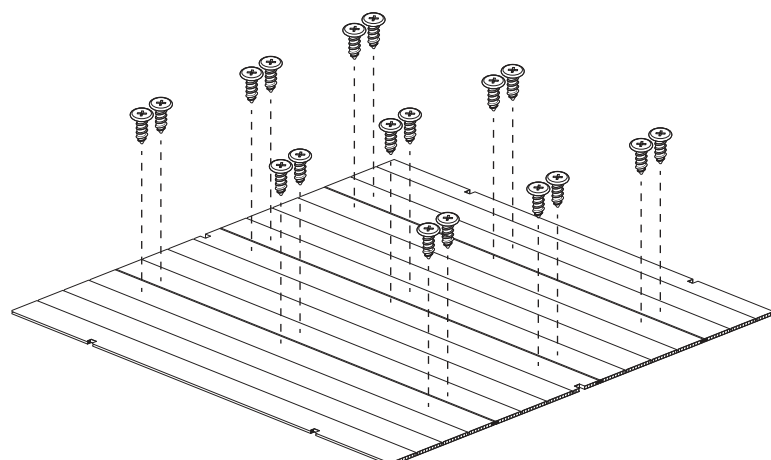
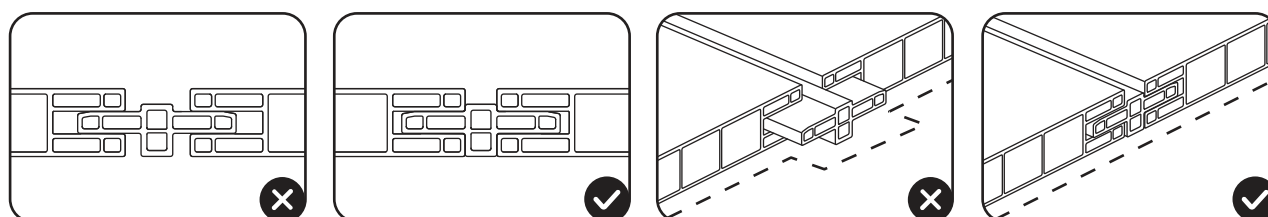
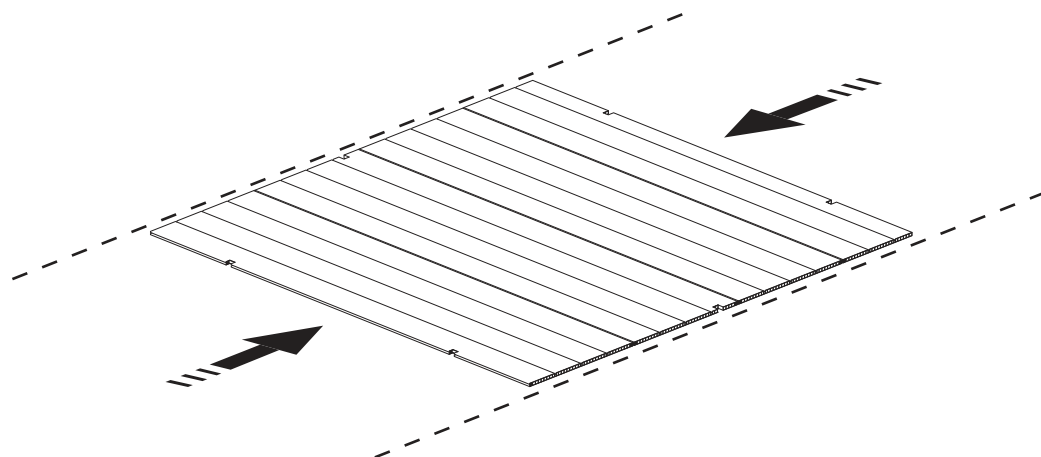

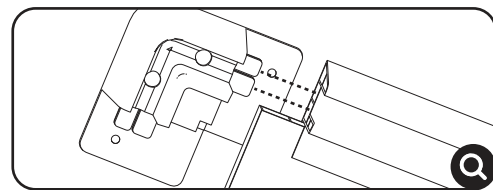
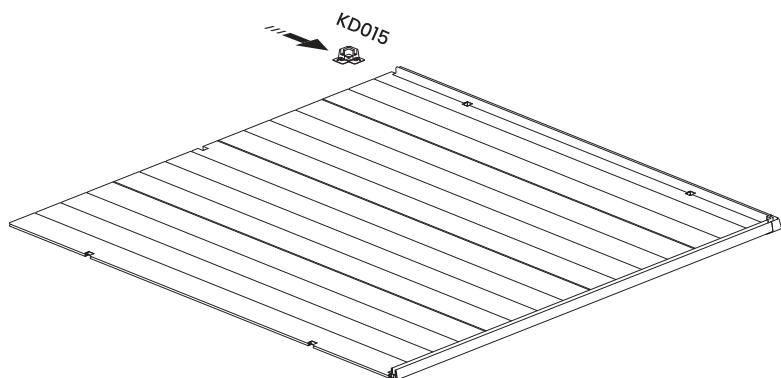
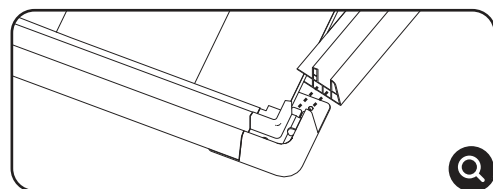
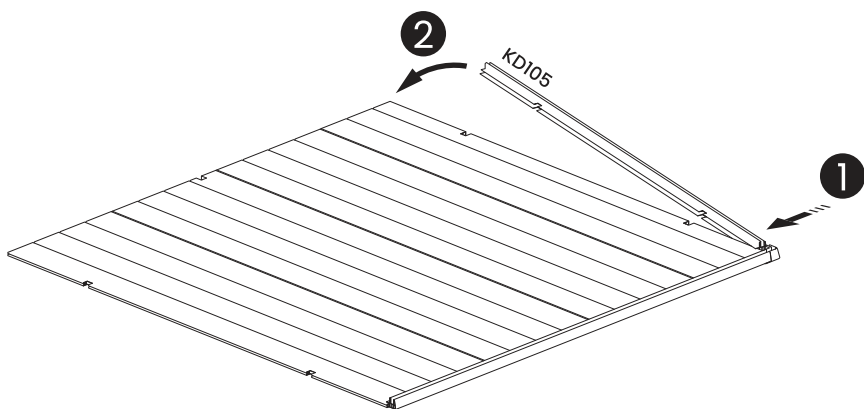
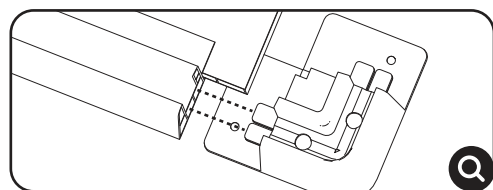
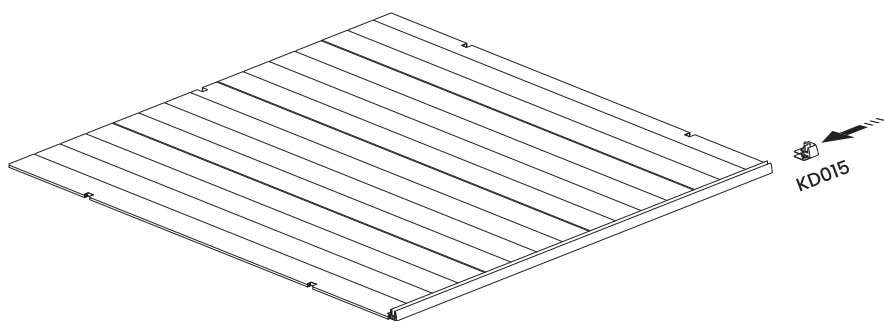
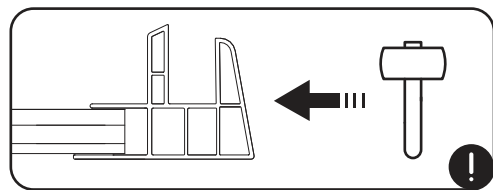
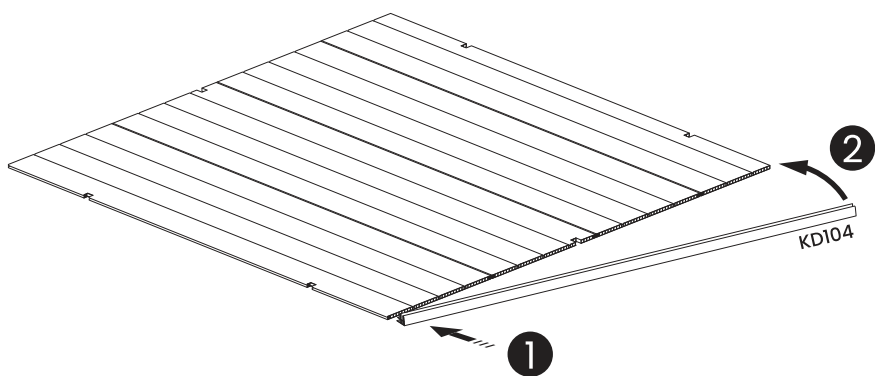

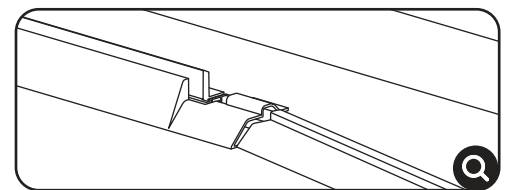
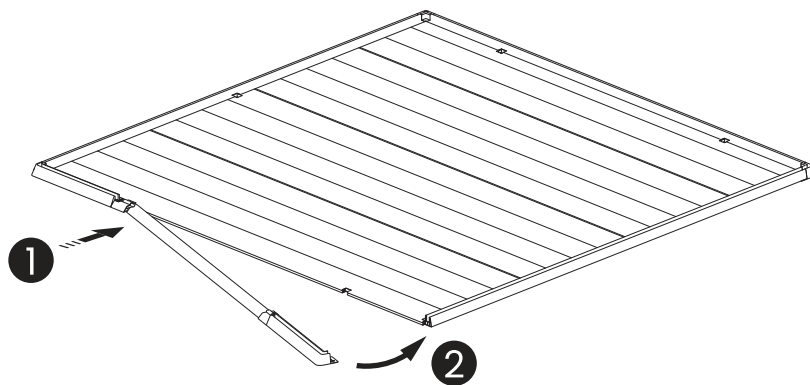
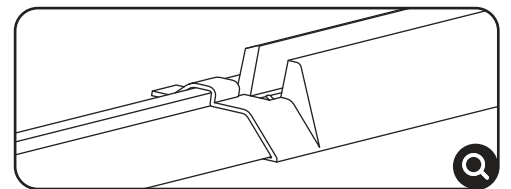
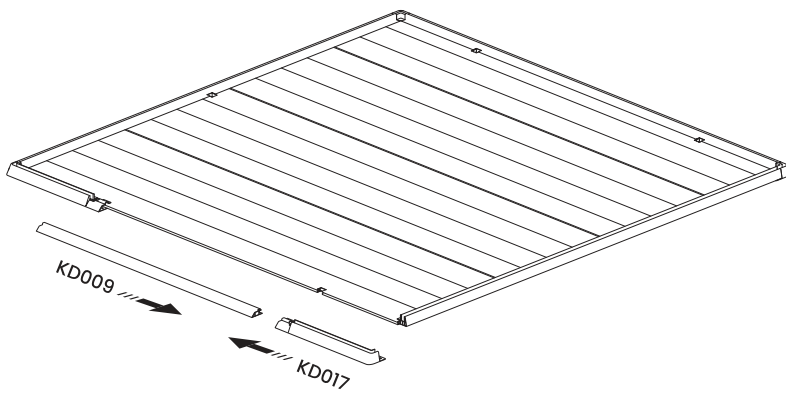
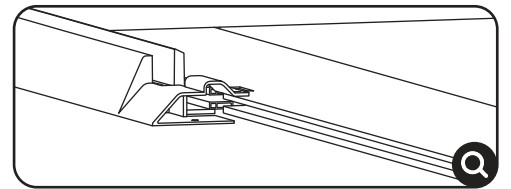
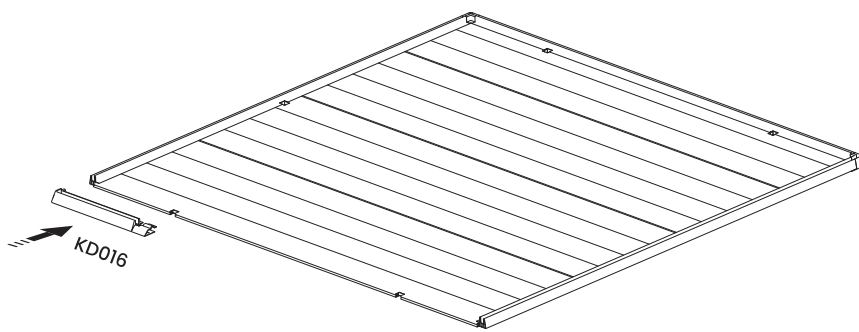
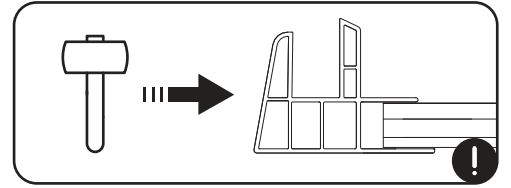
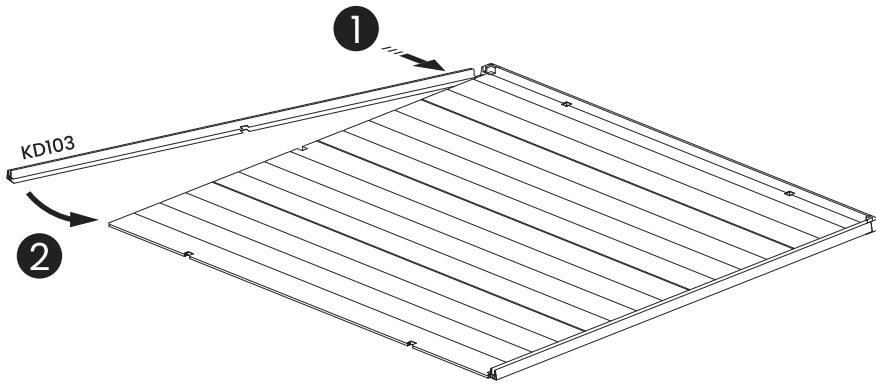



# Vérifier la marge sur une ligne

Check the margin on a line

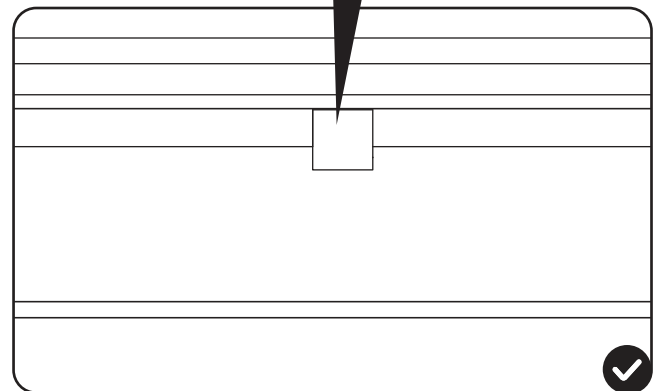
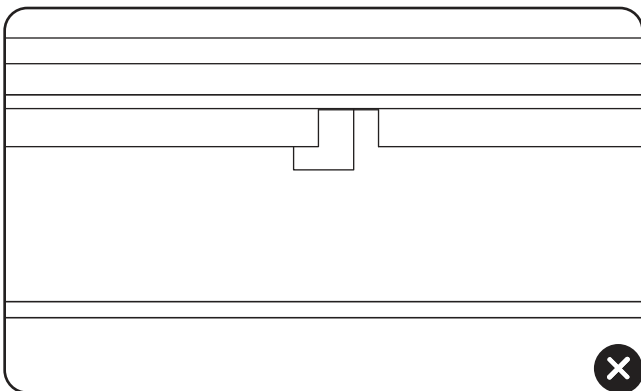
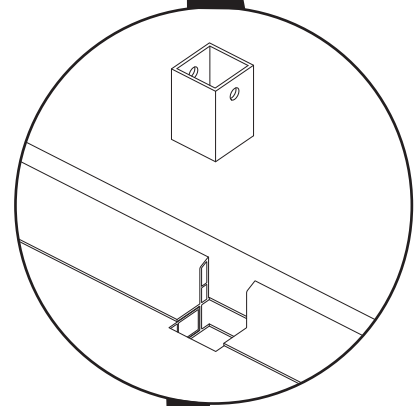
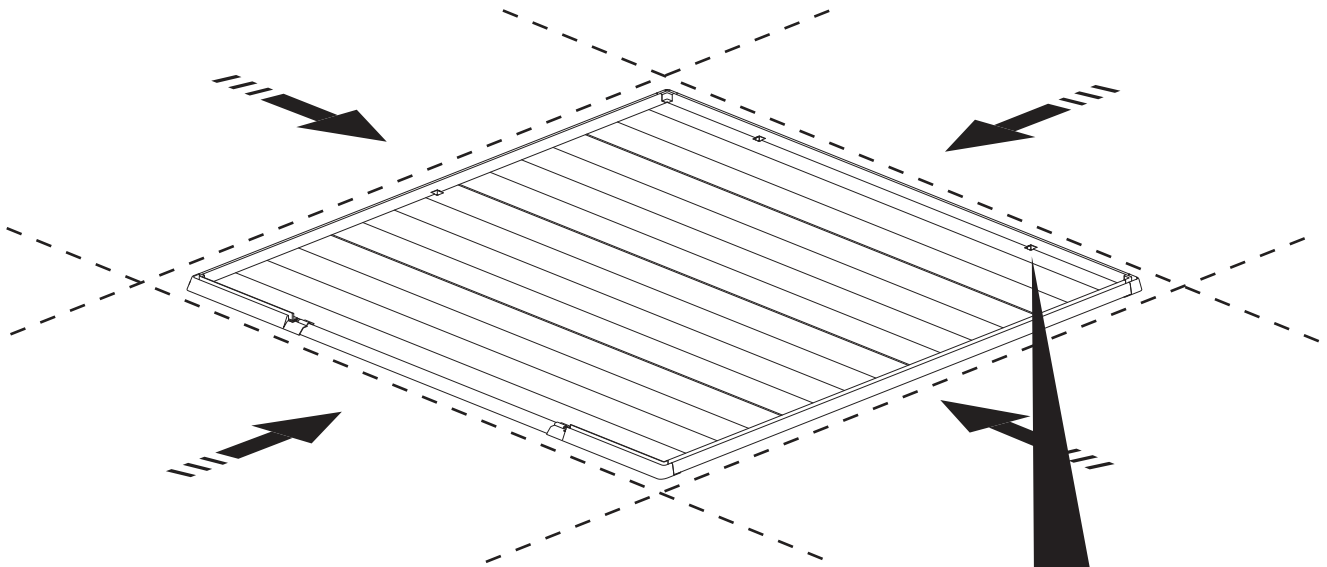

	KD083	x15
--	-------	-----

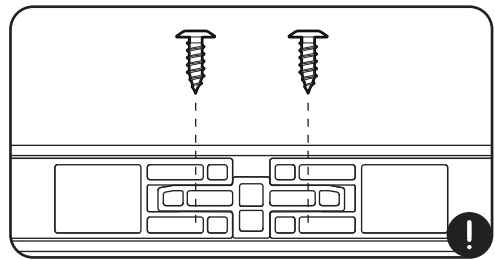
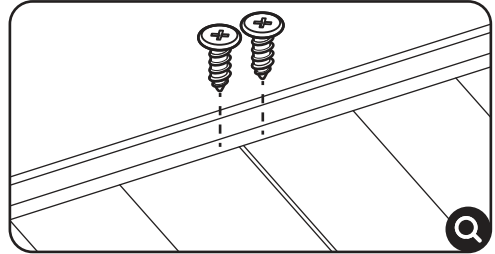
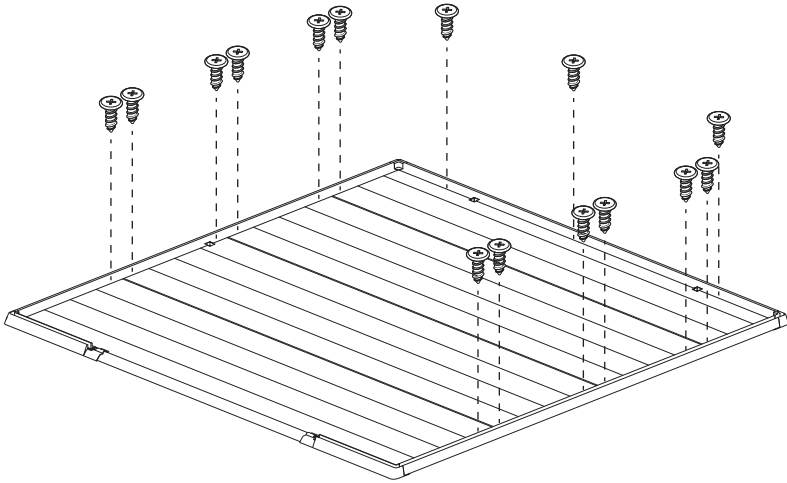

	KD083	x10
---	-------	-----

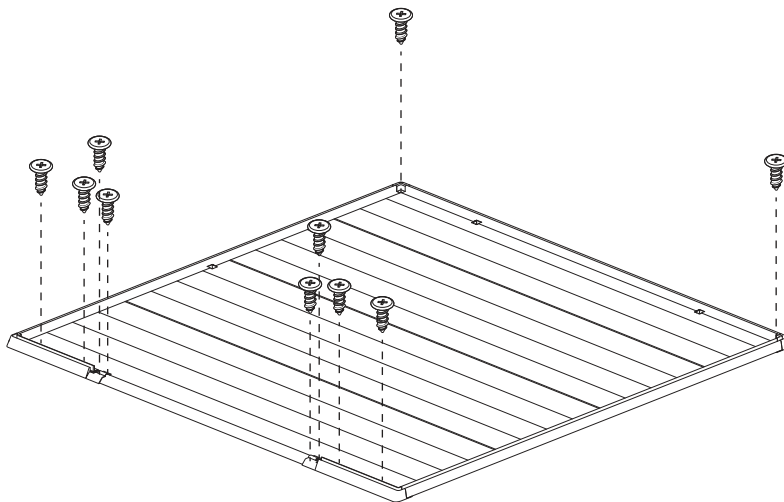





# Assemblage du cadre

## Frame Assembly



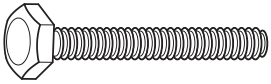

	KD081	x8		KD082	x8
--	-------	----	---	-------	----

Visser d'abord avec les mains. / Screw it with hands firstly. 

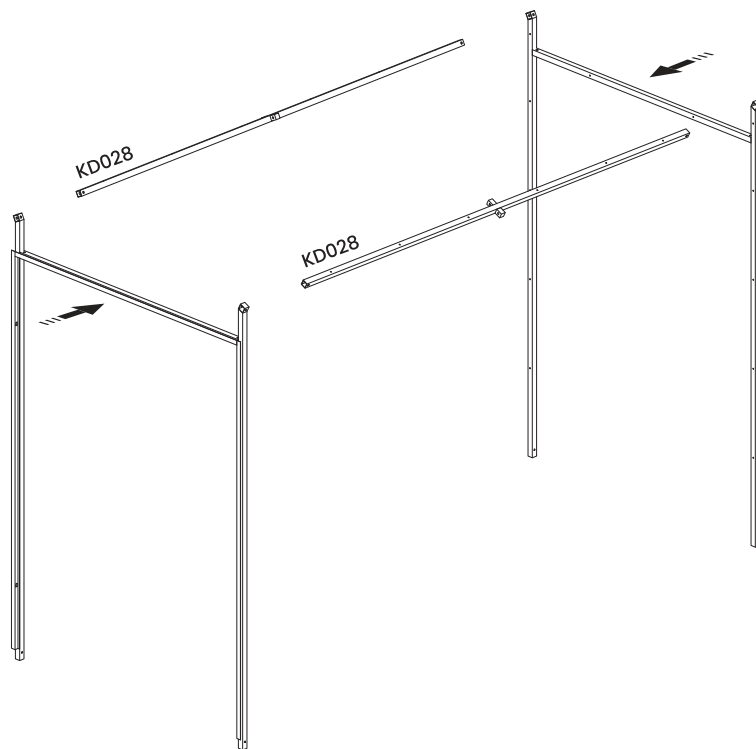
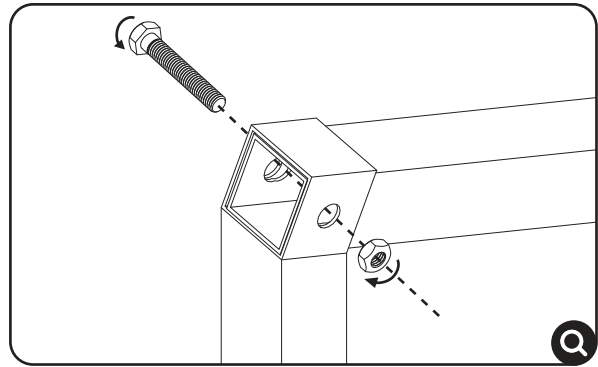
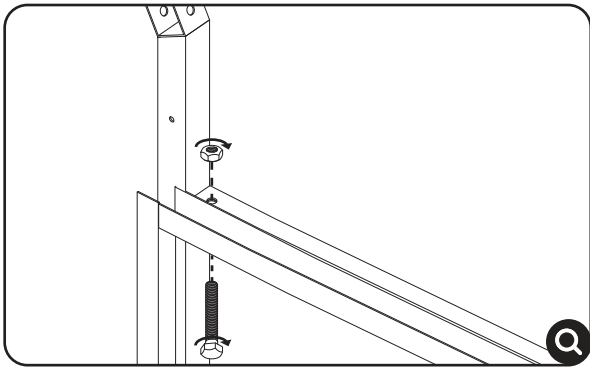
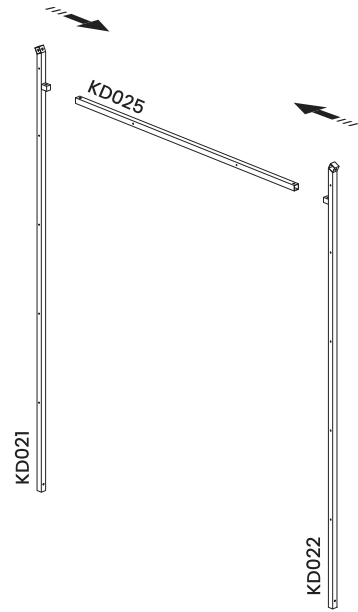
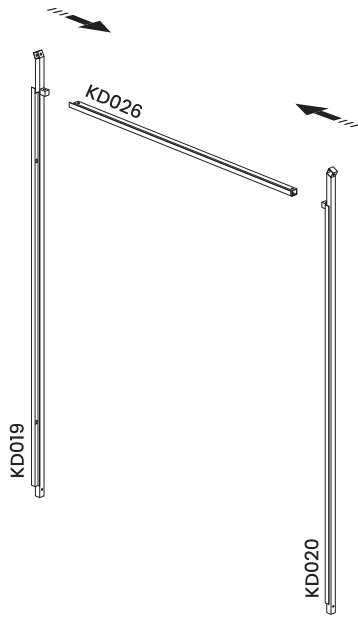

	KD081	x4		KD082	x4
--	-------	----	---	-------	----

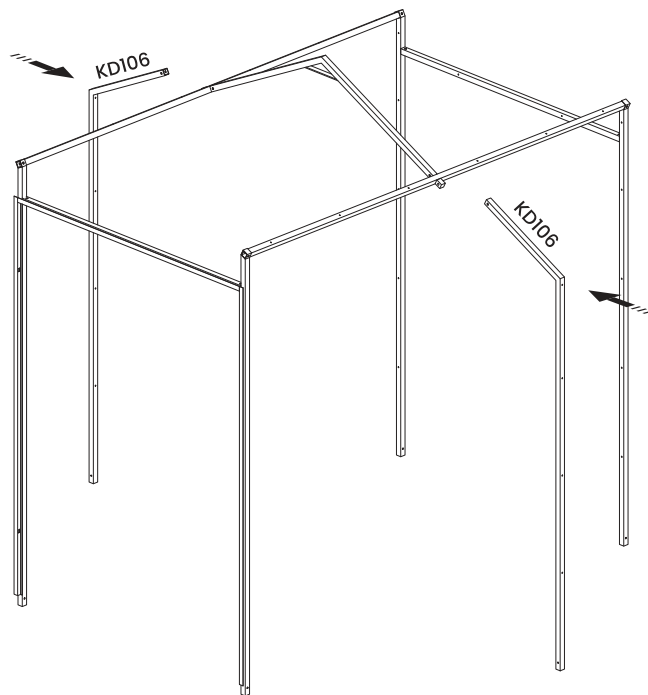
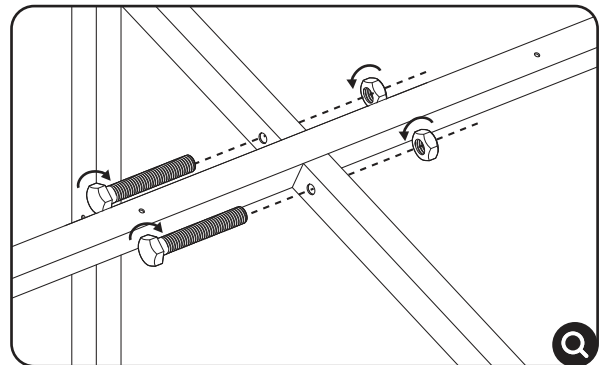
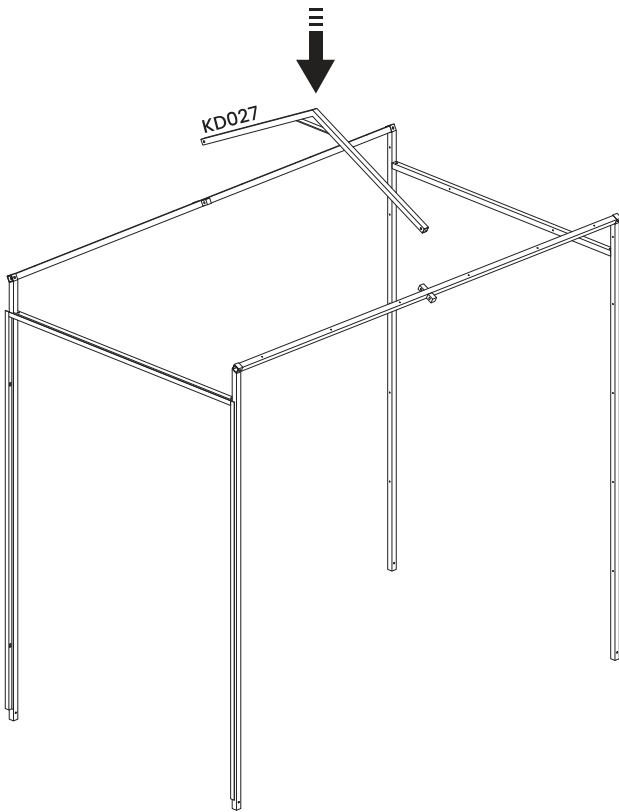

## Option A

Plancher en bois  
Wooden Floor

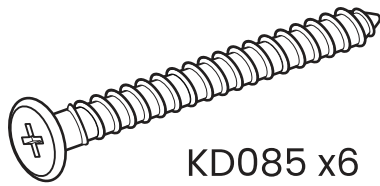

Retirer l'entretoise.  
Take off the spacer.

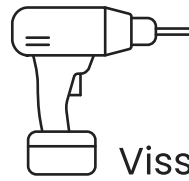
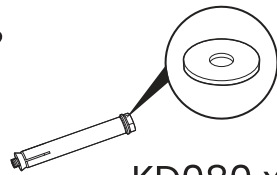

Visseuse  
Screwdriver

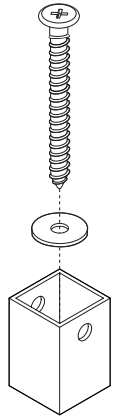

## Option B

Béton / Concrete Floor

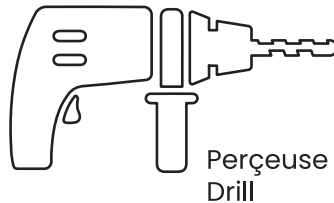
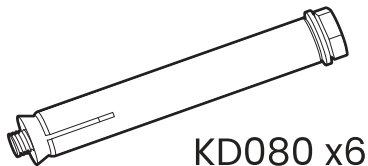

Perçuse  
Drill

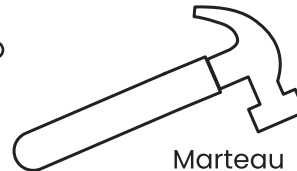

Marteau  
Hammer

Après avoir placé les fixations du cadre au niveau des ouvertures du plancher, utilisez une perceuse pour percer les trous en fonction de leur position. After placing the frame fixings at the floor openings, use a drill bit to make holes according to the hole positions.

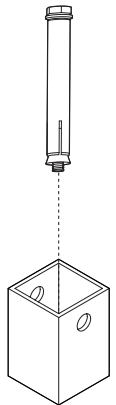

## Option C

Sol / Soil Ground

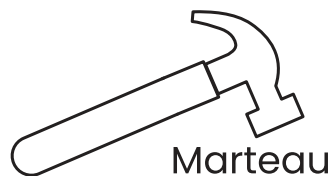
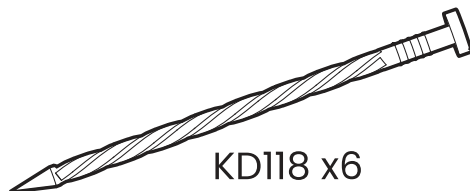

Marteau  
Hammer

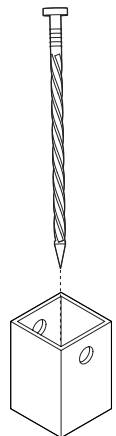

**Veillez utiliser un outil approprié pour enfoncer le KD080 ou le KD118, mais nous avons également offert un KD080 supplémentaire pour ce faire.**

Please use an appropriate tool to drive in the KD080 or the KD118, however we also offered an extra KD080 to do that.

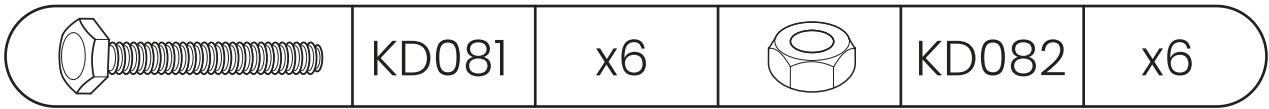

Serrer le tout à l'aide d'une clé à molette lorsque le cadre est posé. 

Tighten all of it with spanner when the frame is put down.

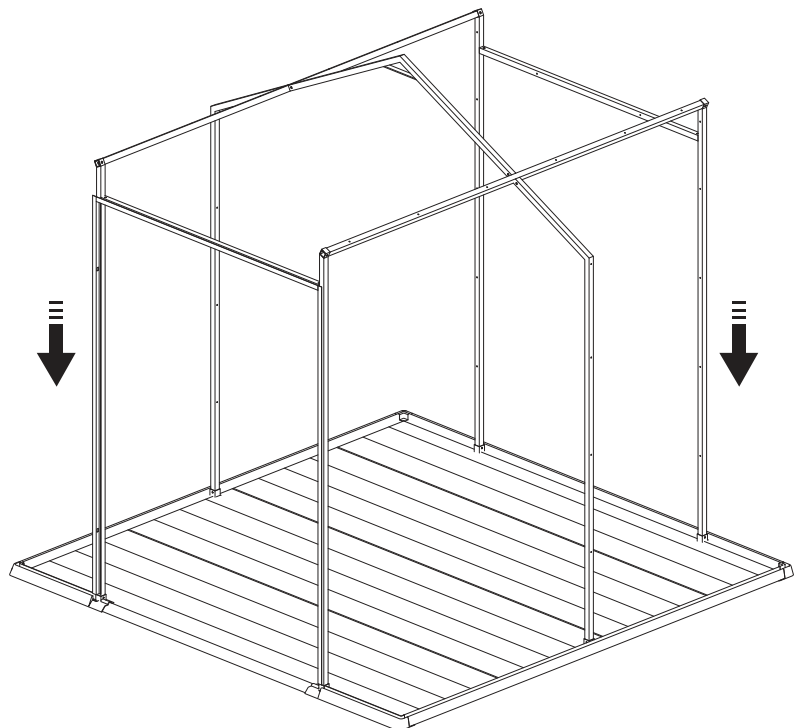
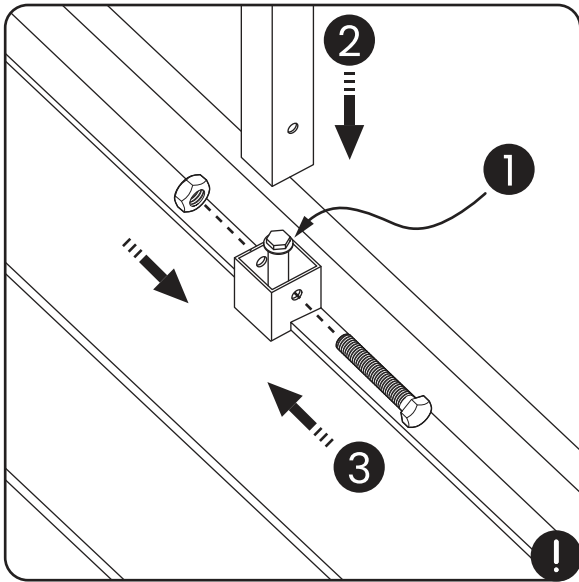
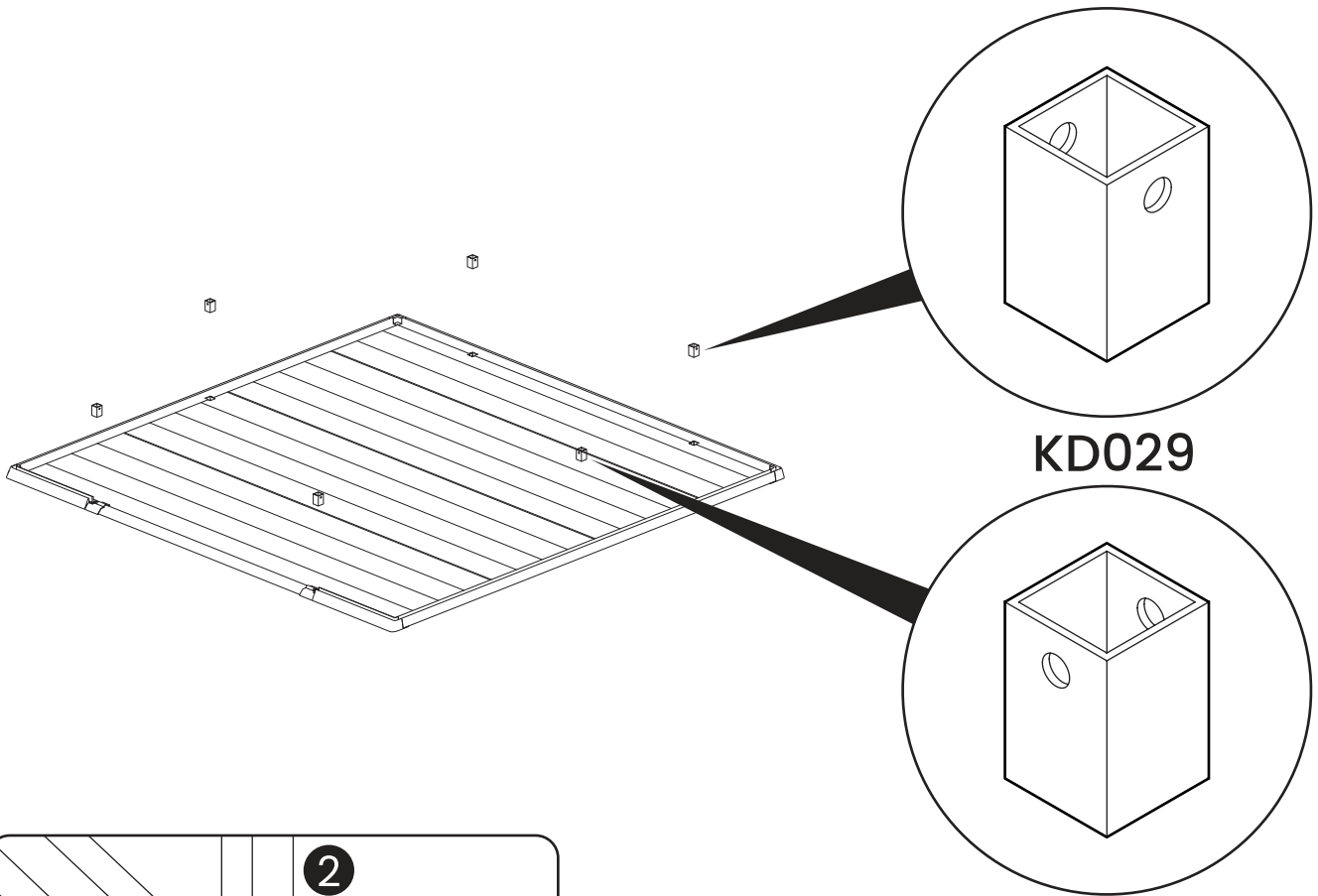



# Assemblage du mur

## Wall Assembly



# Choisissez la position de votre fenêtre

## Choose Your Window Position

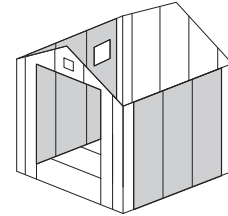

APERÇU  
OVERVIEW

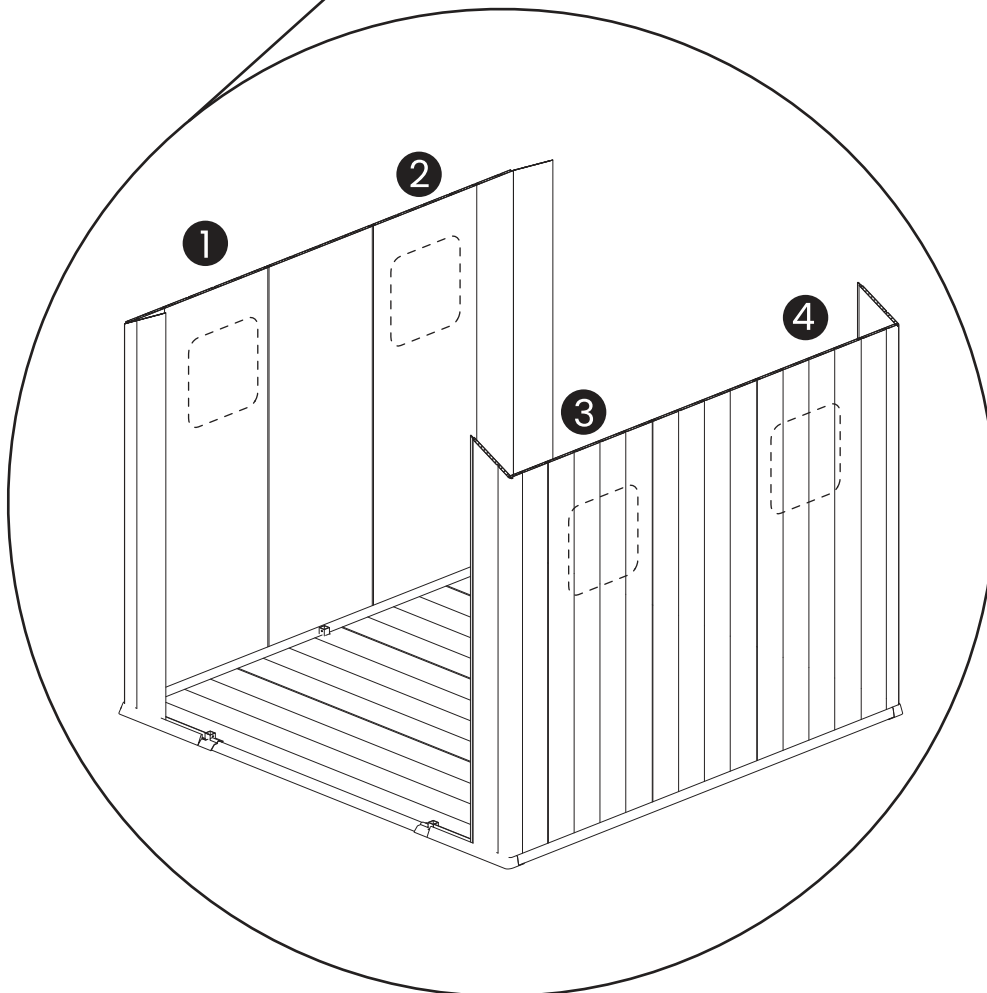

**2** est la position actuelle dans ce manuel.  
is current position in this manual.

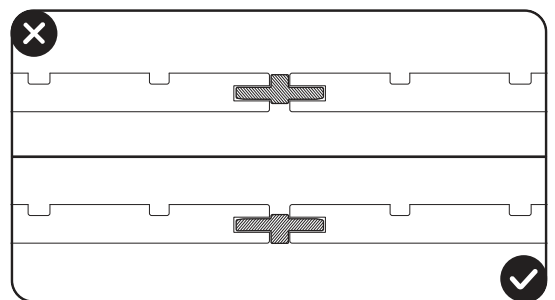
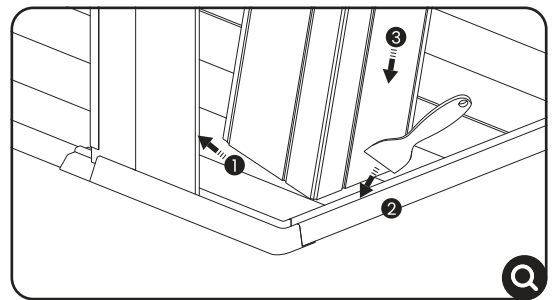
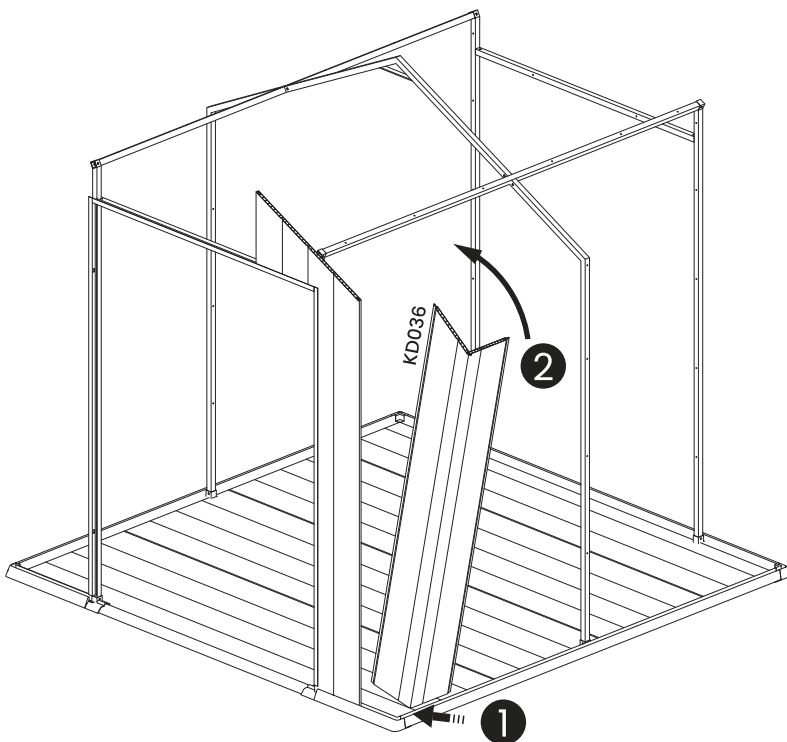
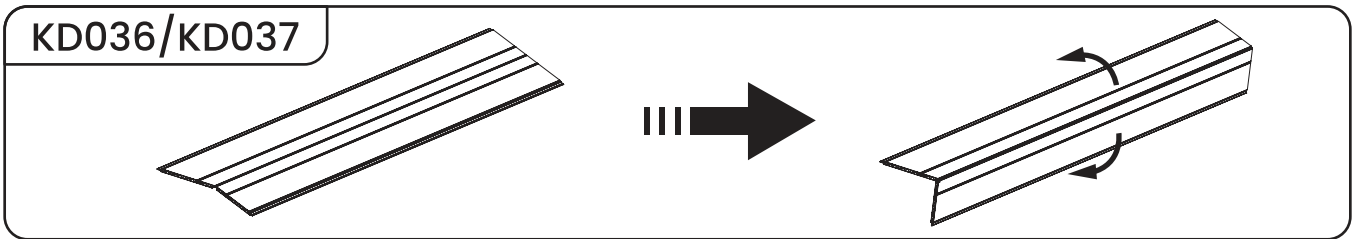
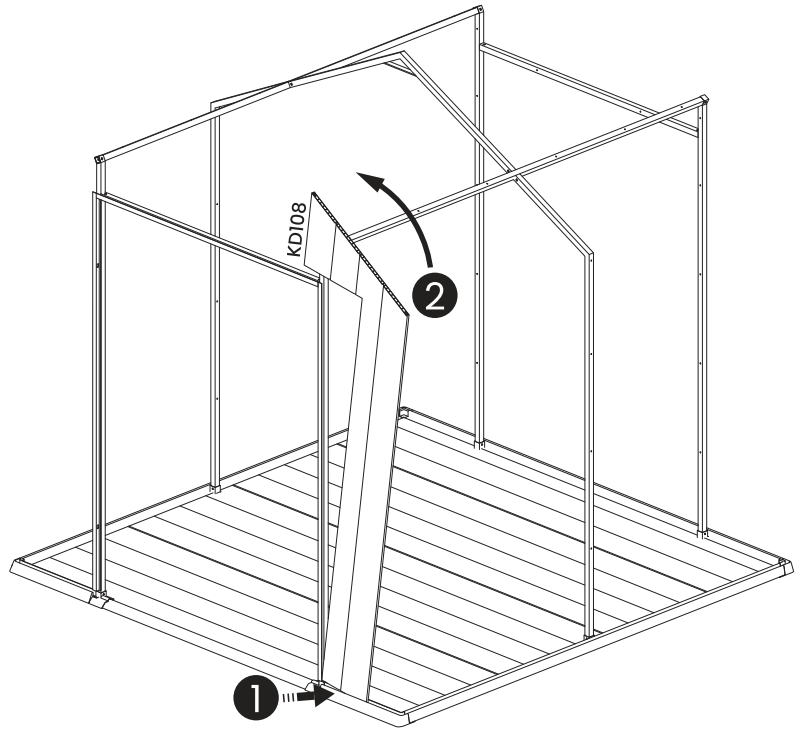
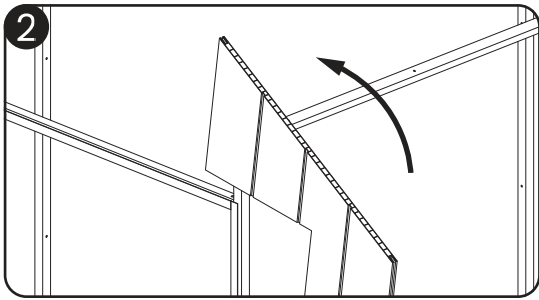
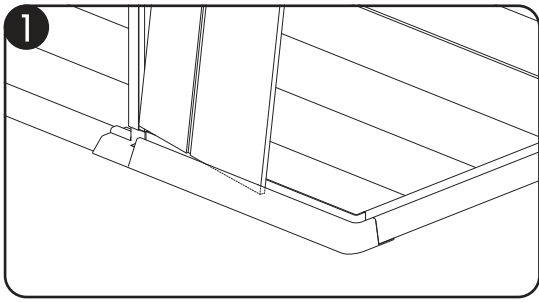

KD042/KD043/KD112



Étape 1 / Step 1

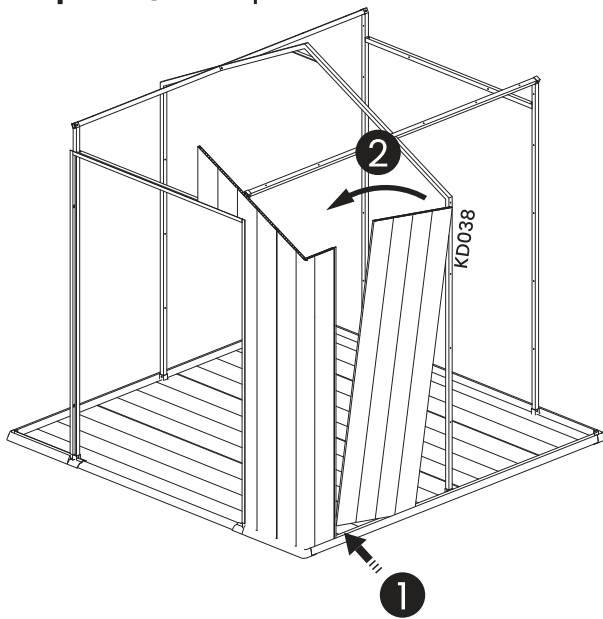

Étape 2 / Step 2

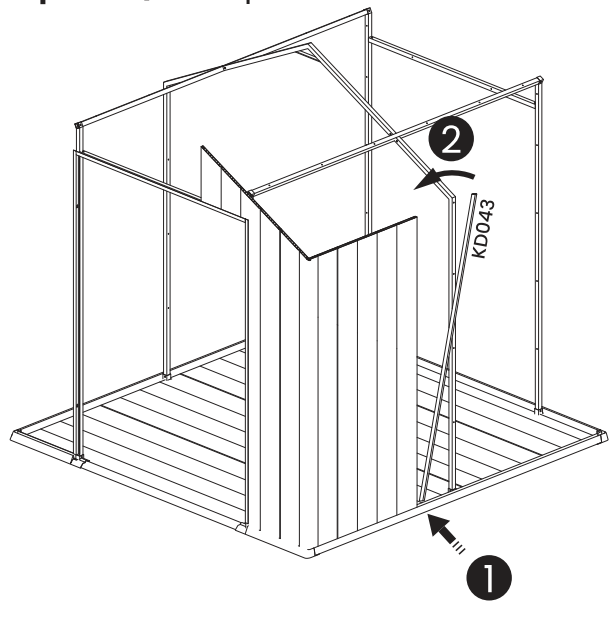

Étape 3 / Step 3

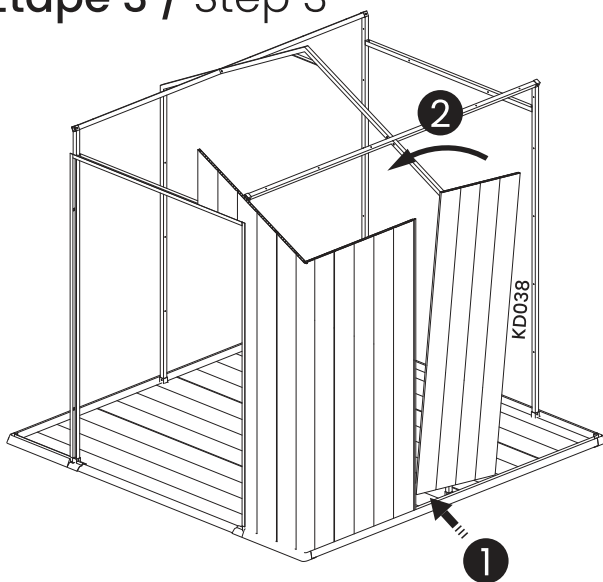

Étape 4 / Step 4

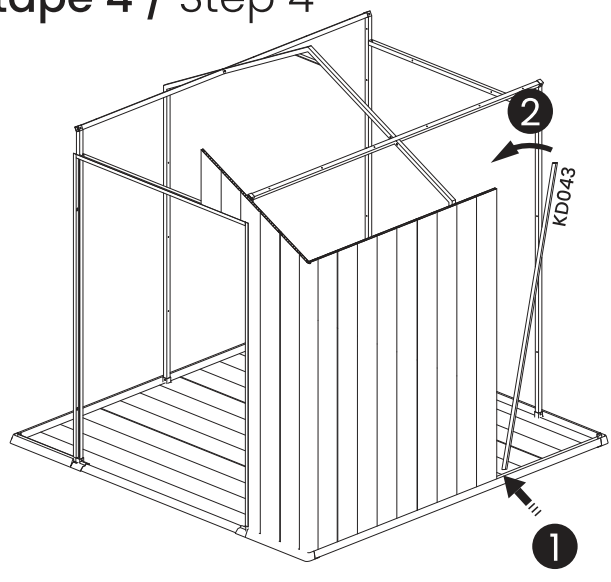

Étape 5 / Step 5

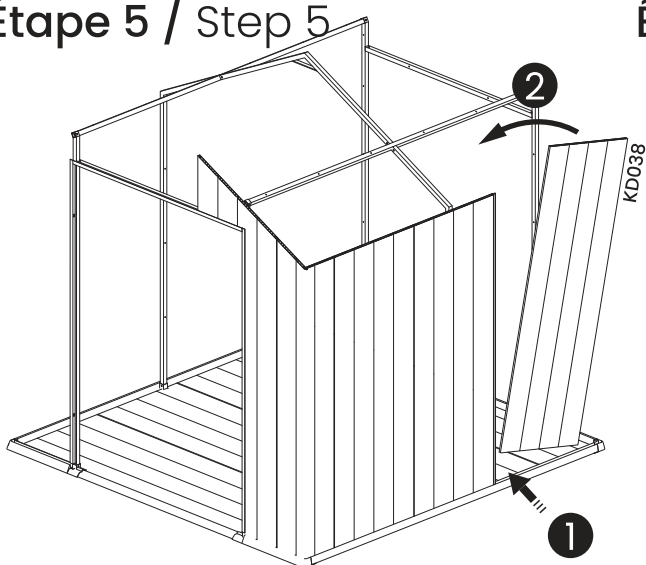

Étape 6 / Step 6

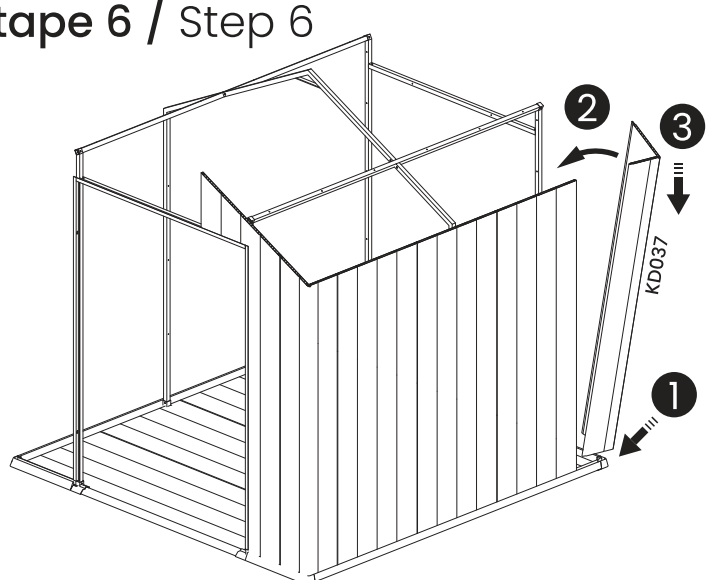

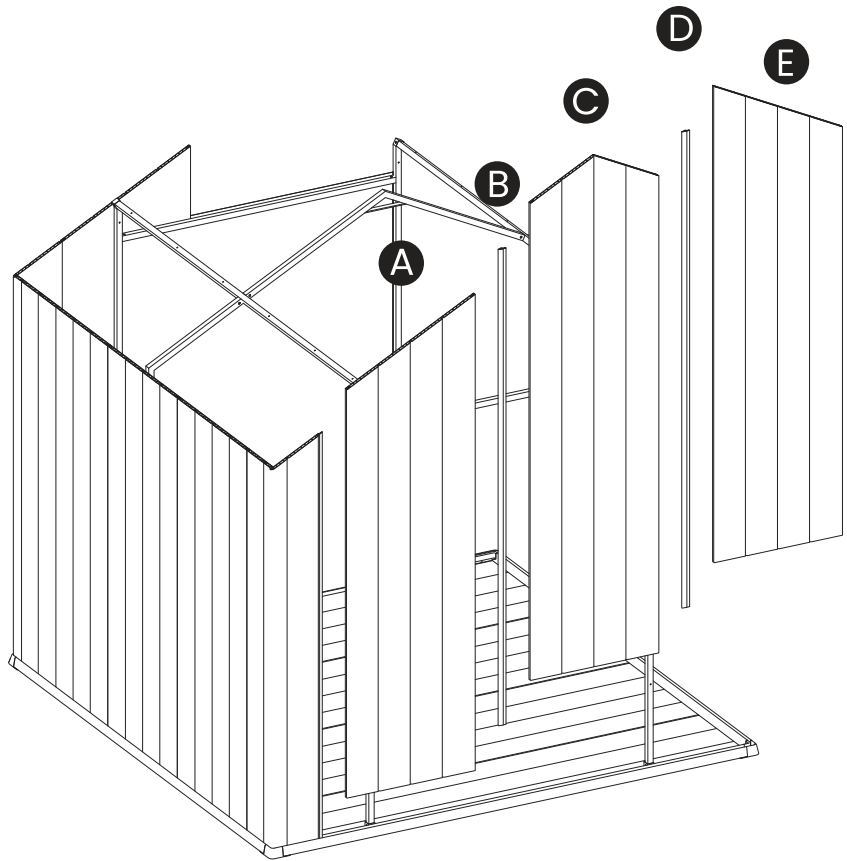
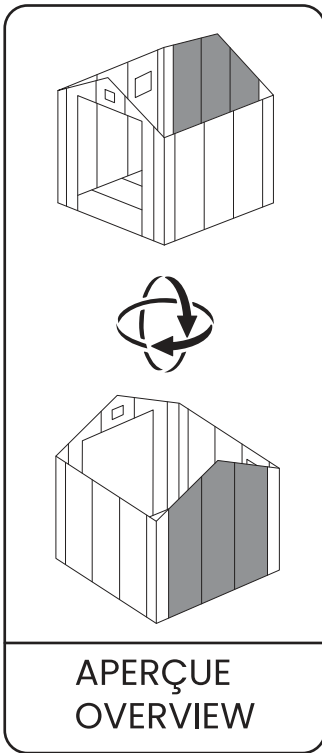

**A** KD110

**B** **D** KD112

**C** KD111

**E** KD109

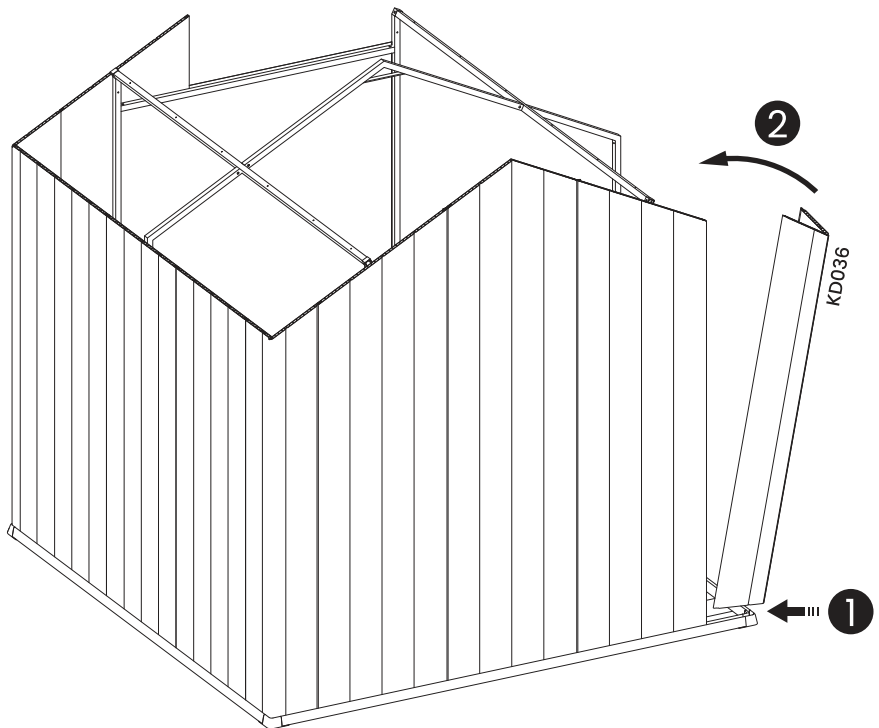
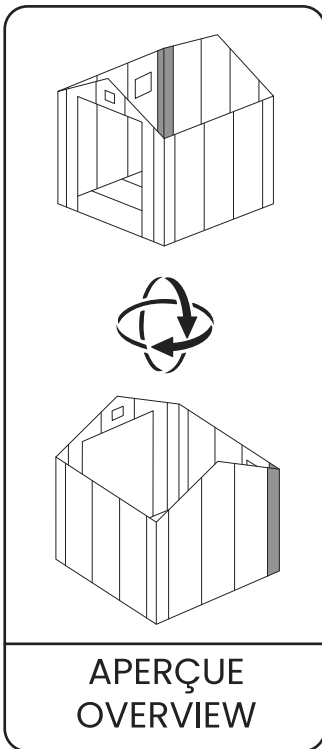

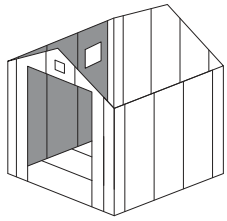

APERÇUE  
OVERVIEW

- A** KD043
- B** KD038
- C** KD043
- D** KD039

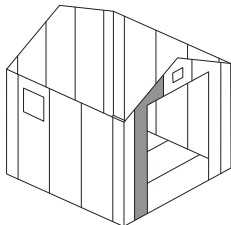
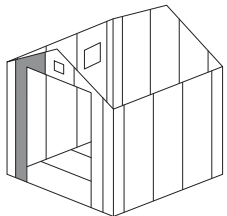
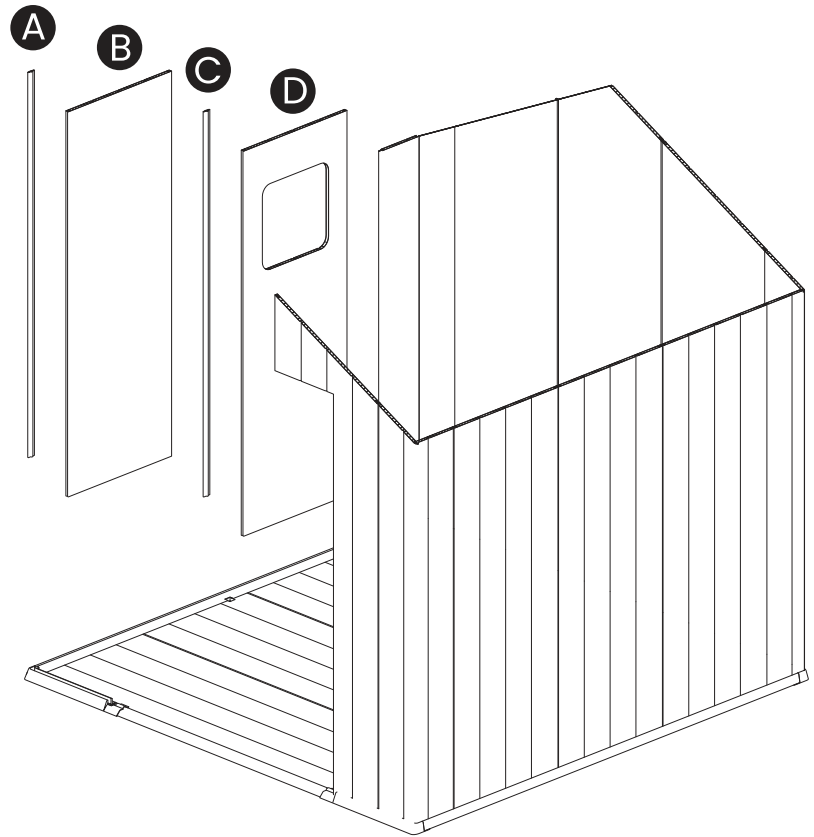

APERÇUE  
OVERVIEW

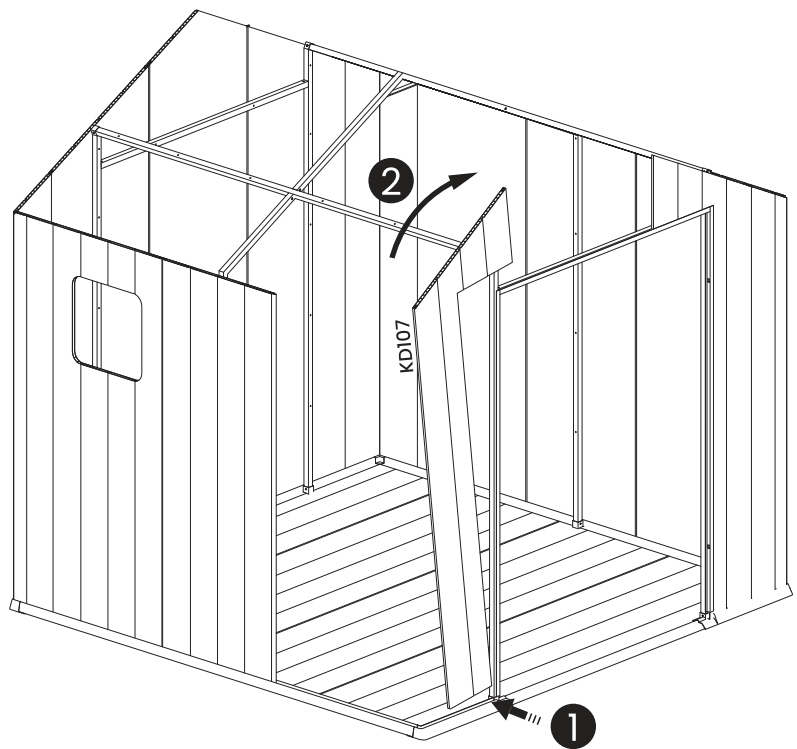

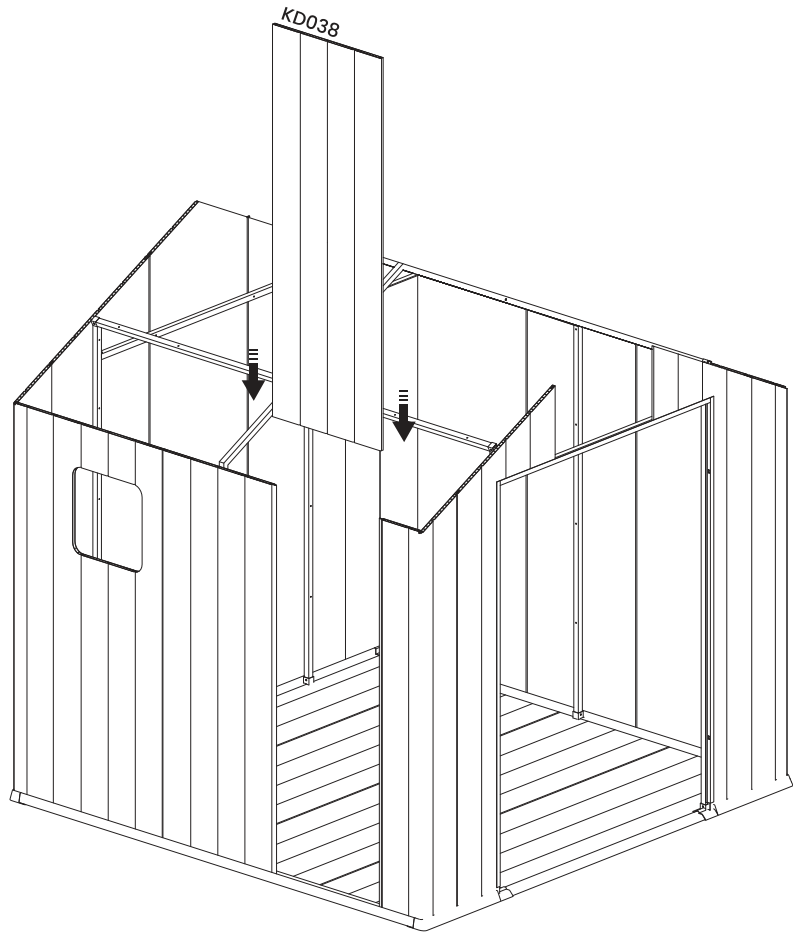
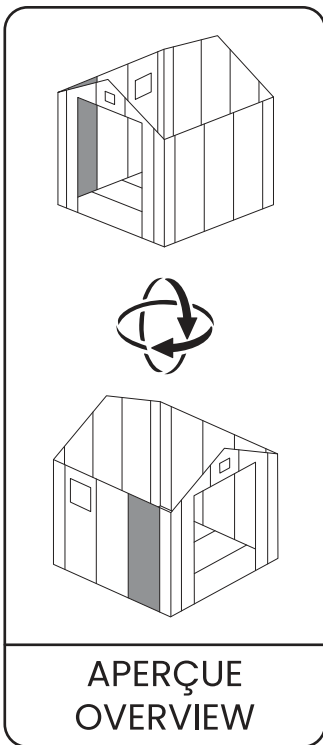
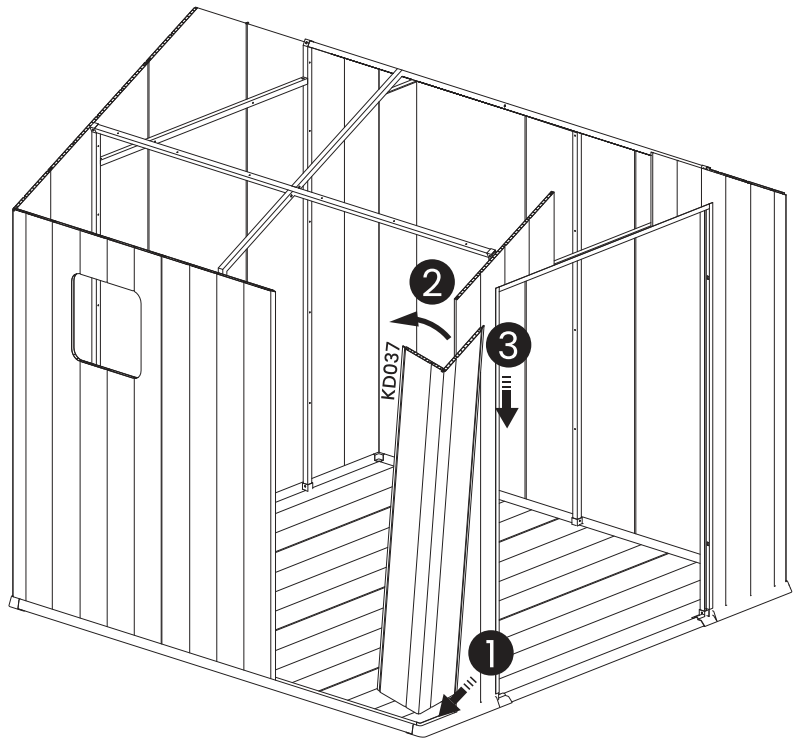
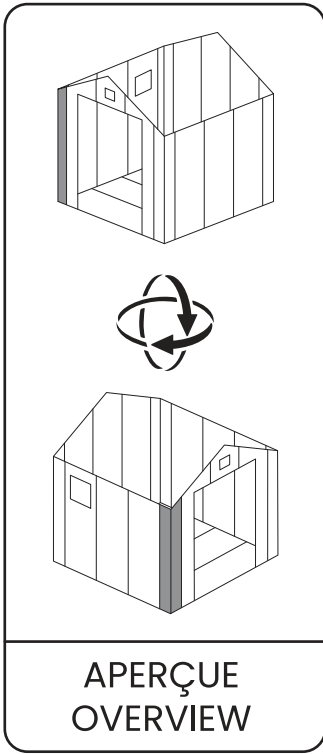

1

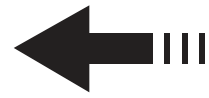
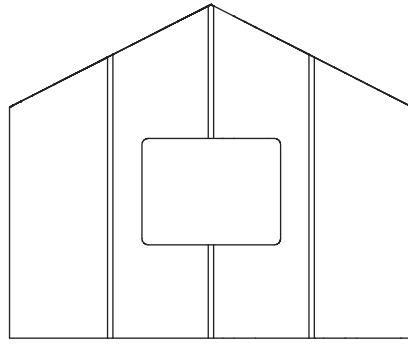
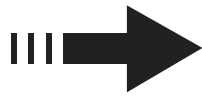

KD042

KD041

KD042

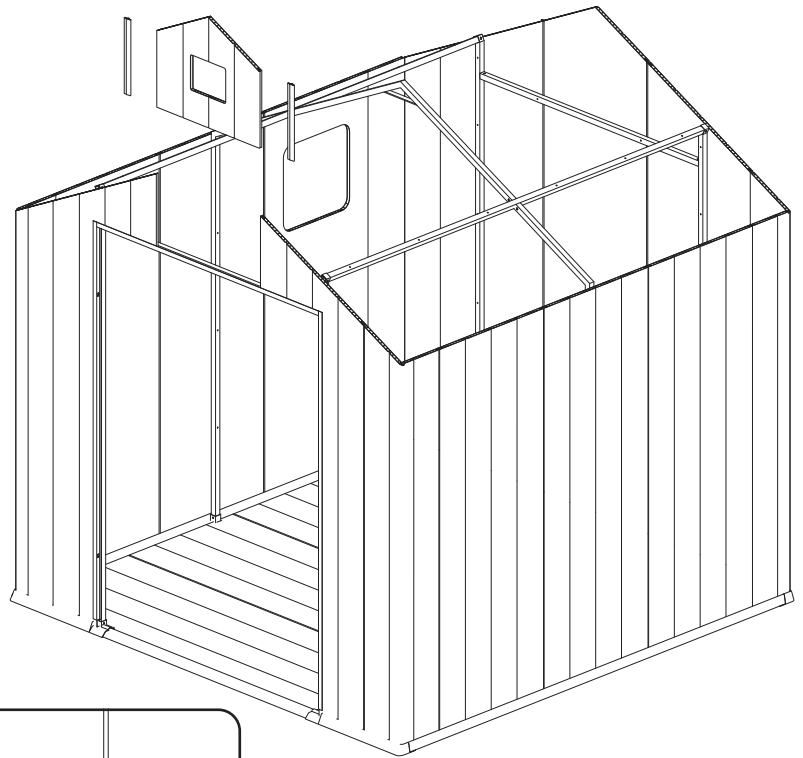

2

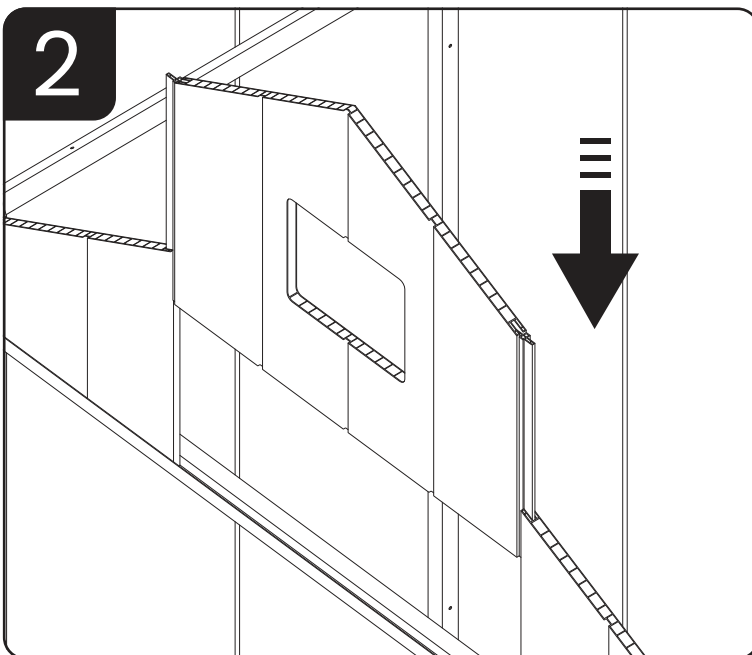



KD084

x8

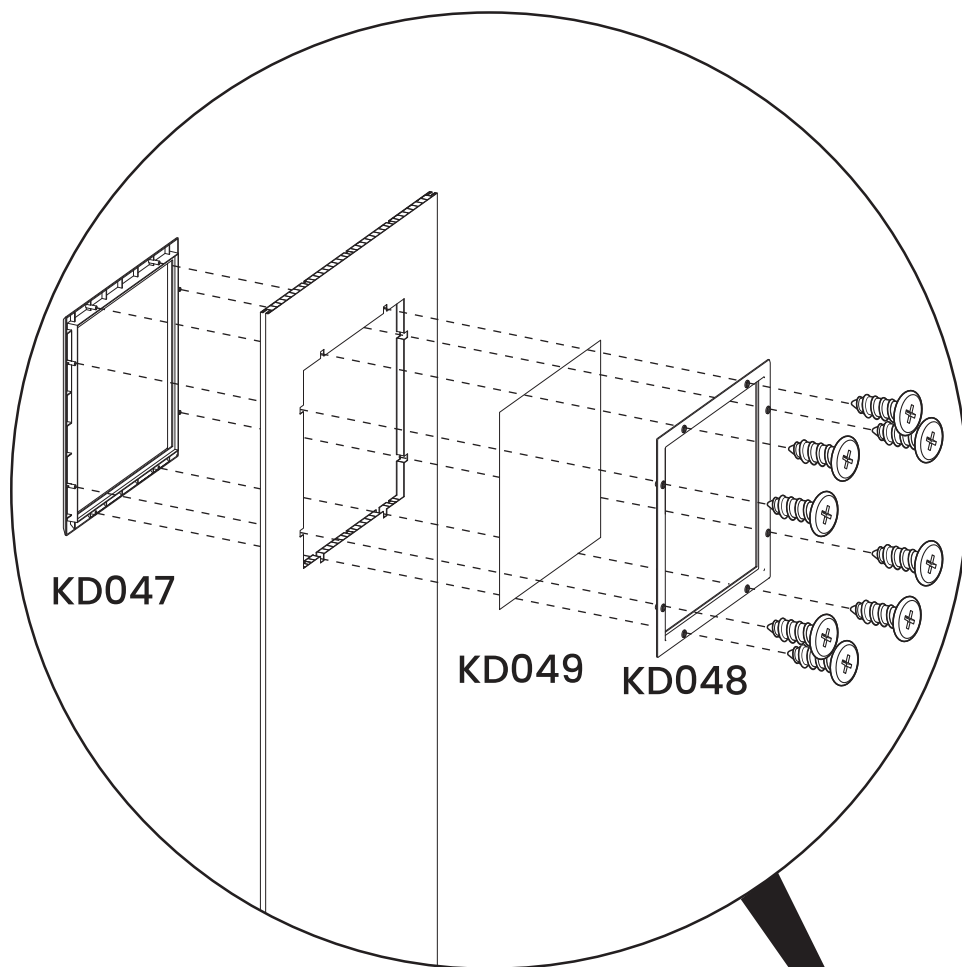

KD047

KD049 KD048

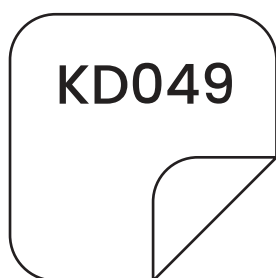

KD049

**Décoller le film. Avant l'installation**  
Peel Off The Film. Before Installation

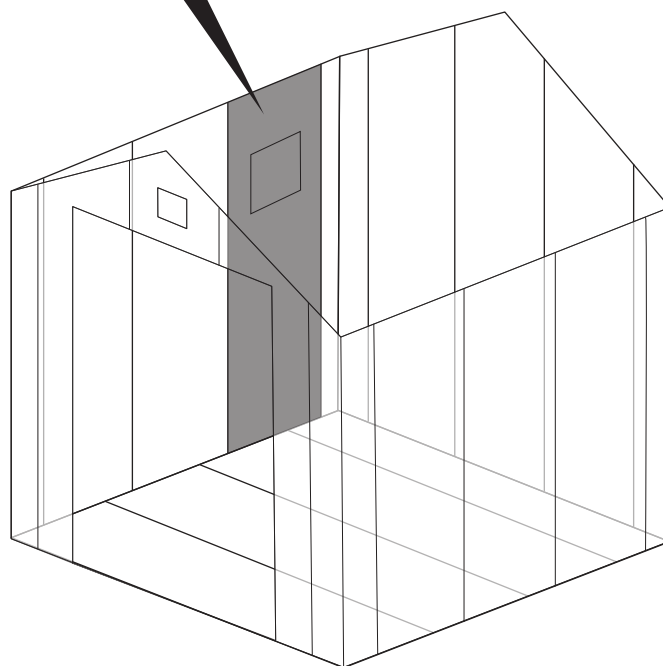

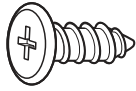

KD083

x18

**Il n'y a pas d'avant-trou proposé. Respectez la distance moyenne.**  
There is no pre-drill hole offered. Keep the distance averagely.

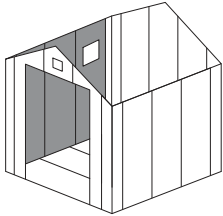

**APERÇU  
OVERVIEW**

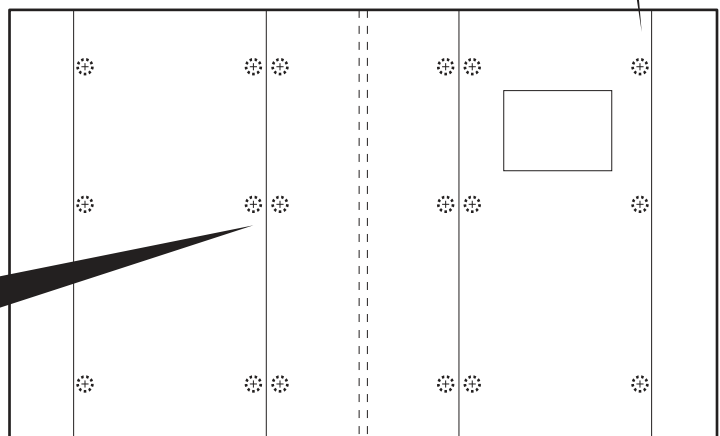
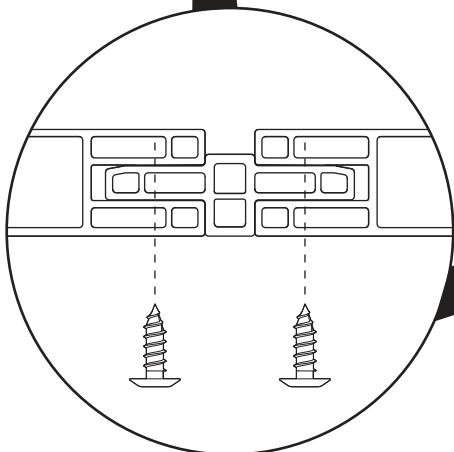
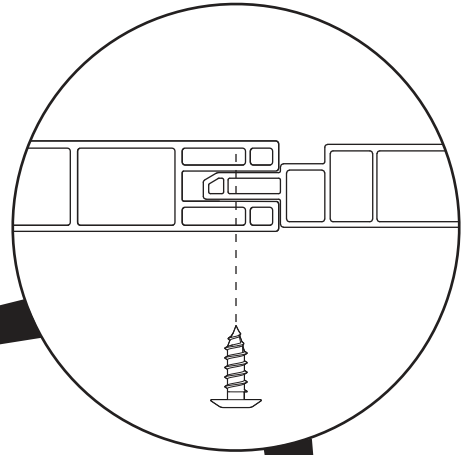
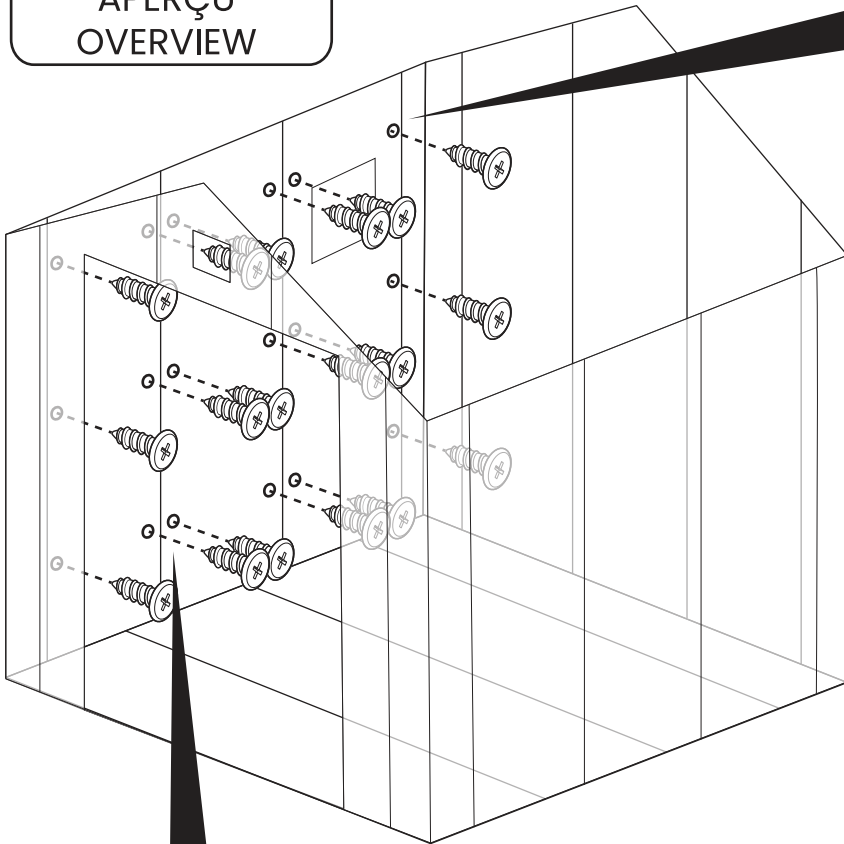

**Vue intérieur projetée**  
Inside Projected View

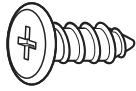

KD083

x18

**Il n'y a pas d'avant-trou proposé. Respectez la distance moyenne.**  
There is no pre-drill hole offered. Keep the distance averagely.

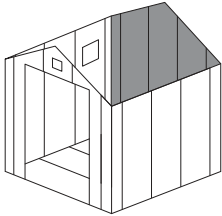

**APERÇU  
OVERVIEW**

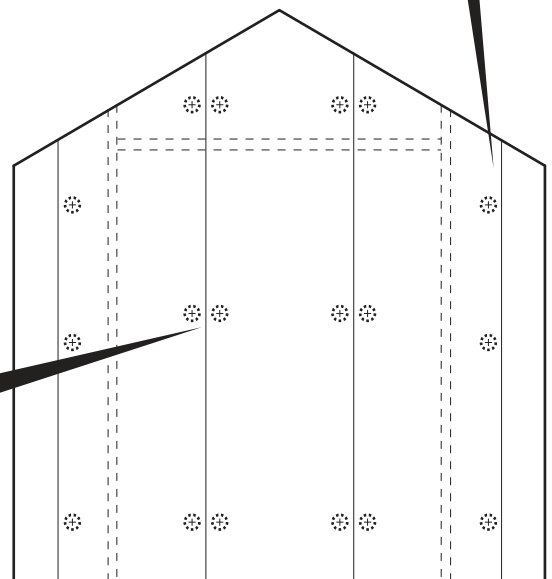
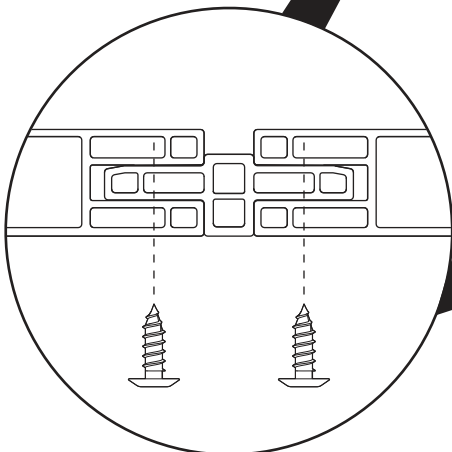
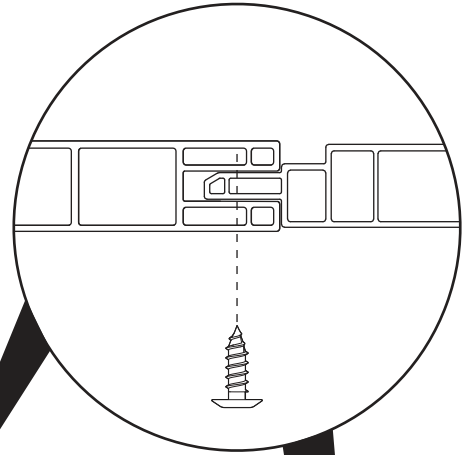
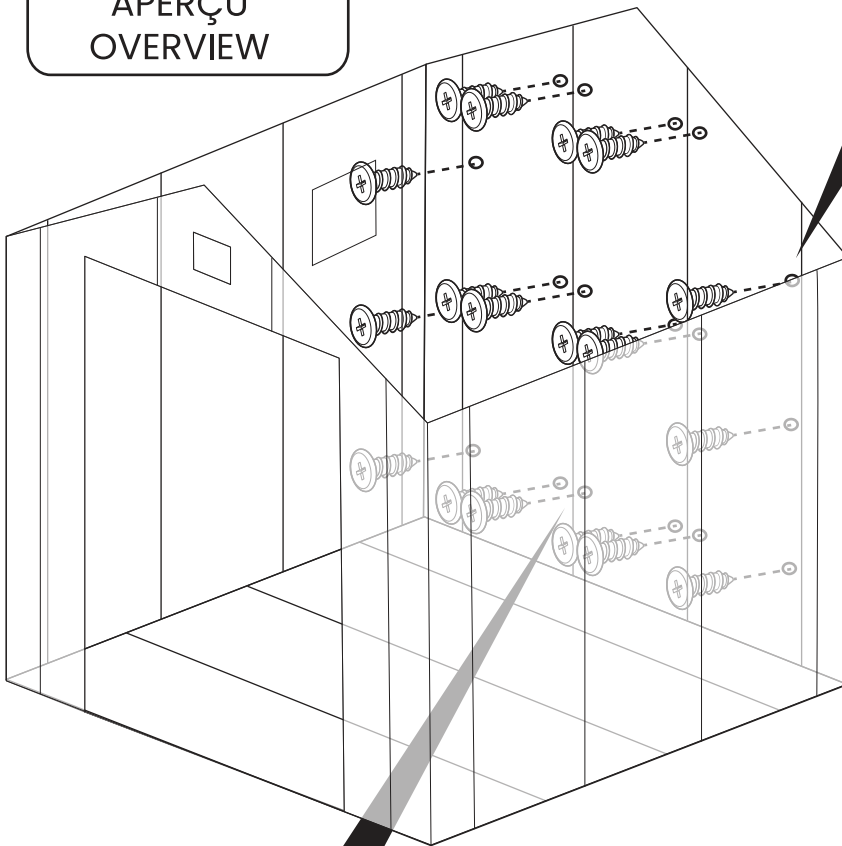

**Vue intérieure projetée**  
Inside Projected View



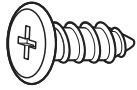

KD083

x18

Il n'y a pas d'avant-trou proposé. Respectez une distance moyenne.

There is no pre-drill hole offered. Keep the distance averagely.

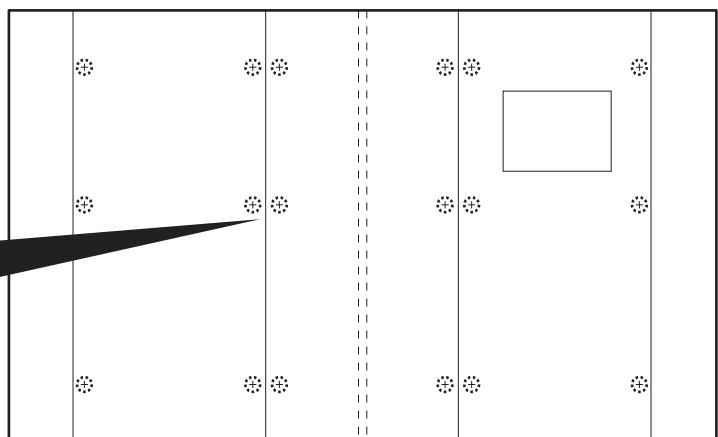
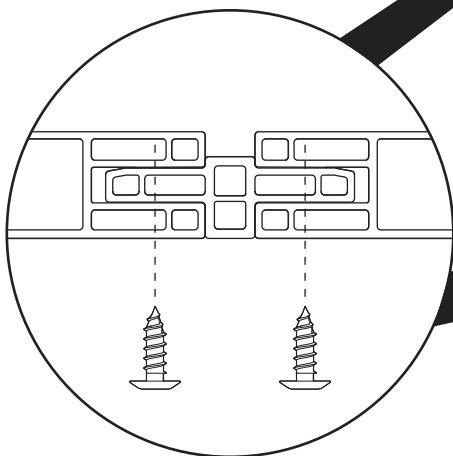
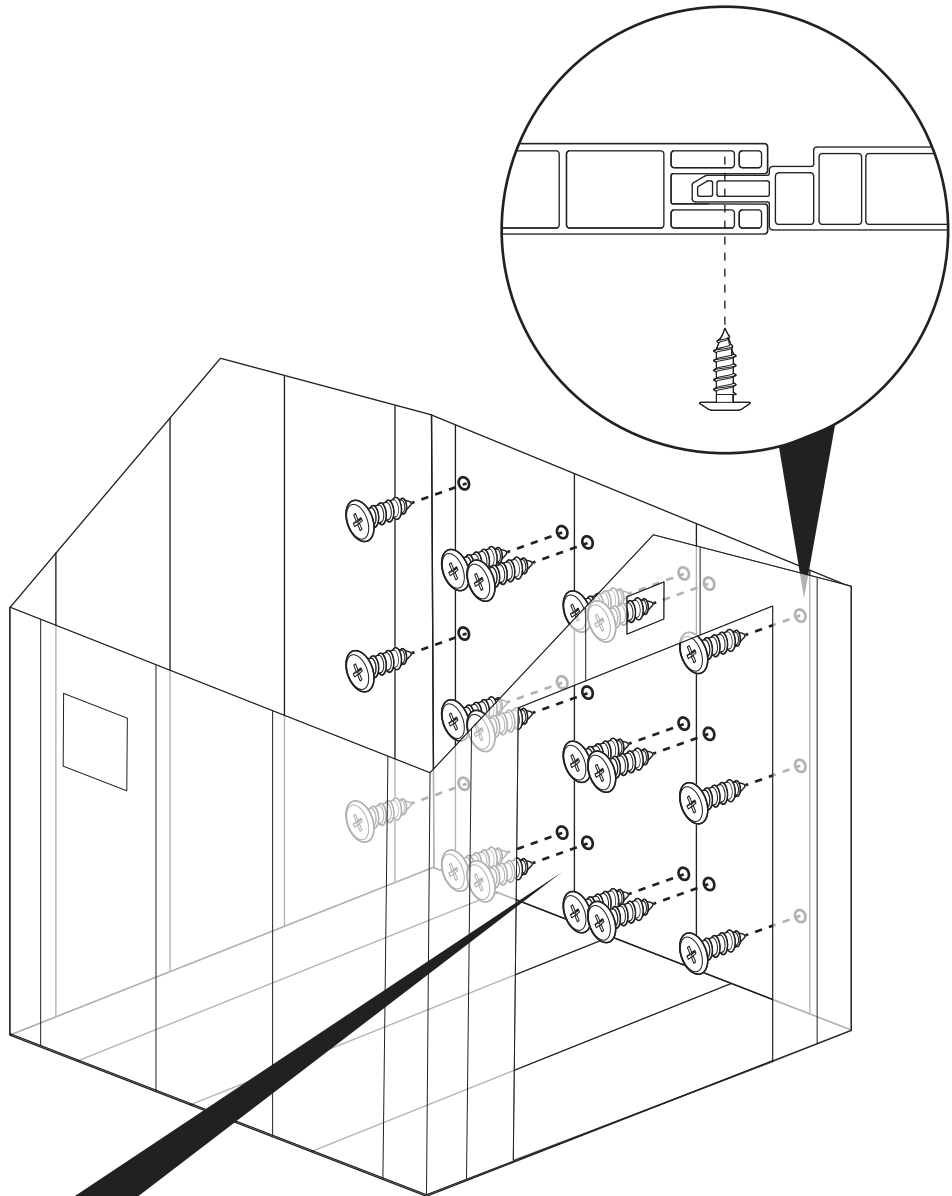
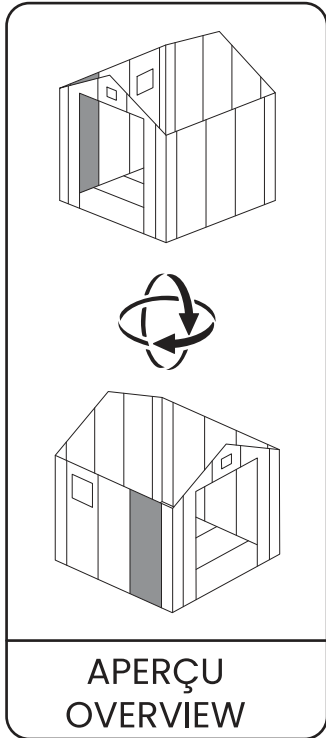

Vue intérieur projetée / Inside Projected View

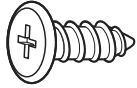

KD083

x10

Il n'y a pas d'avant-trou proposé. Respectez une distance moyenne.  
There is no pre-drill hole offered. Keep the distance averagely.

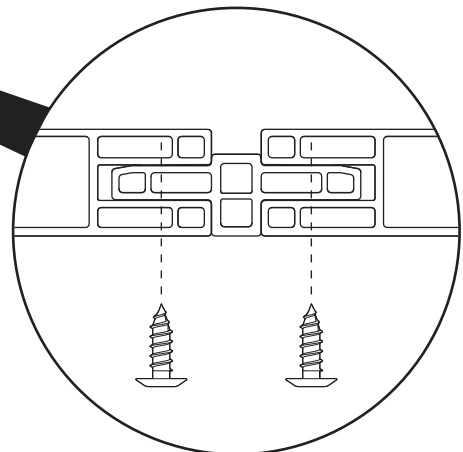
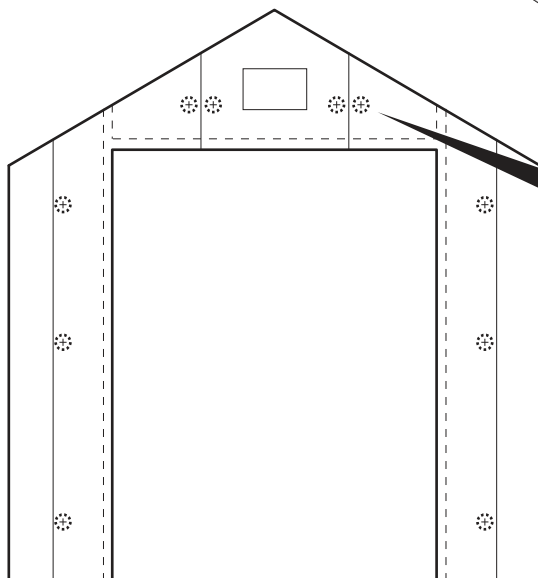
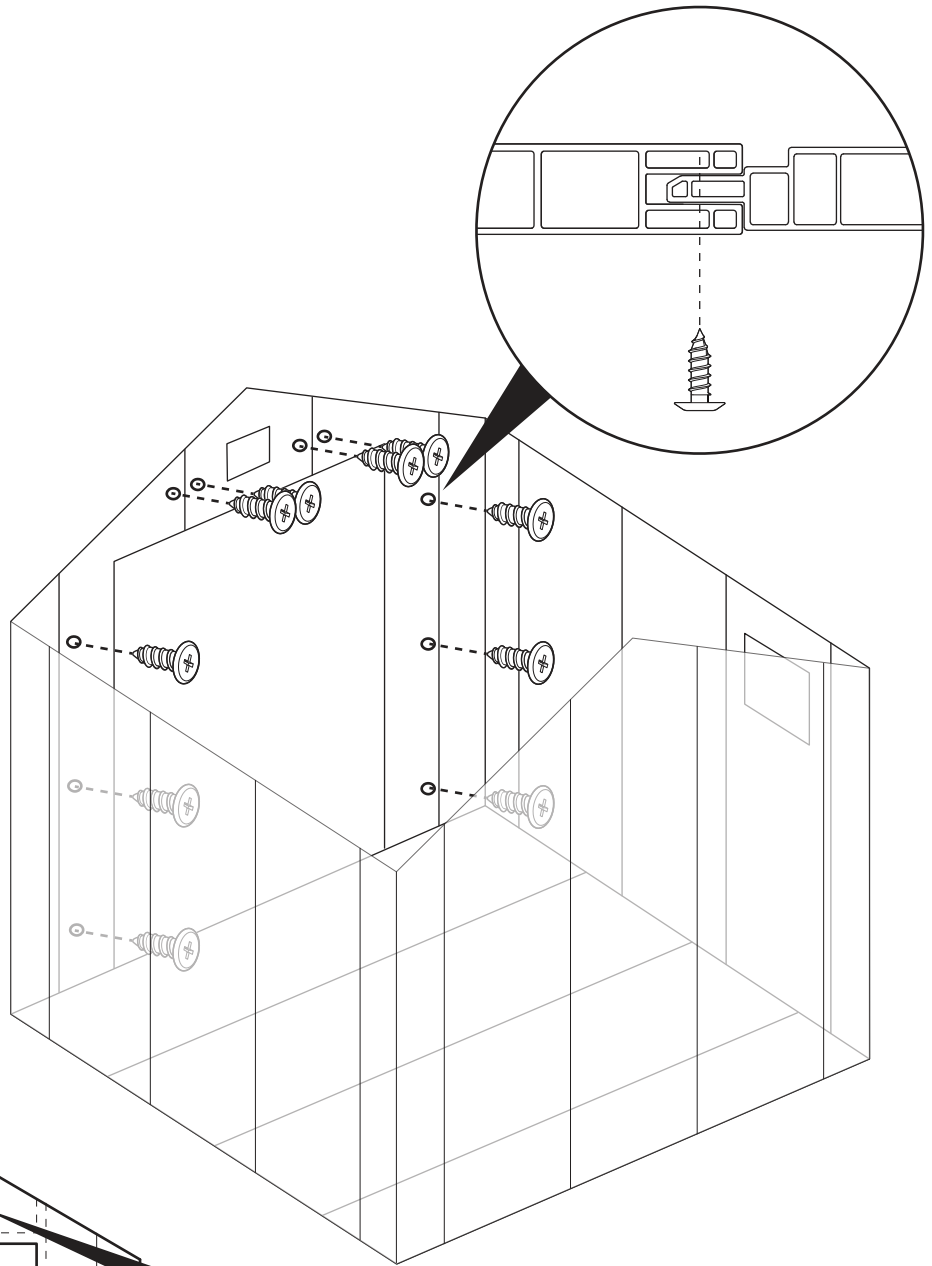
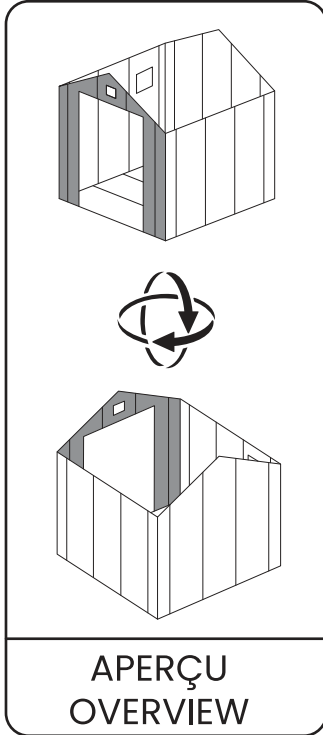

Vue intérieur projetée / Inside Projected View



# Assemblage du toit

## Roof Assembly

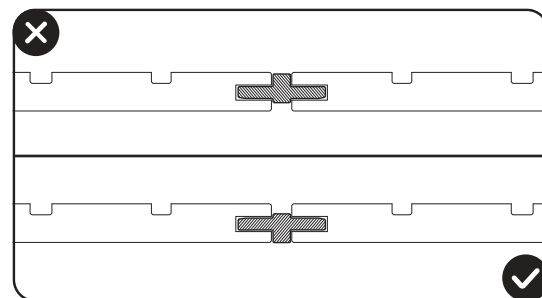
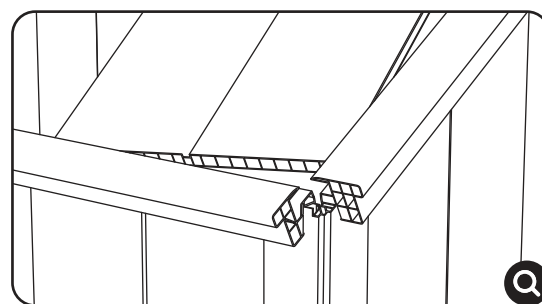
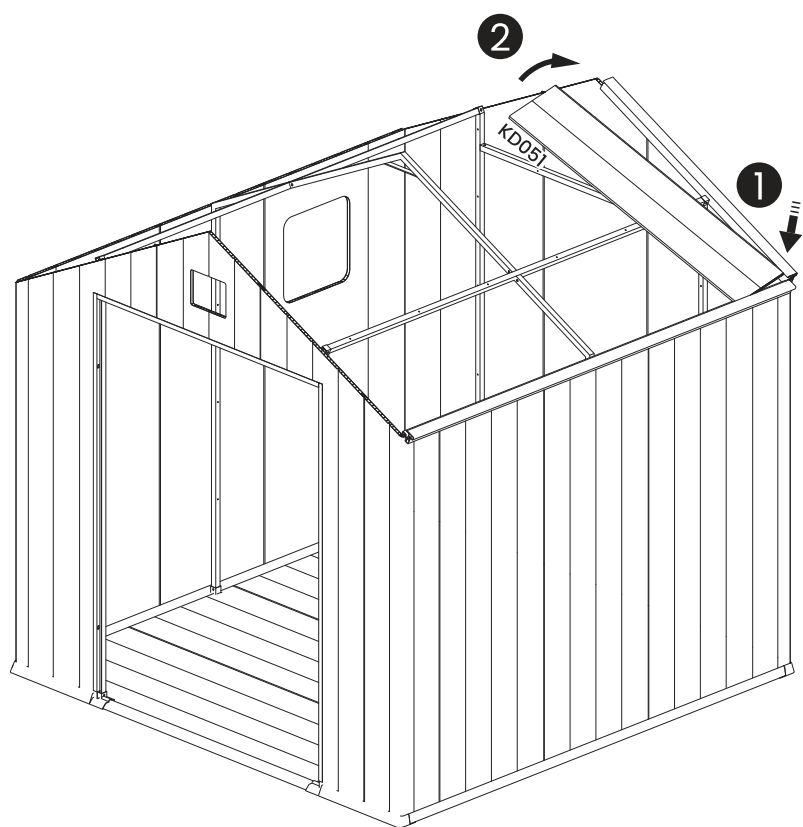
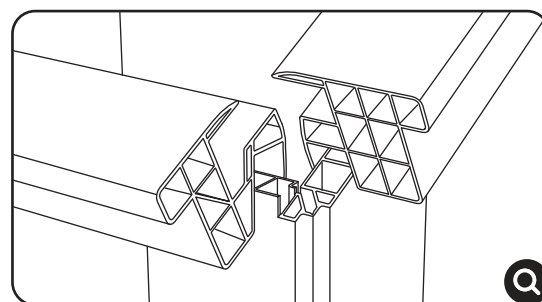
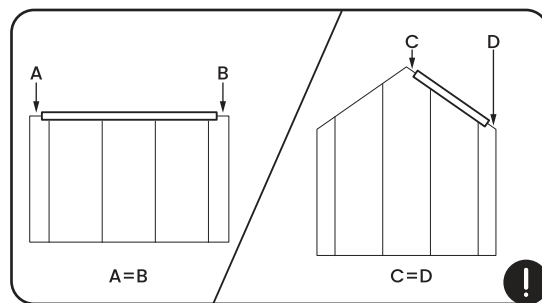
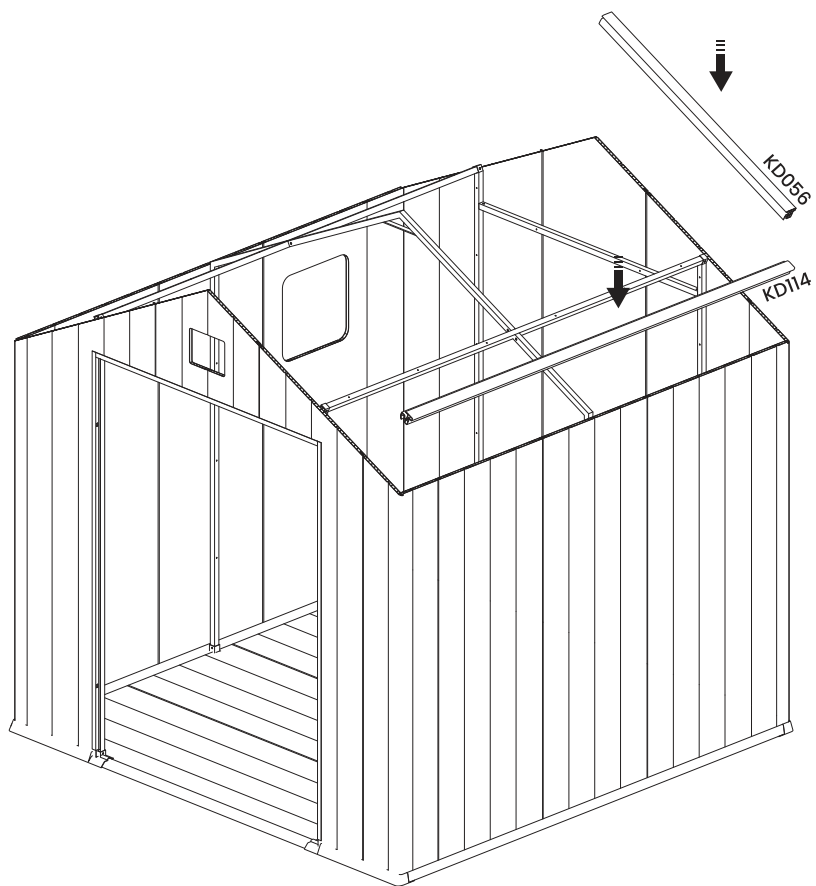

Étape 1 / Step 1

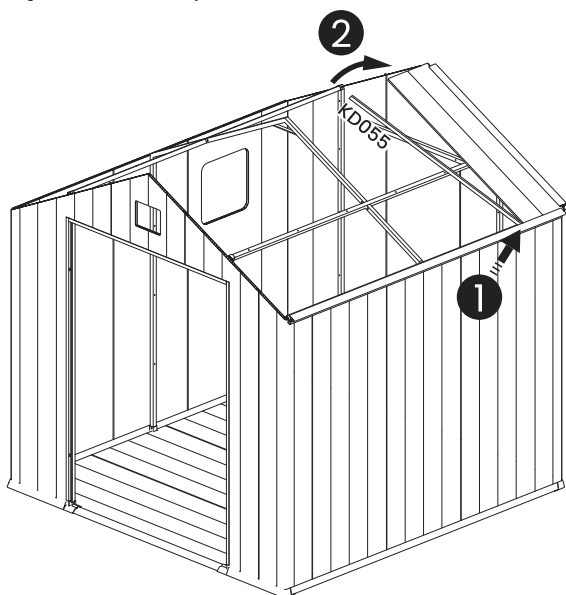

Étape 2 / Step 2

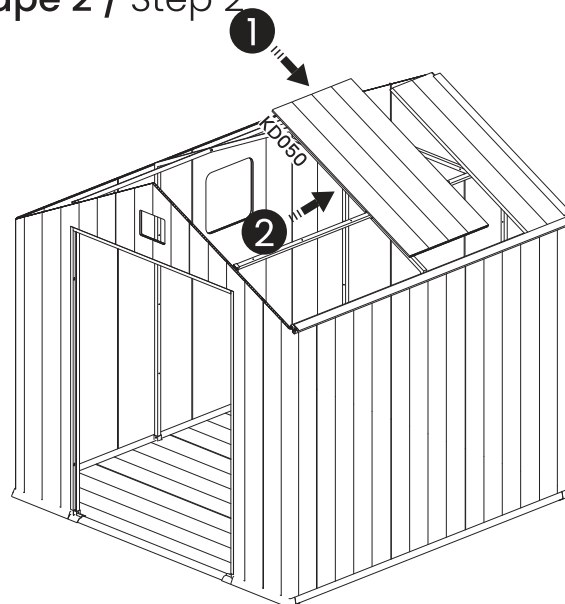

Étape 3 / Step 3

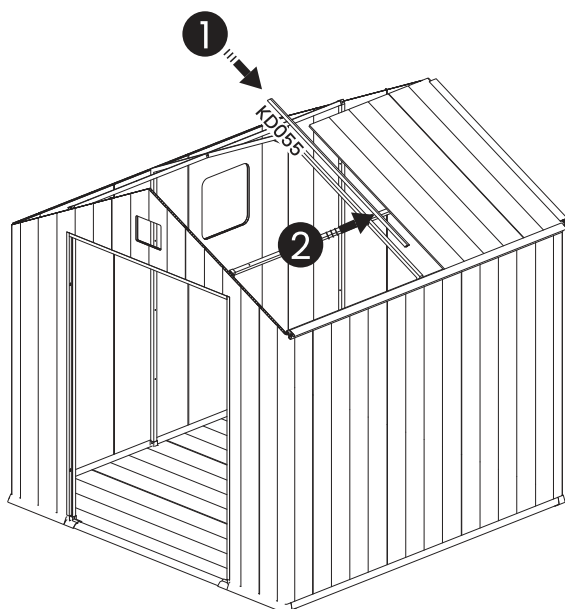

Étape 4 / Step 4

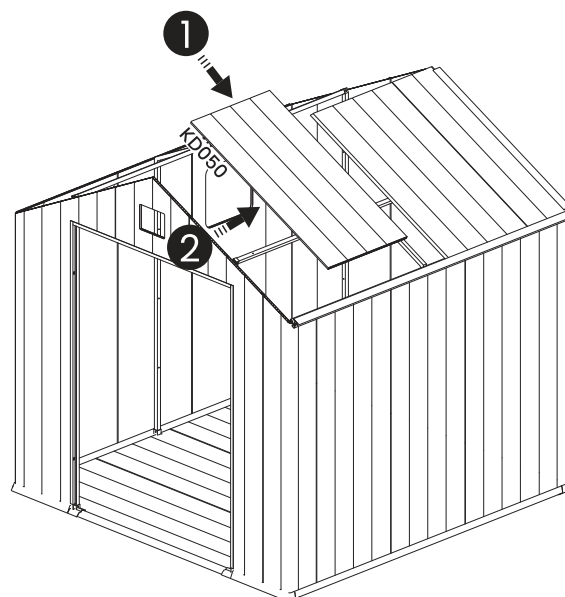

Étape 5 / Step 5

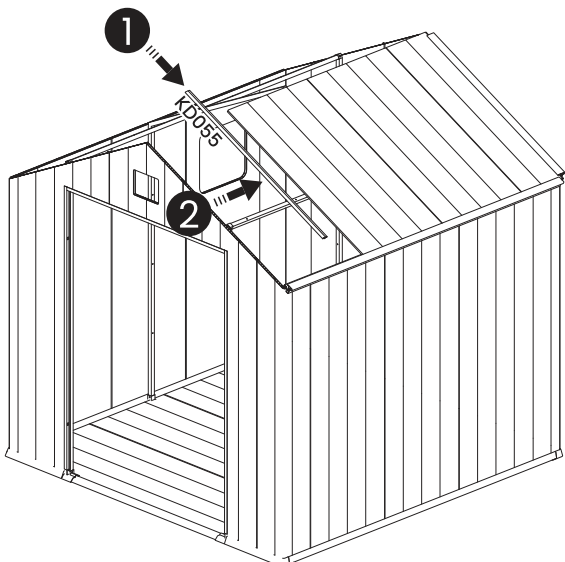

Étape 6 / Step 6

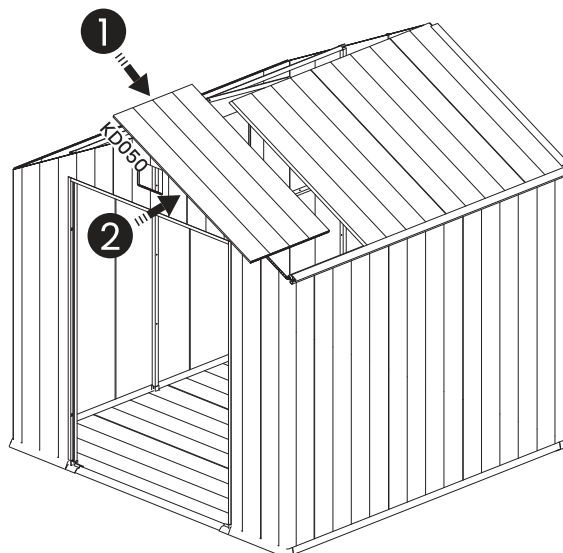

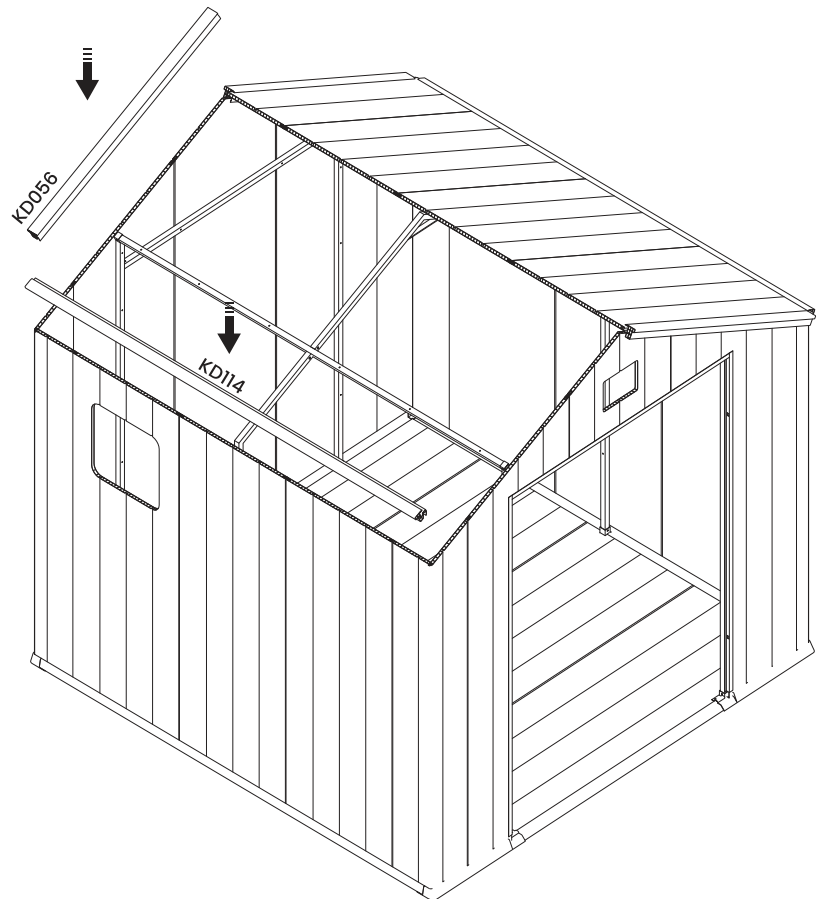
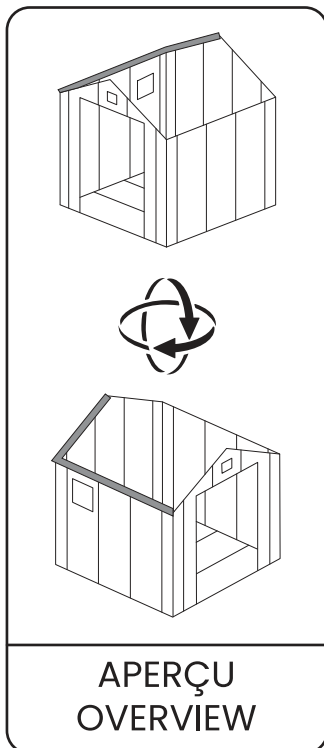
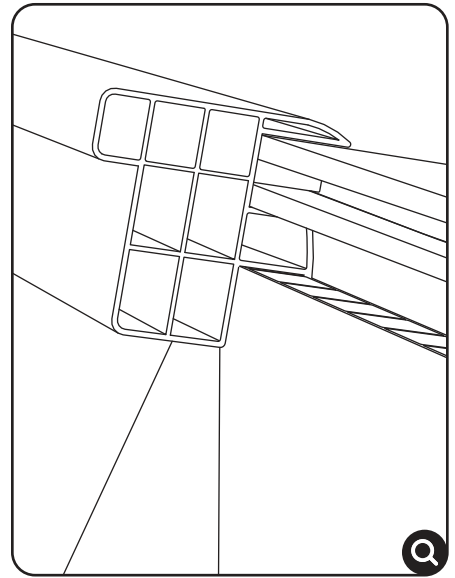
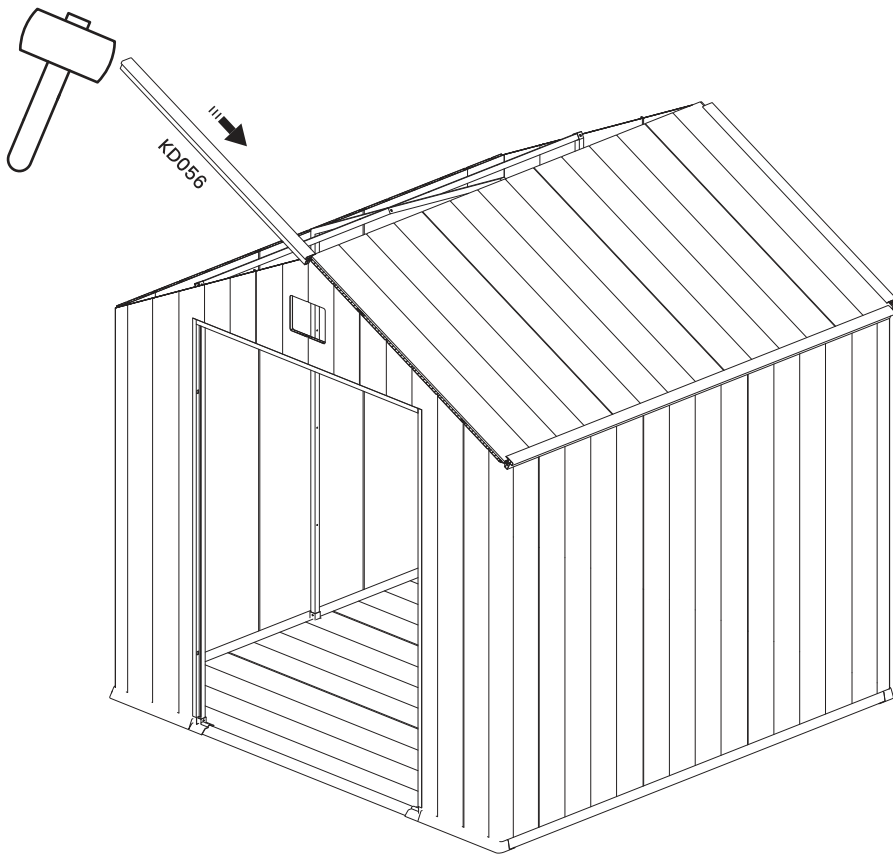

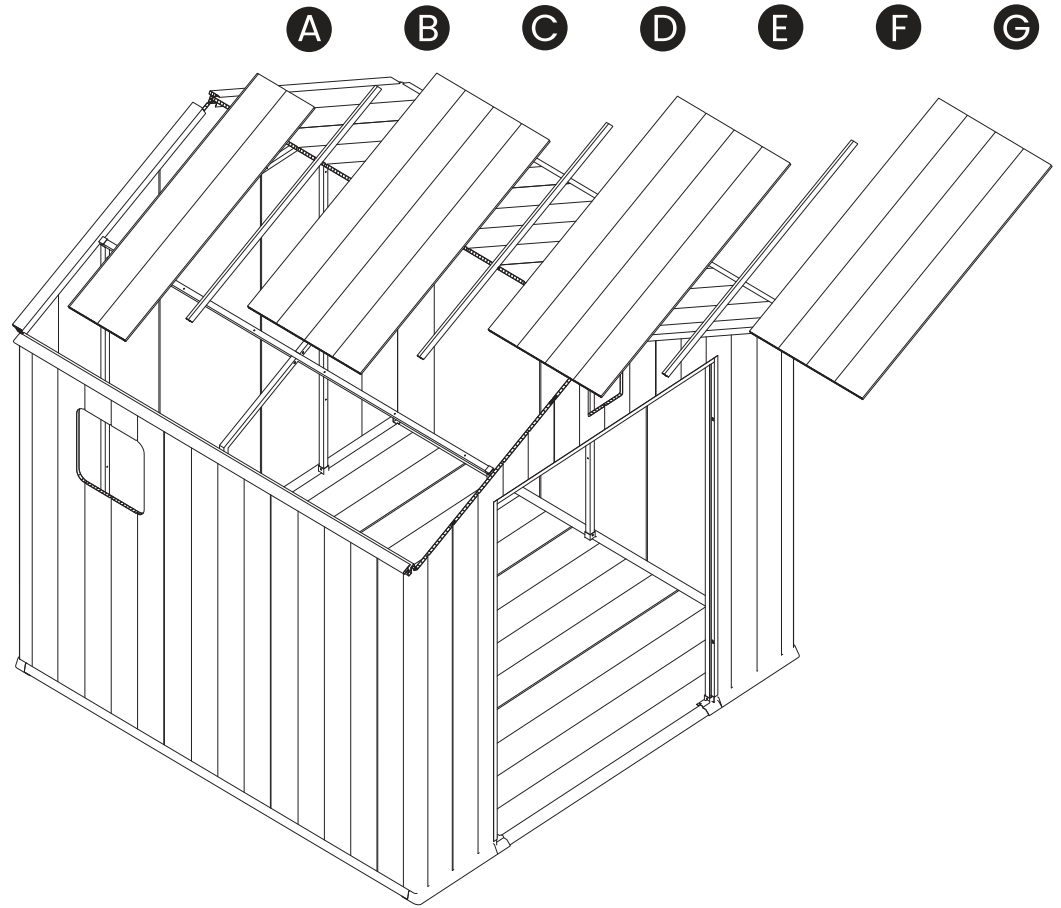
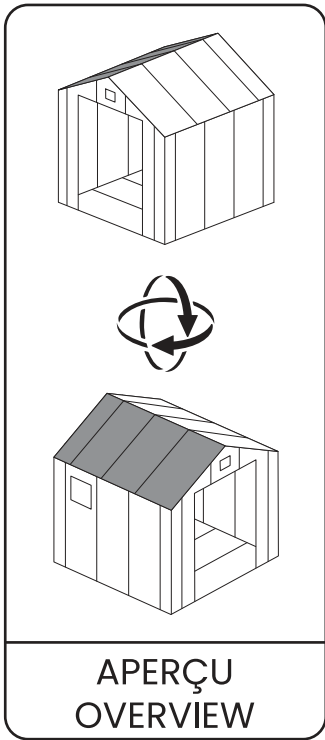

**A** KD051                      **B D F** KD055                      **C E G** KD050

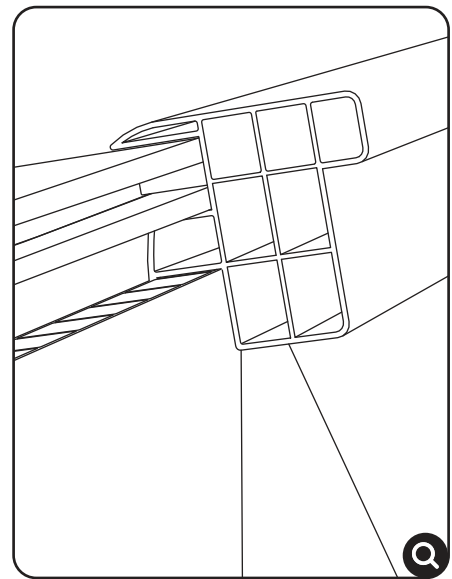
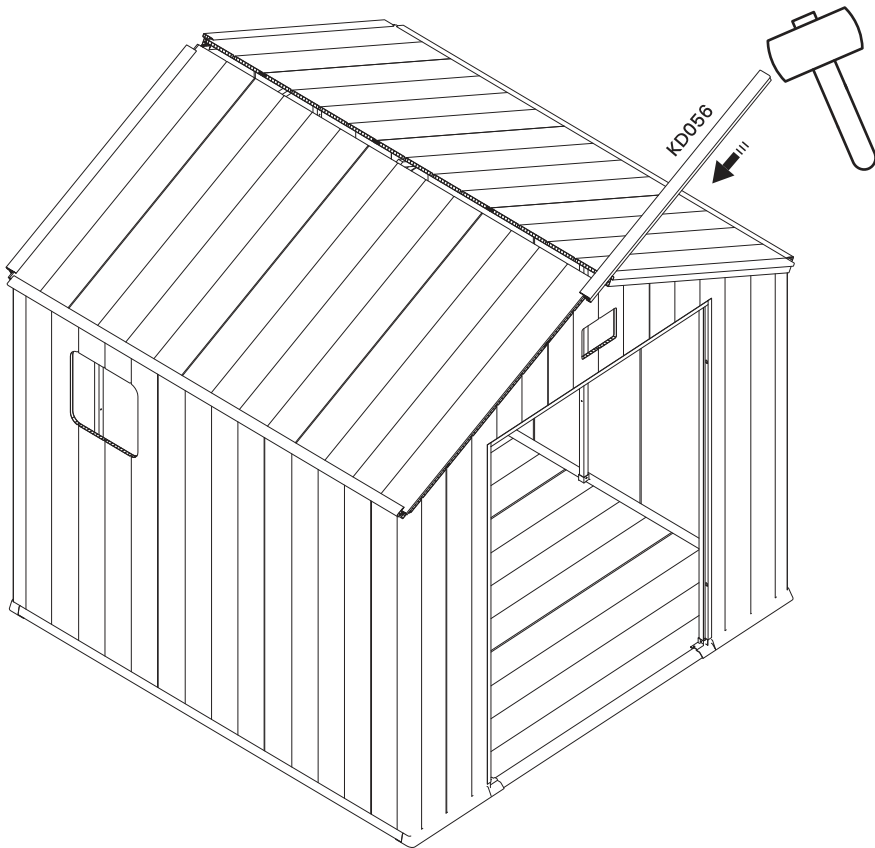

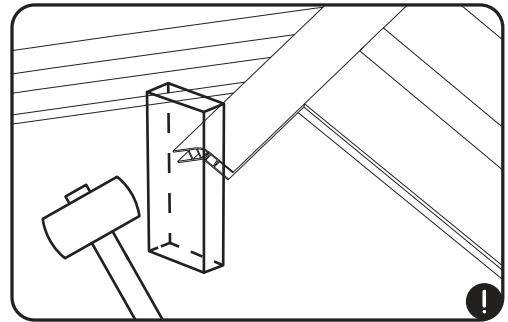
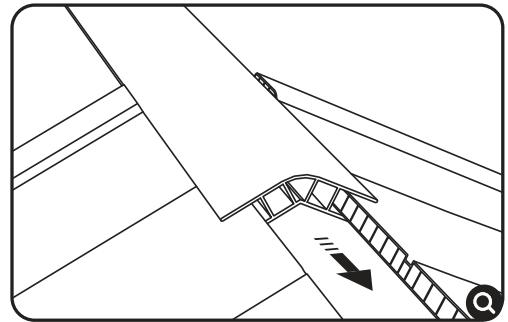
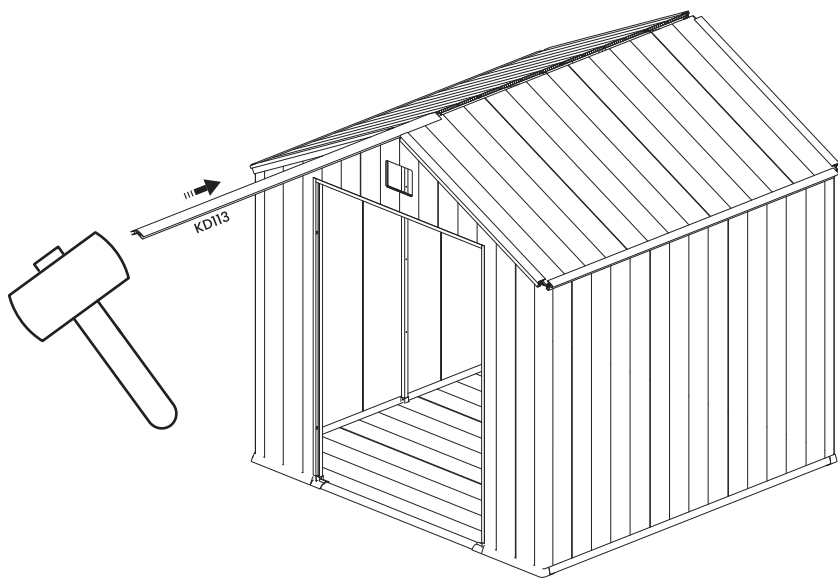

Utiliser le KD120 pour protéger la pièce.  
Use the KD120 to protect the part.

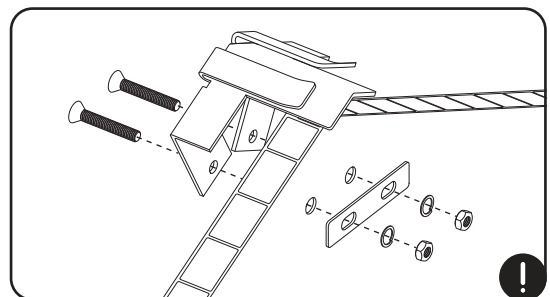
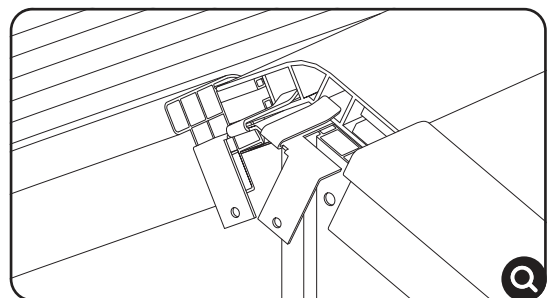
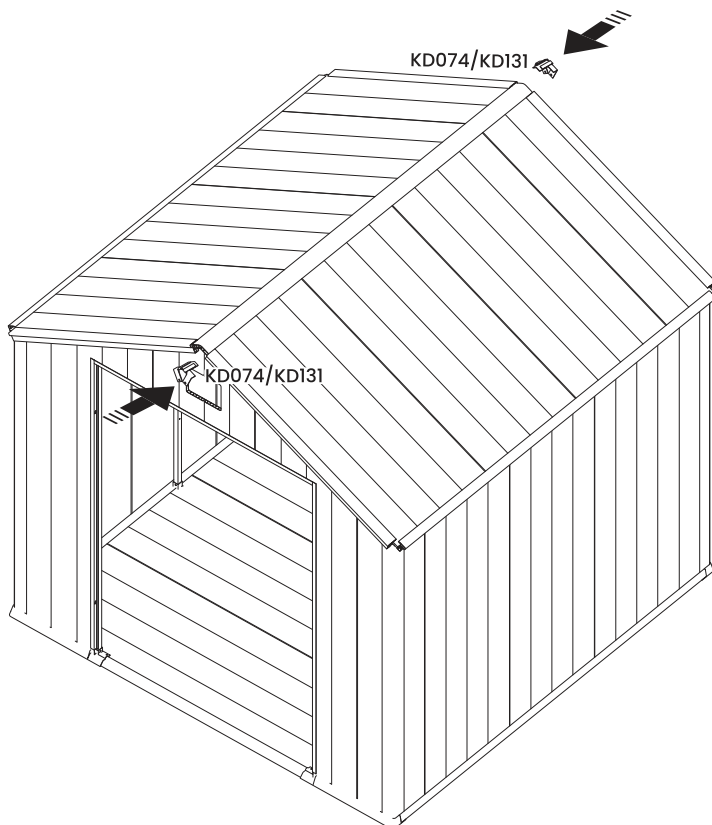



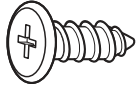

KD083

x24

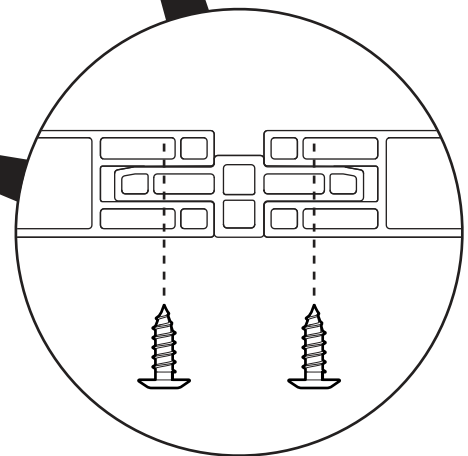
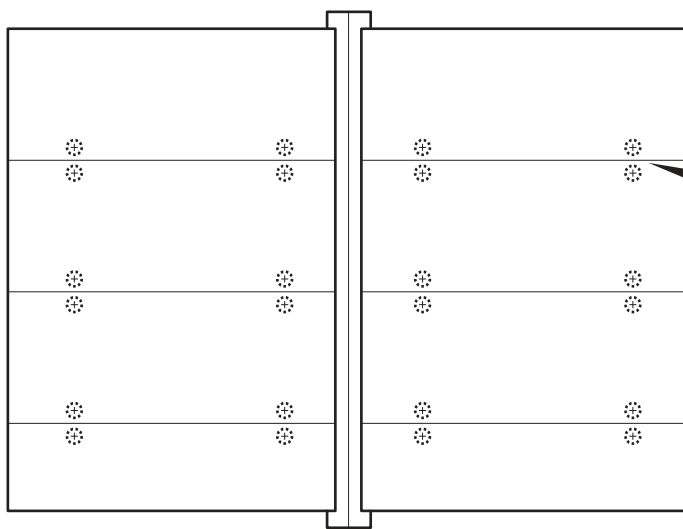
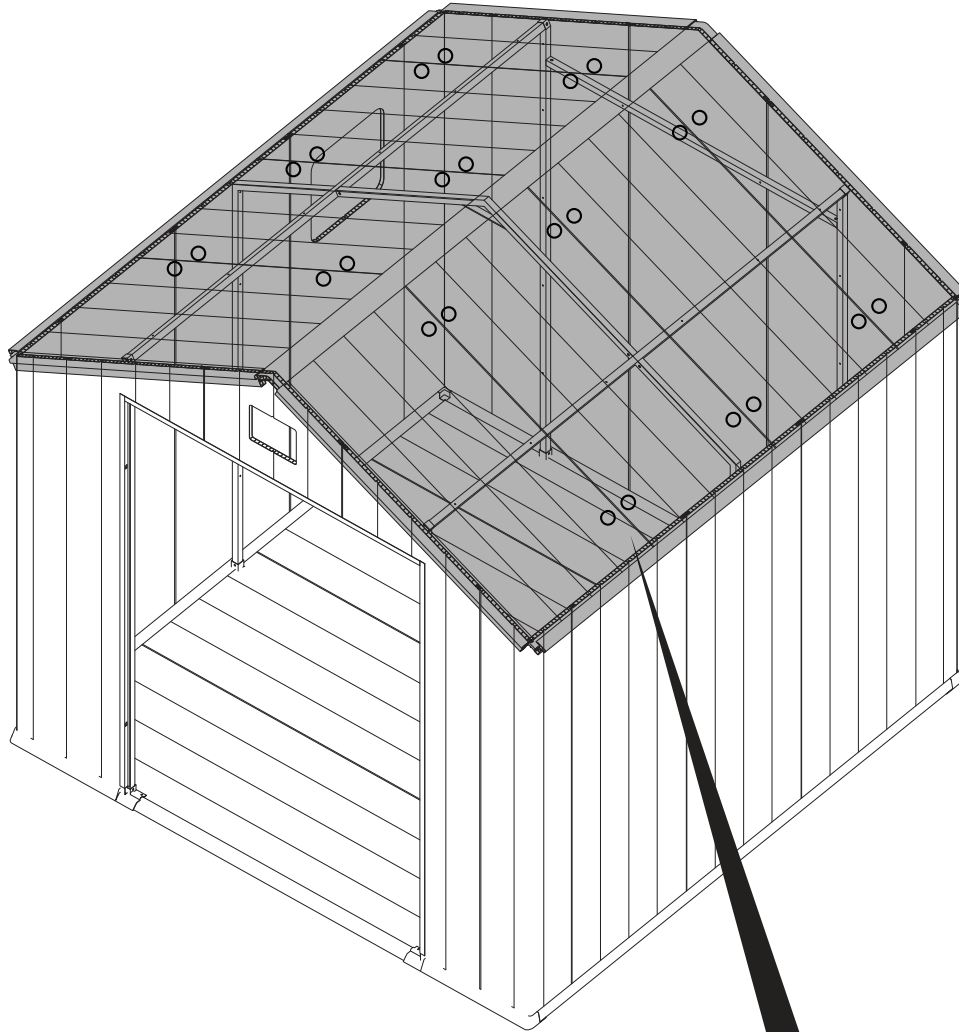

Vue intérieure projetée / Inside Projected View

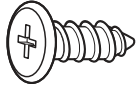

KD083

x12

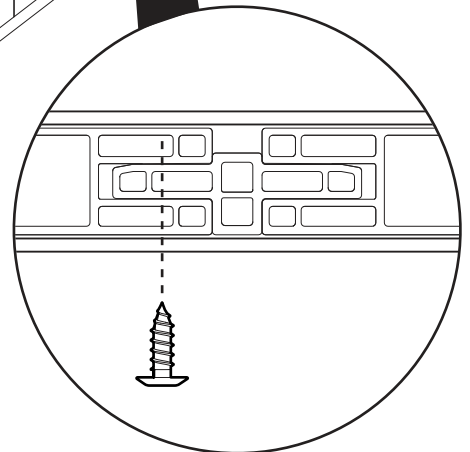
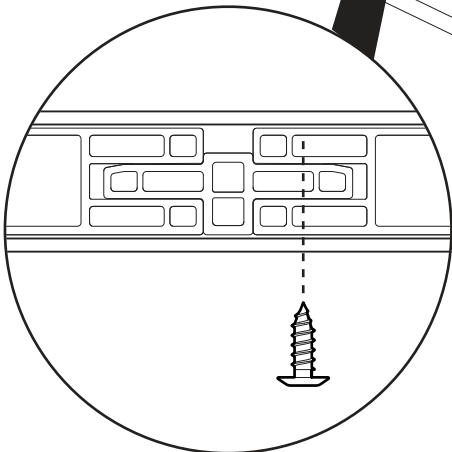
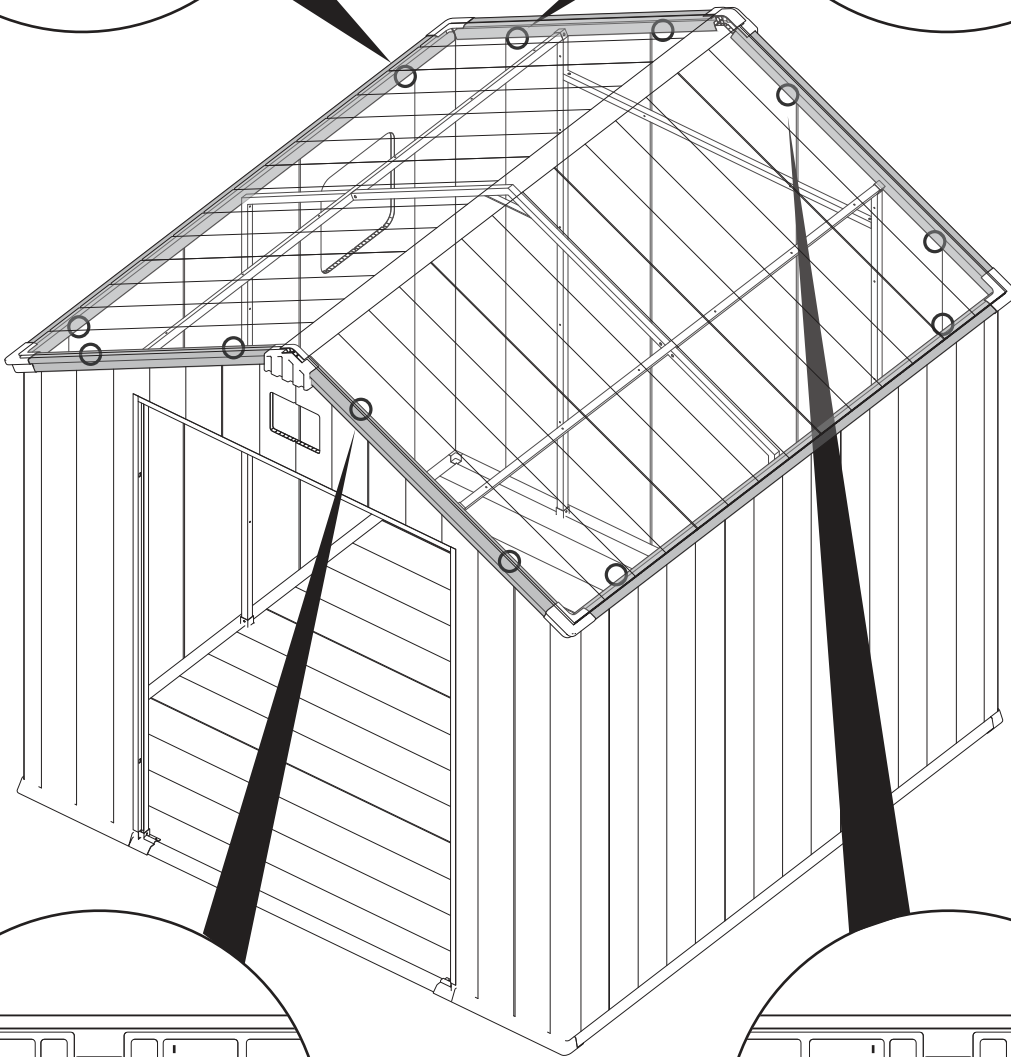
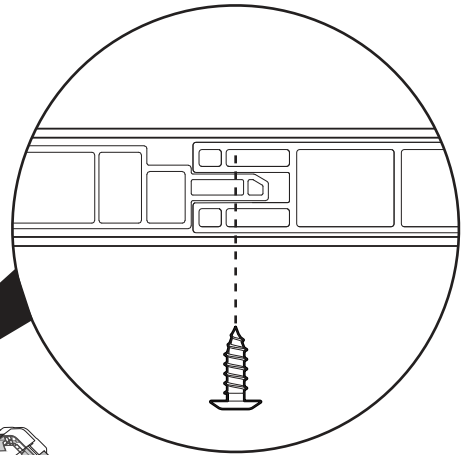
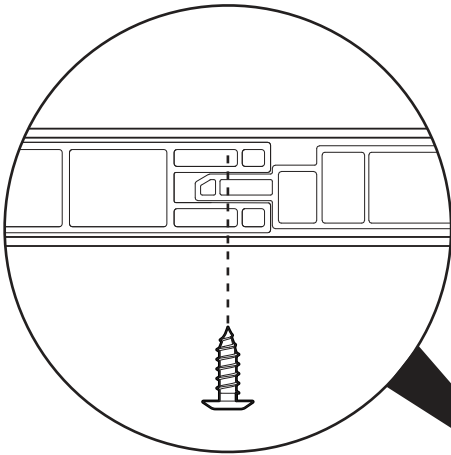

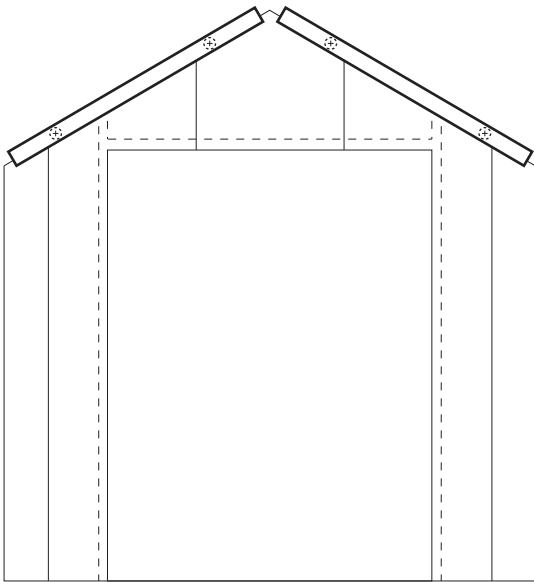

Vue intérieure avant / Front Inside View

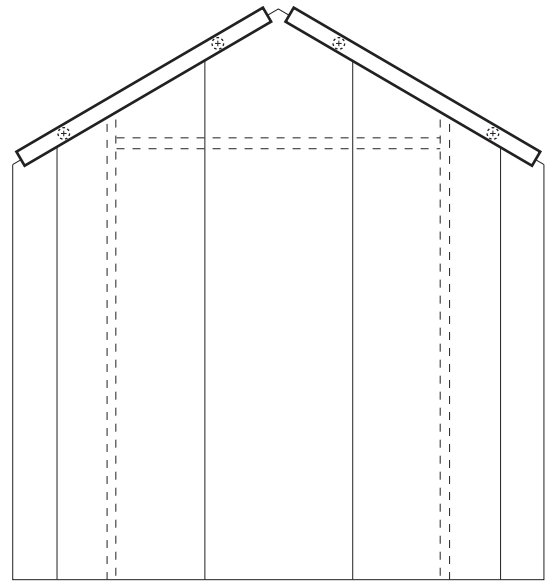

Vue intérieure arrière / Back Inside View

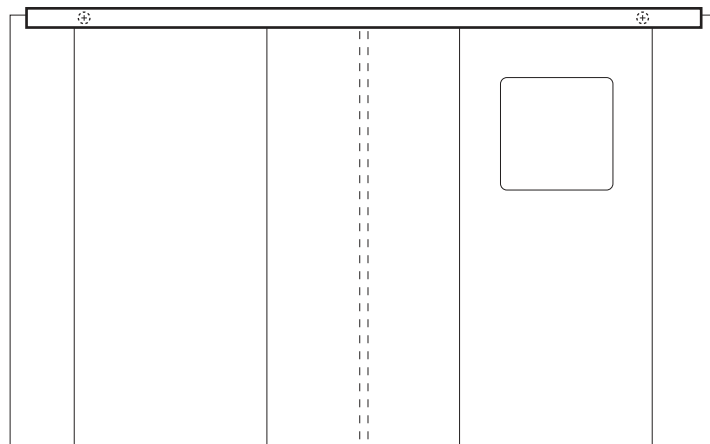

Vue intérieure gauche / Left Inside View

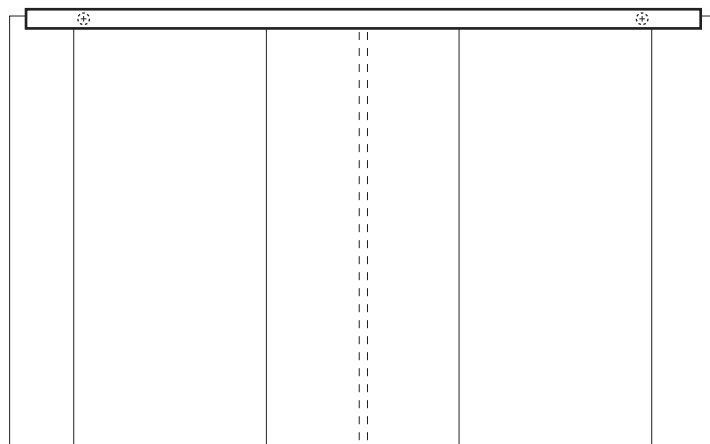

Vue intérieure droite / Right Inside View

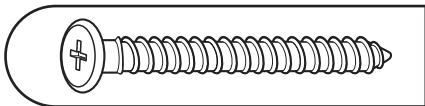

KD085

x12

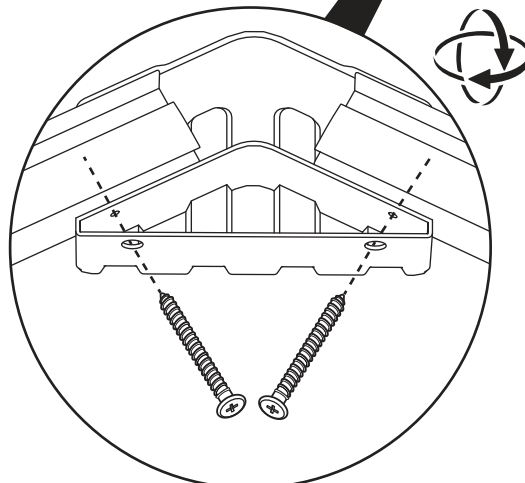
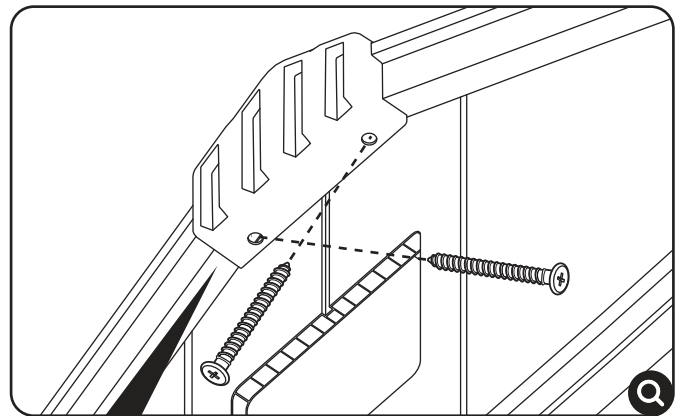
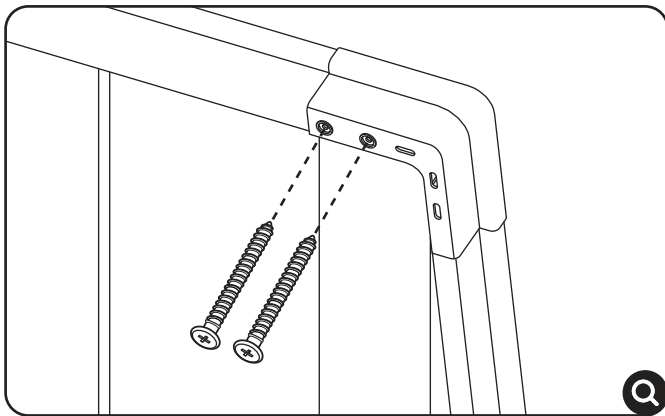
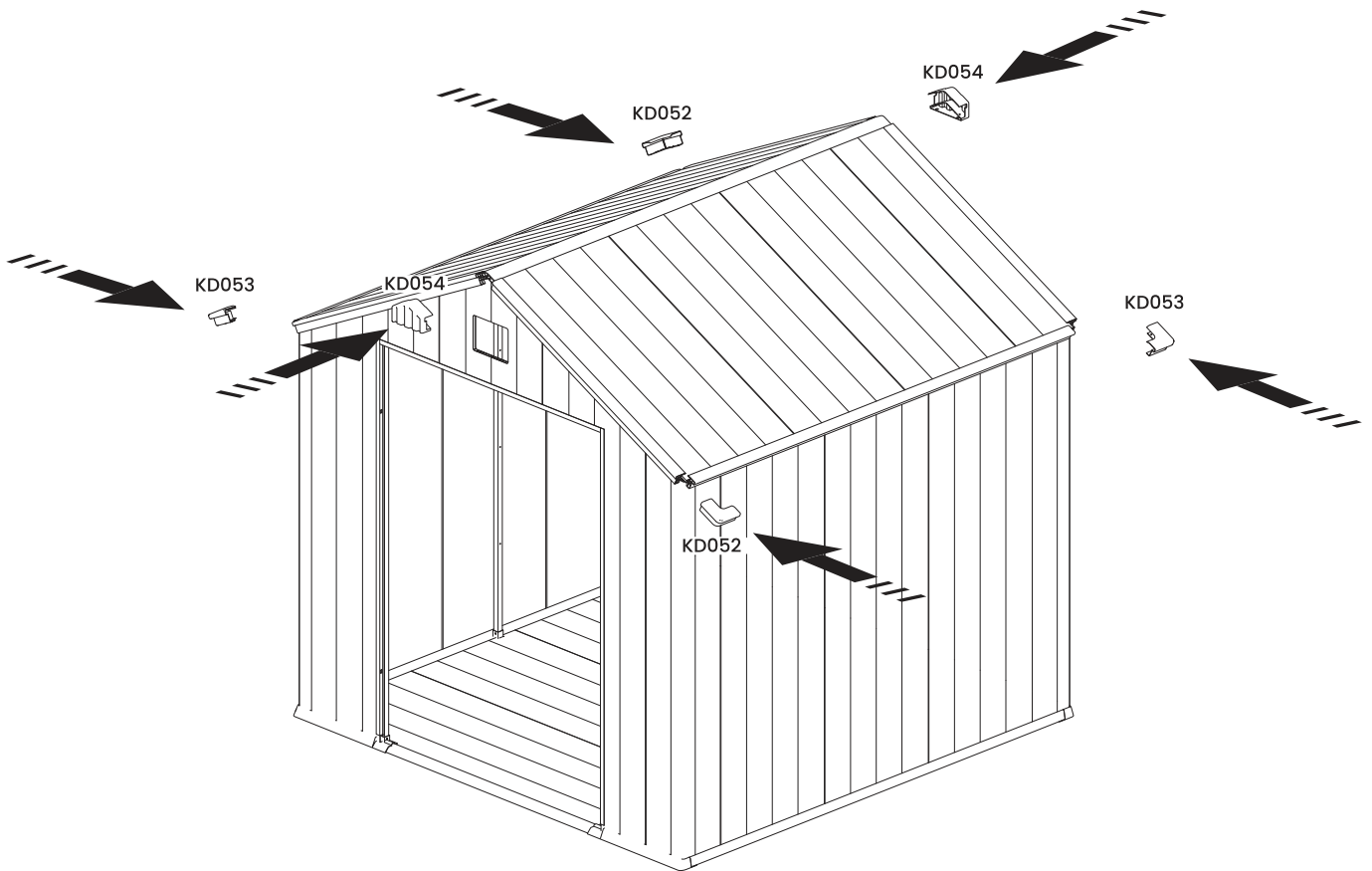



**Veillez à l'orientation de la fenêtre de ventilation.**  
Pay attention to the direction of the ventilation window.

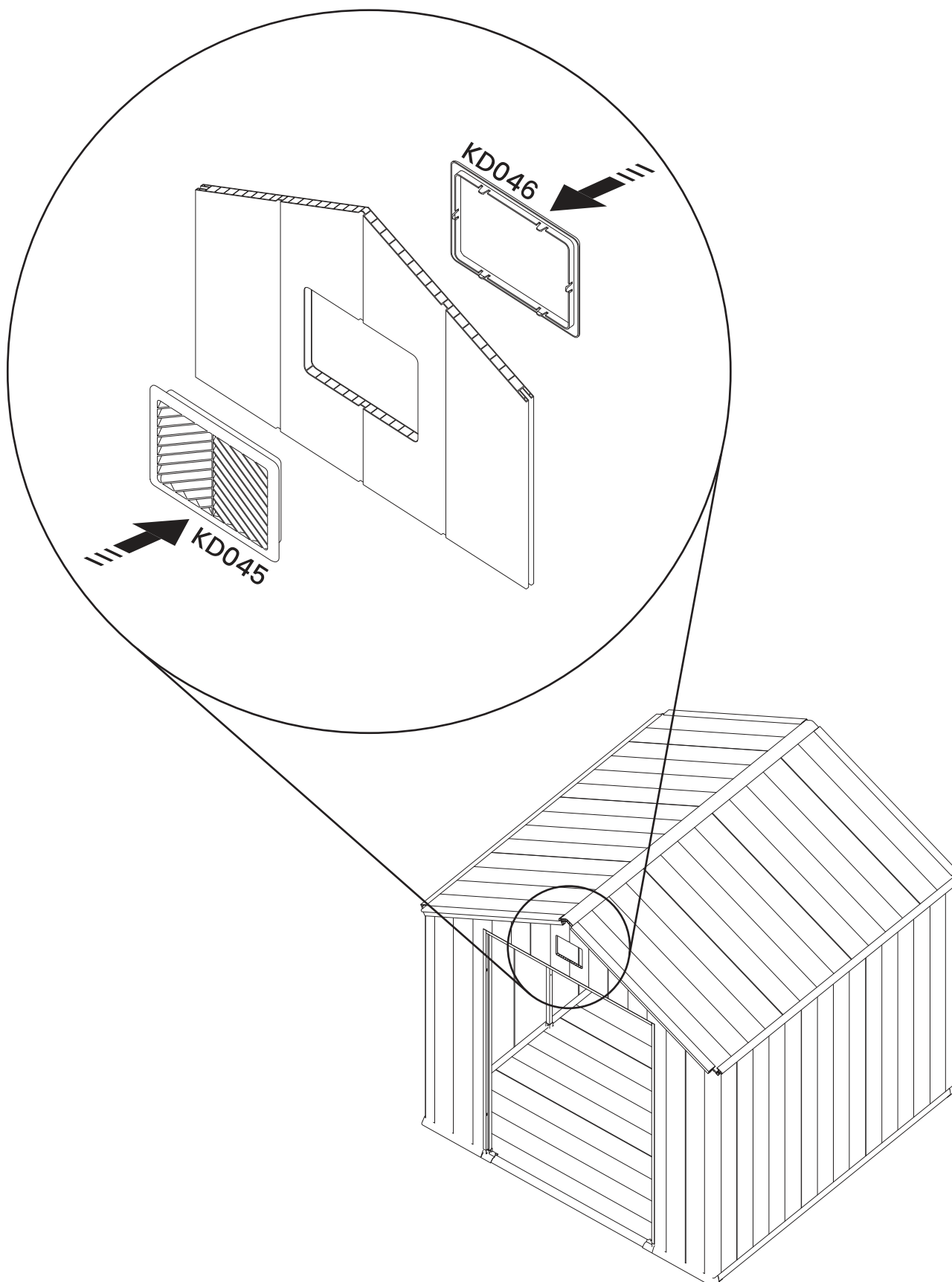

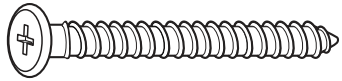

KD085

x22

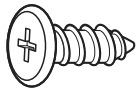
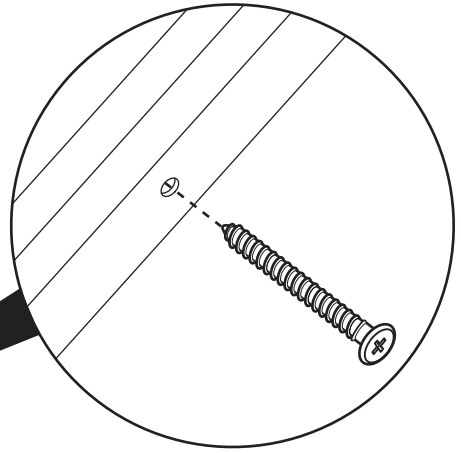
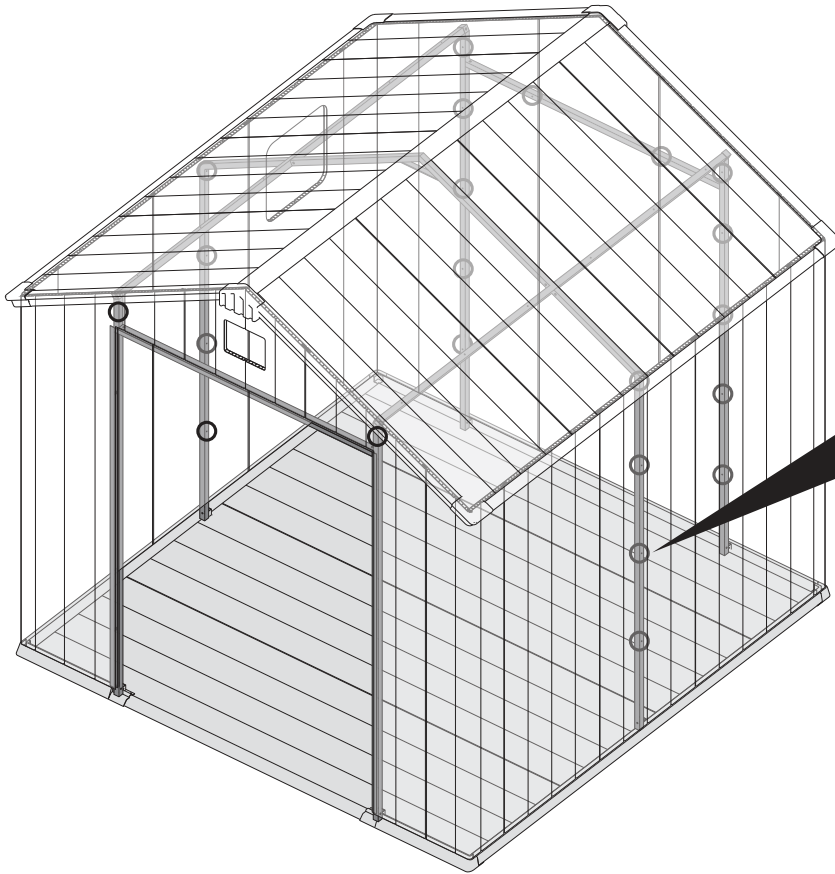

KD083

x8

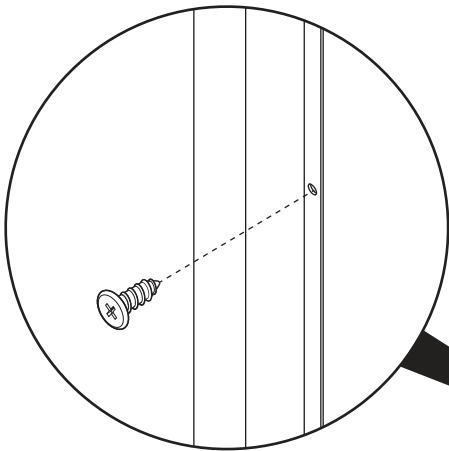
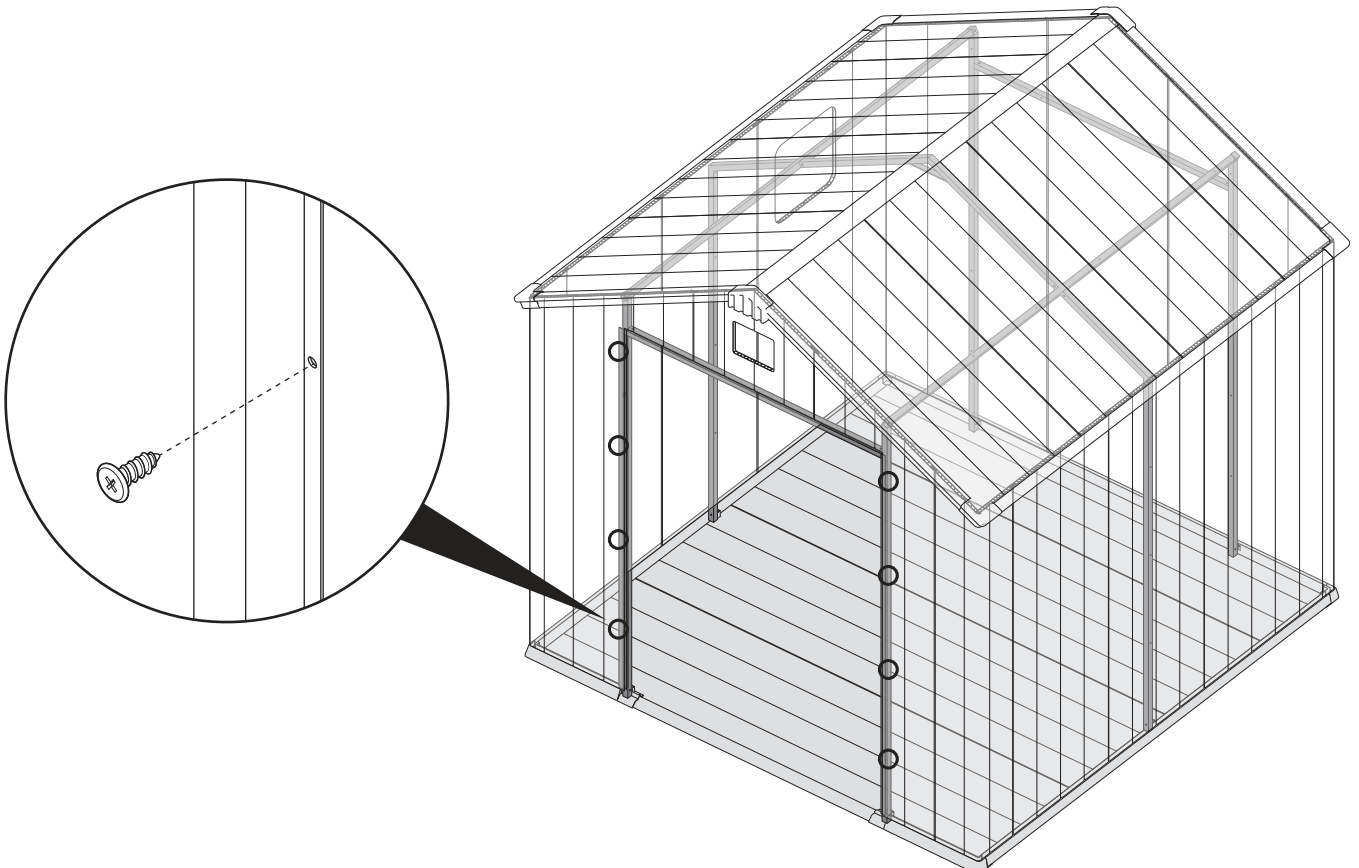



# Assemblage de porte

## Door Assembly

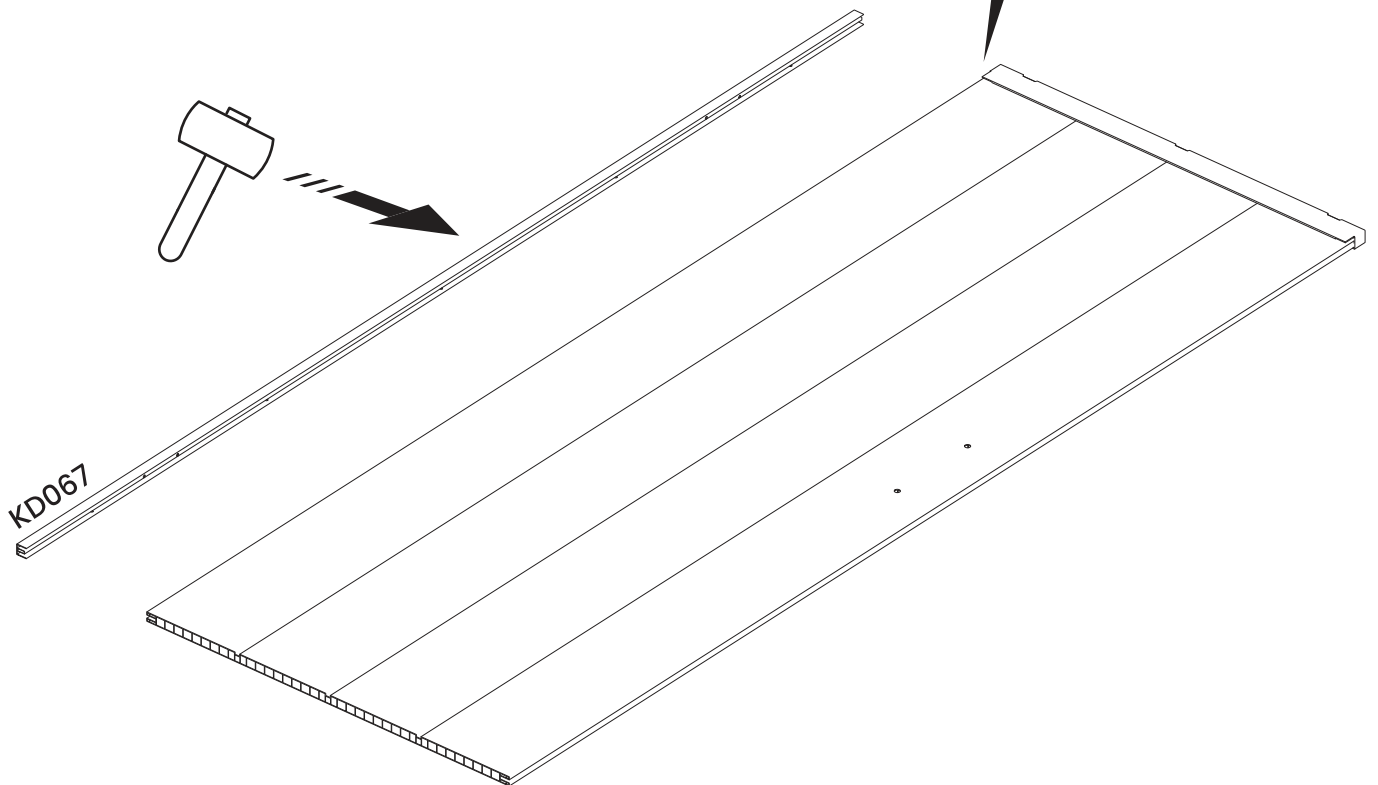
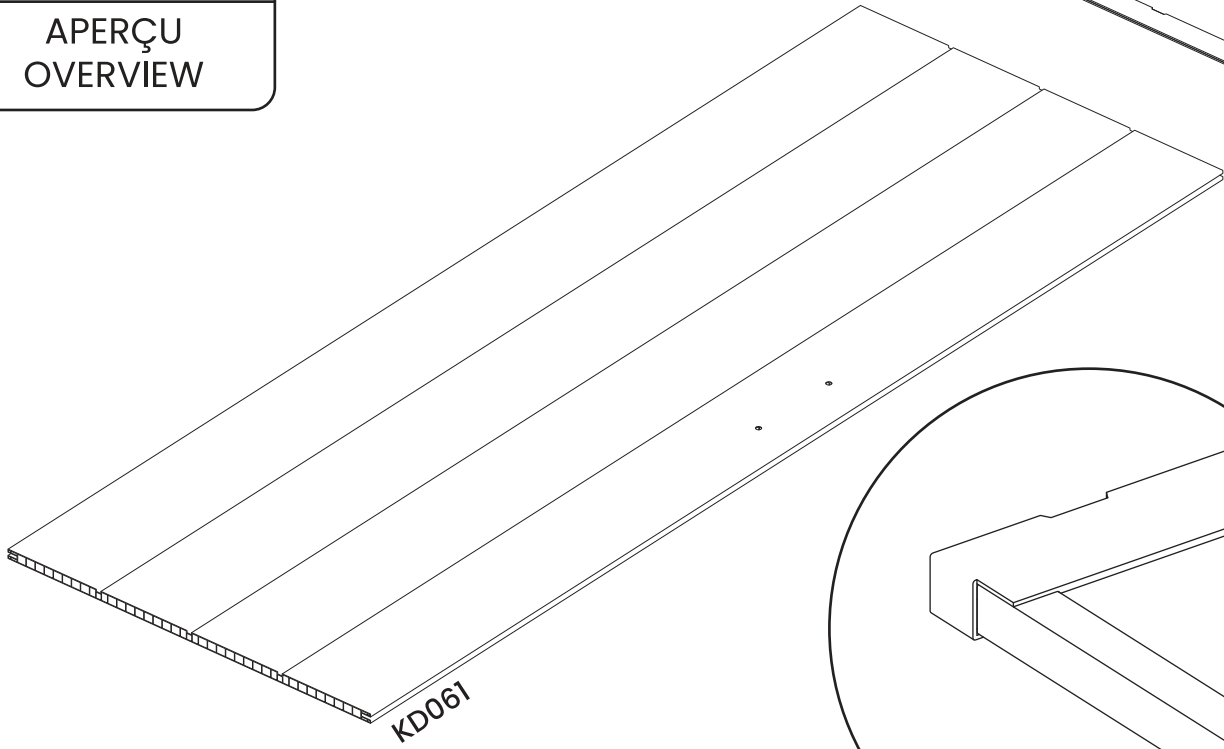
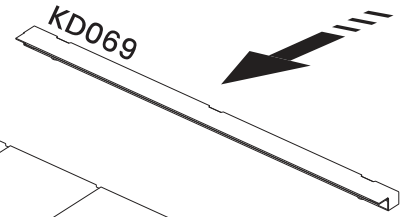
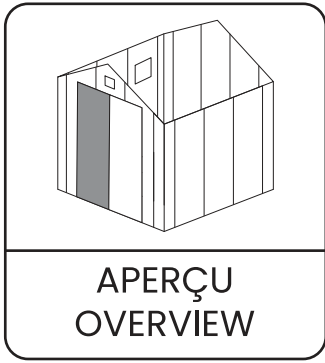



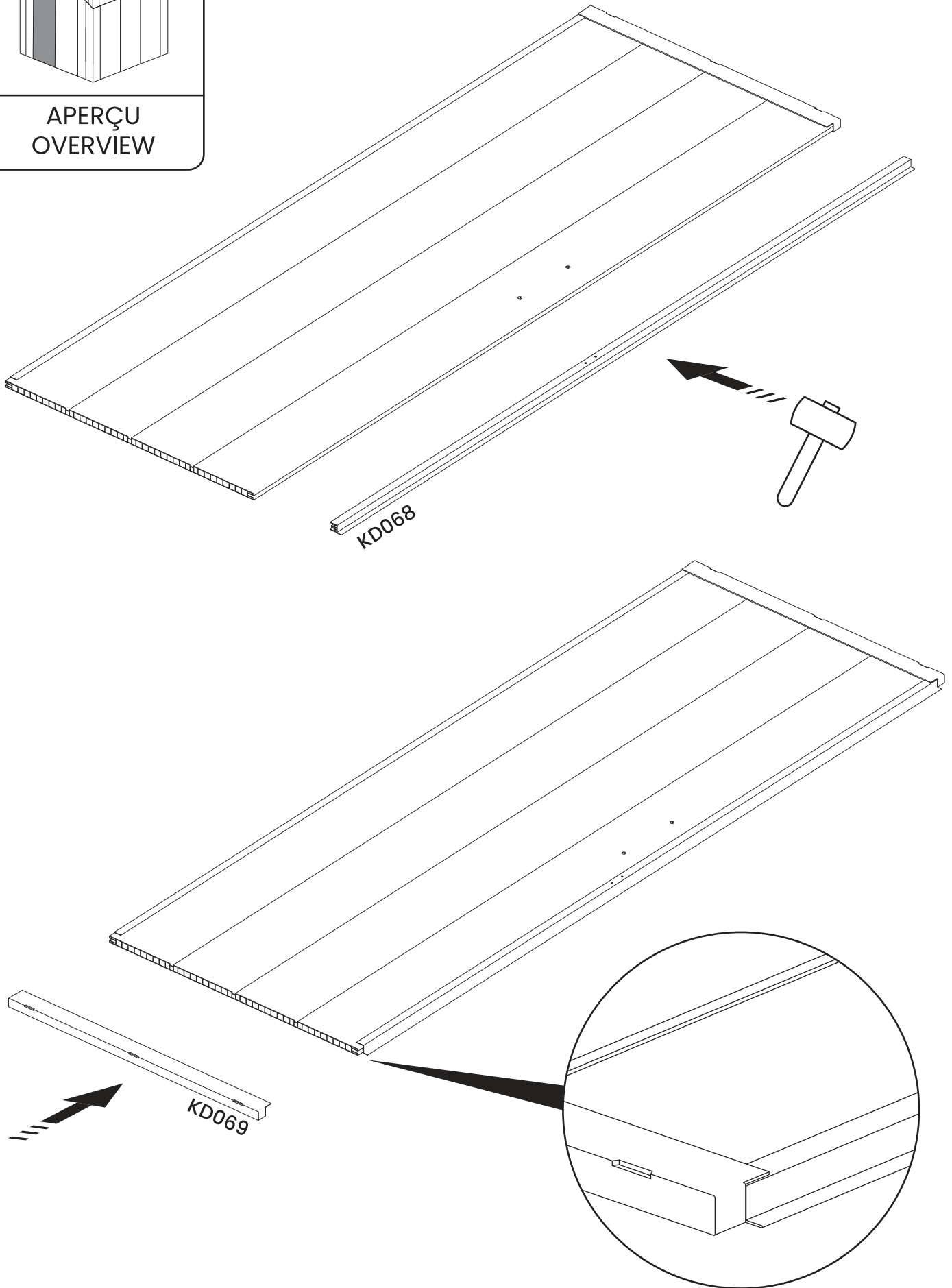
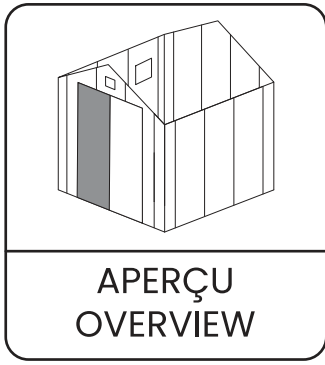

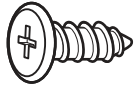

KD083

x14

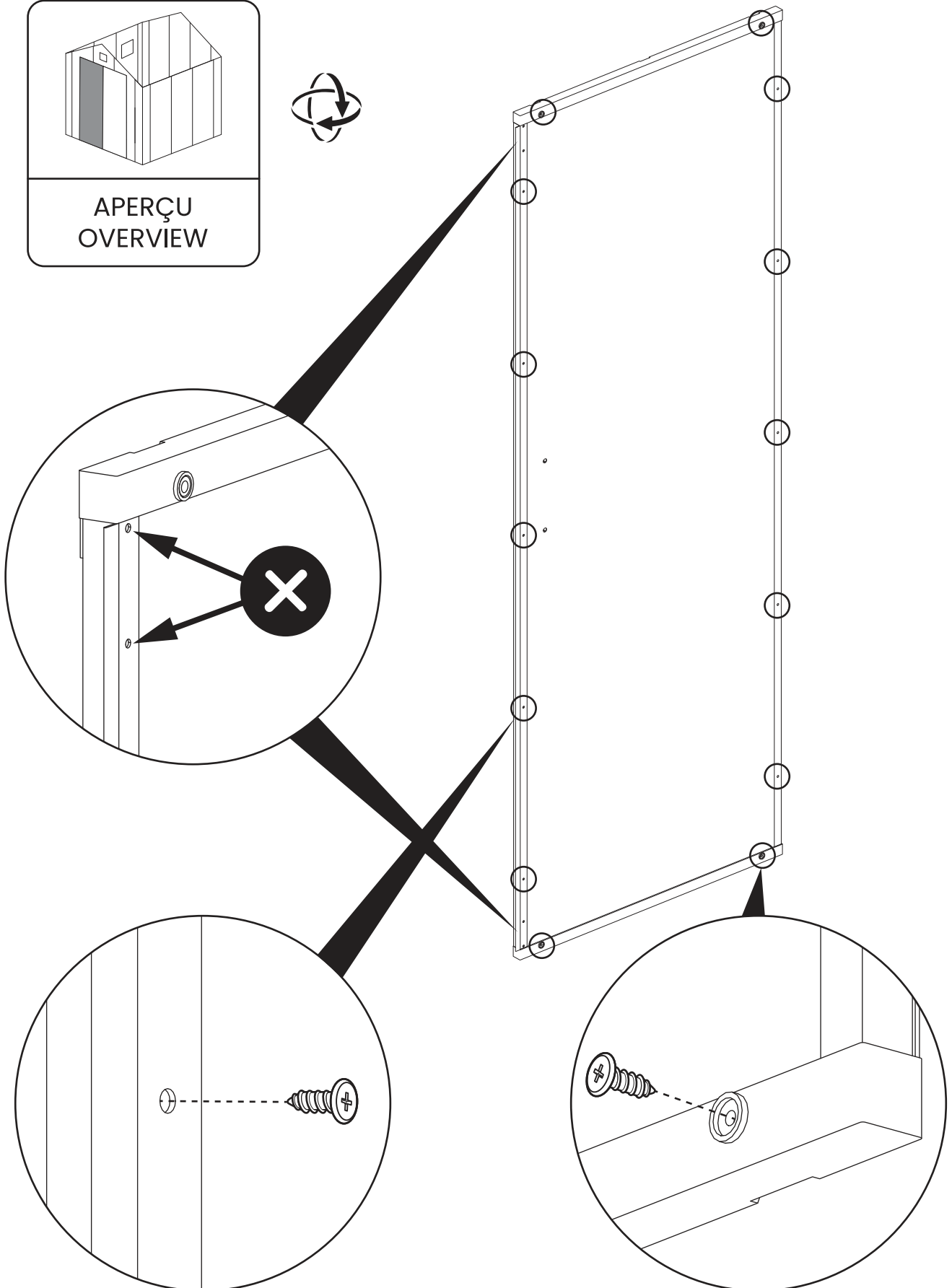
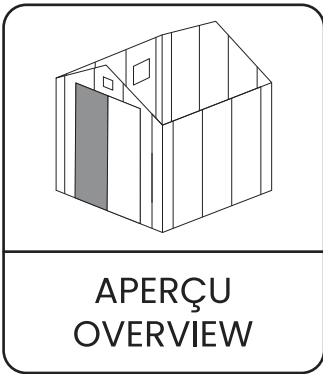

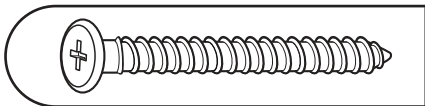

KD085

x4

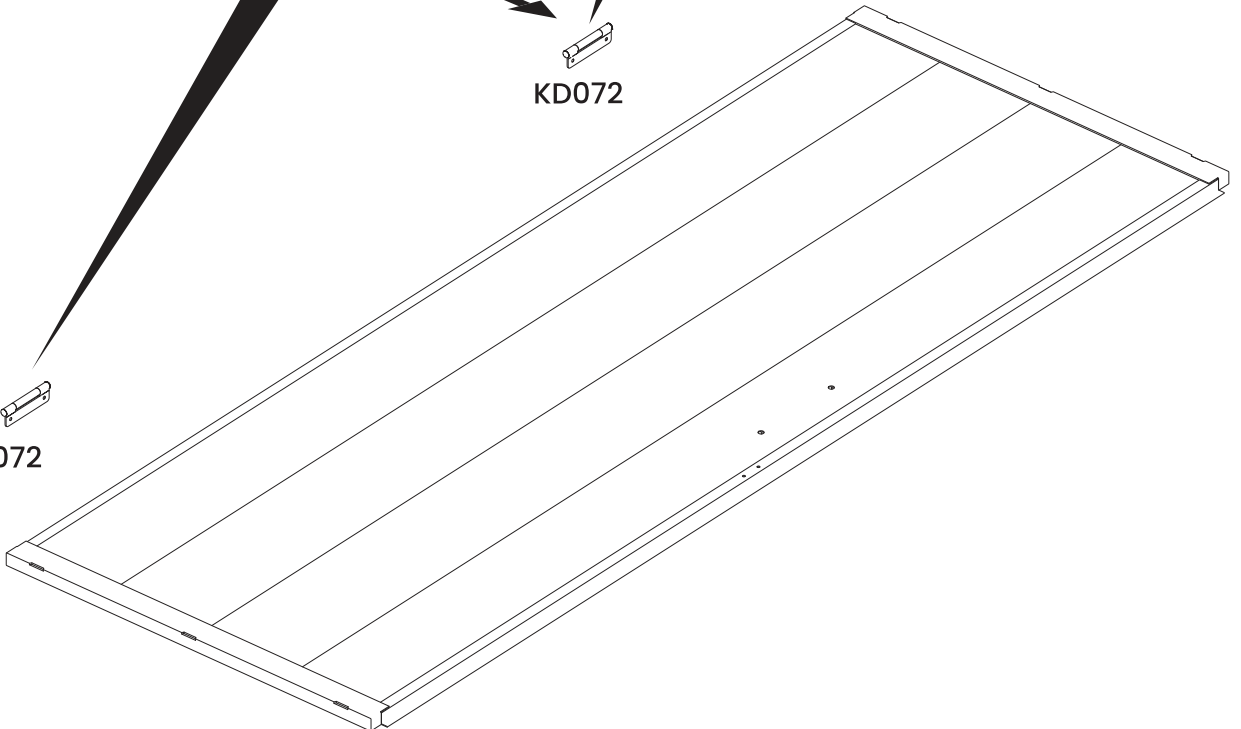
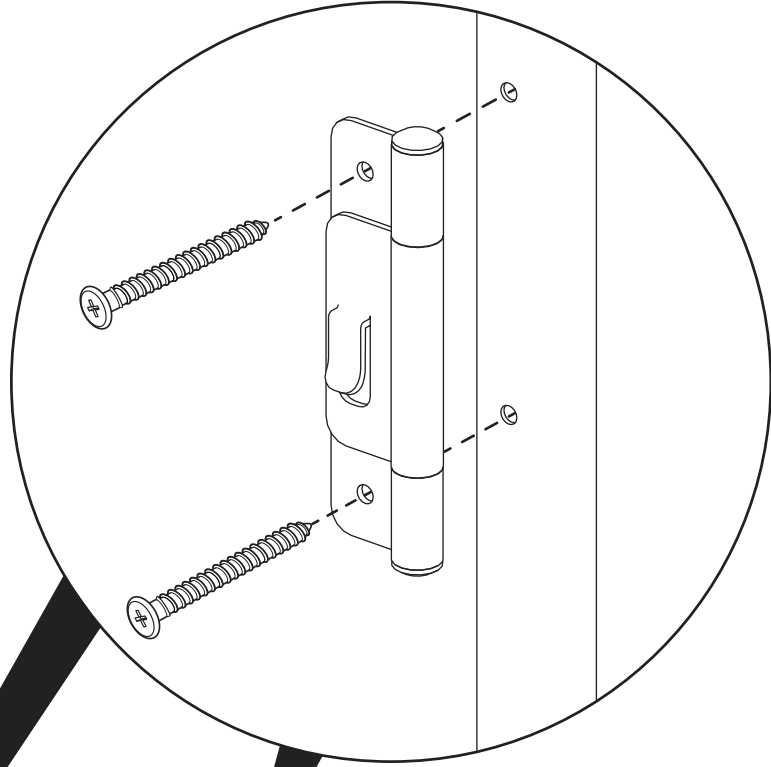
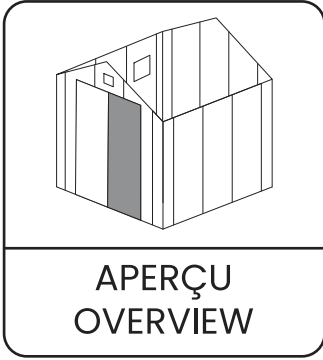

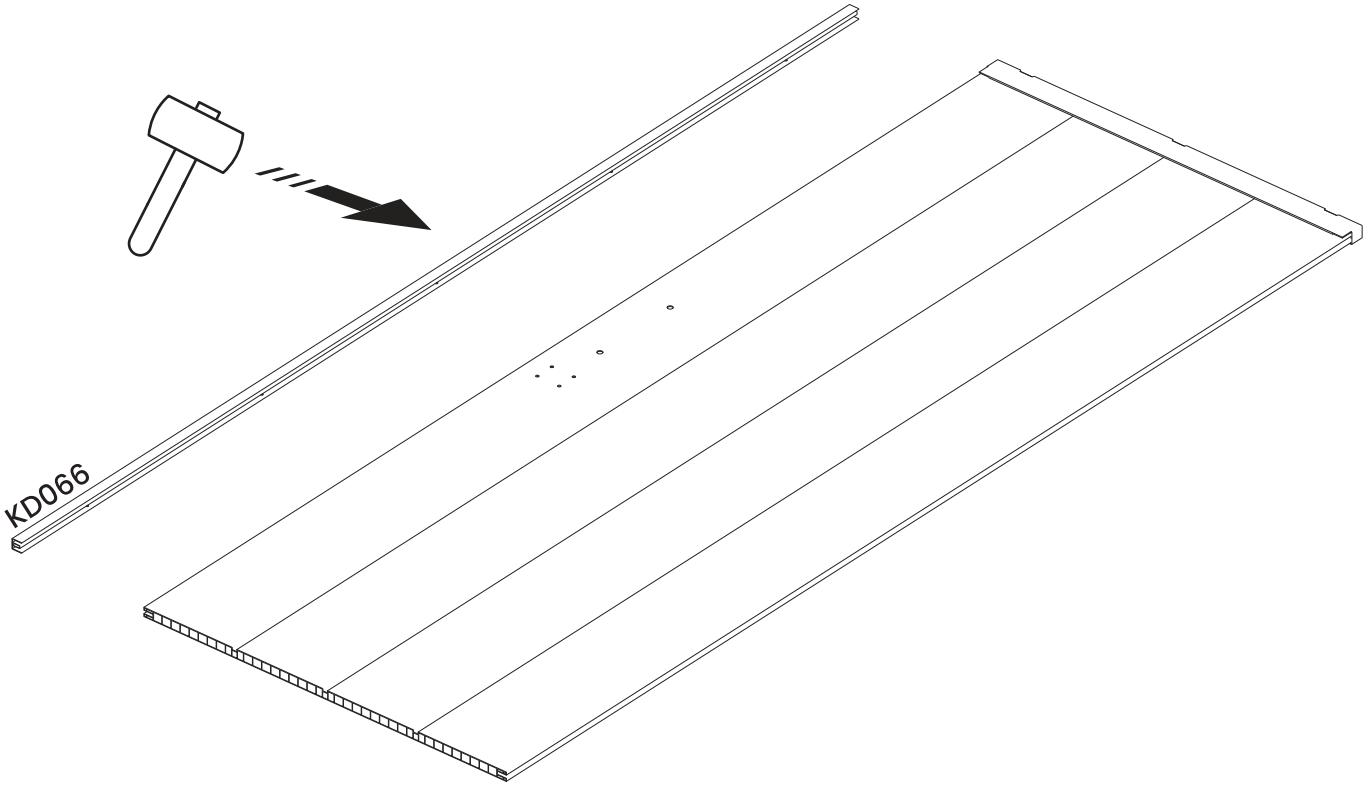
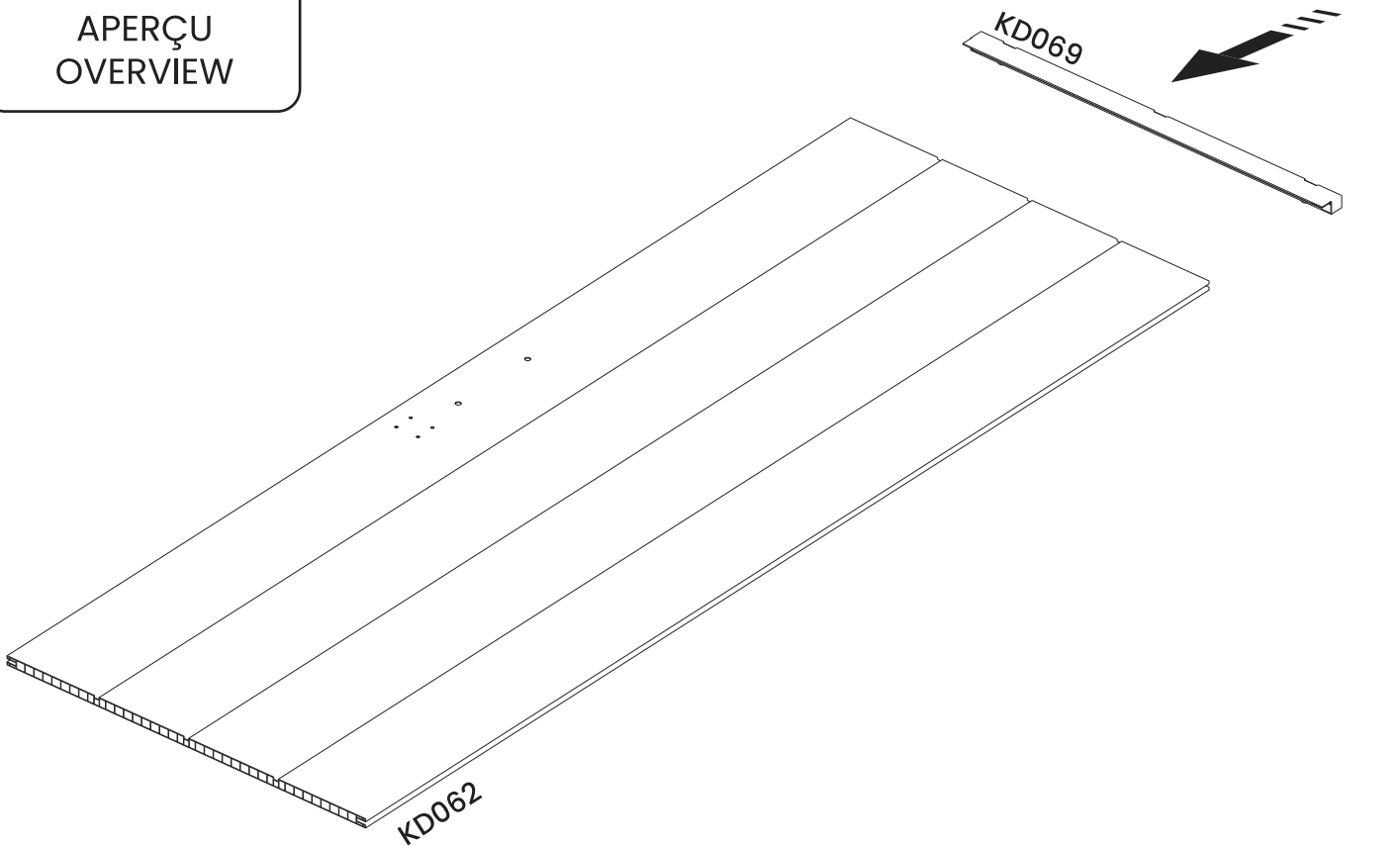
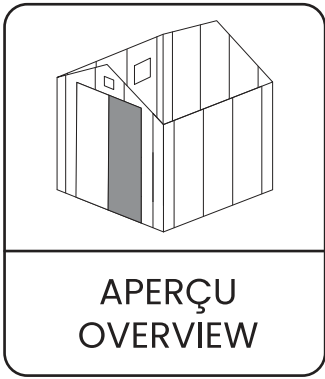

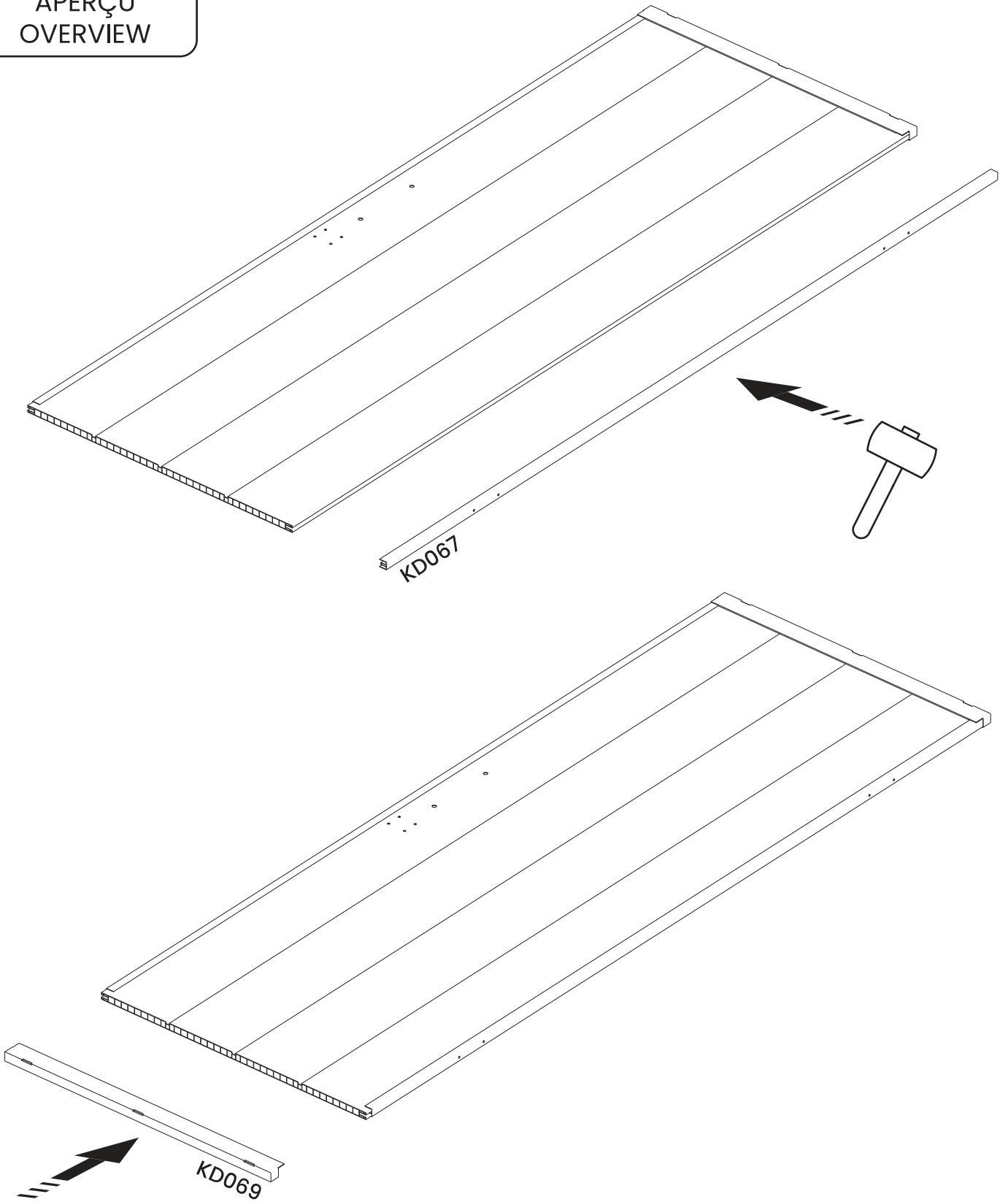
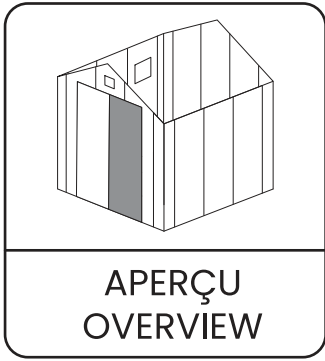

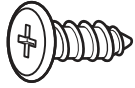

KD083

x14

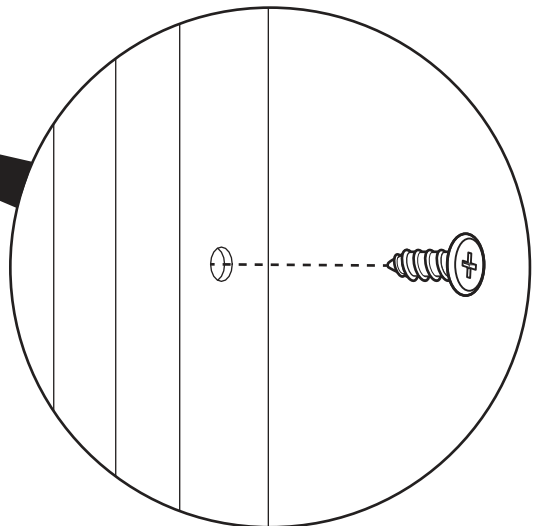
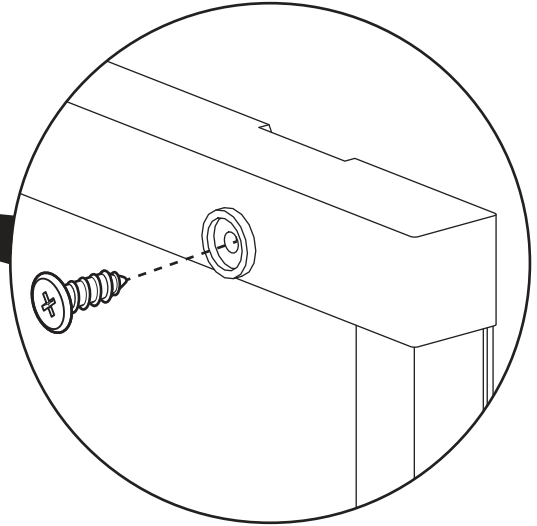
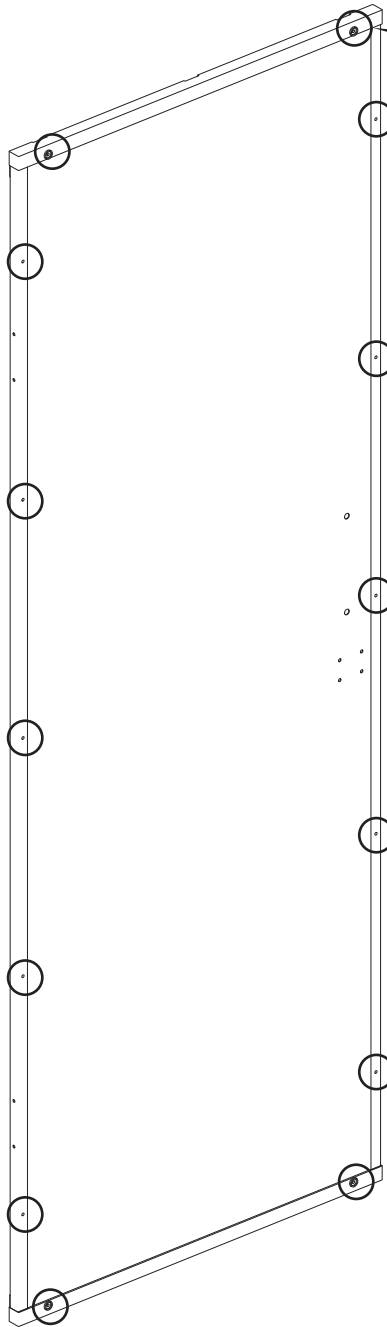
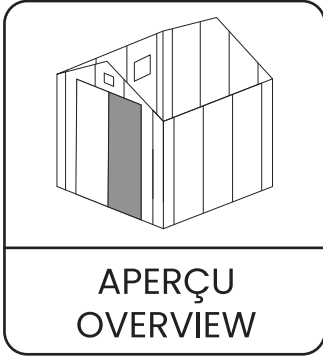

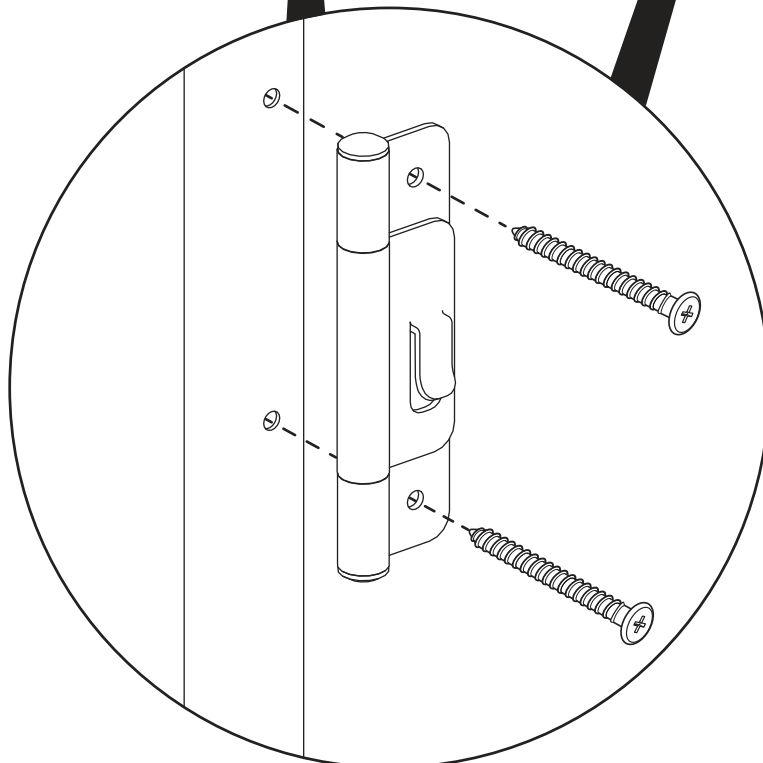
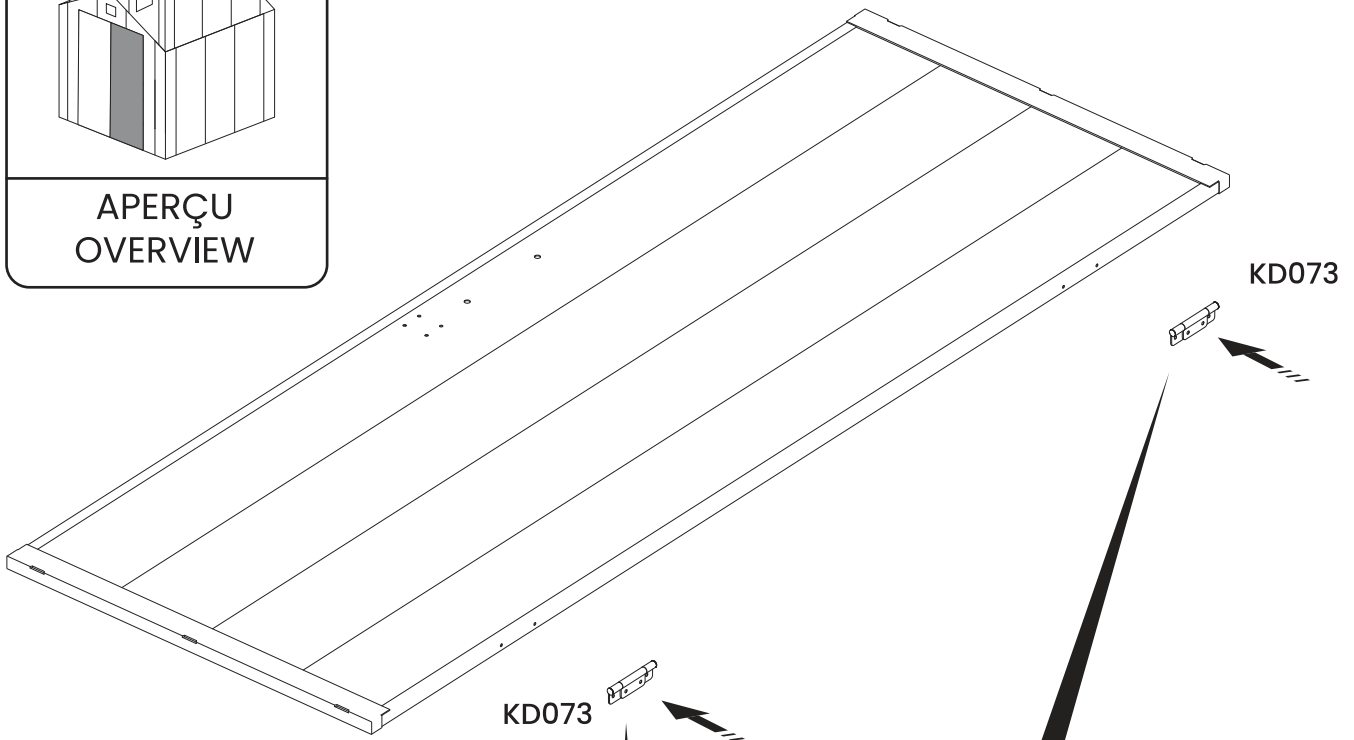
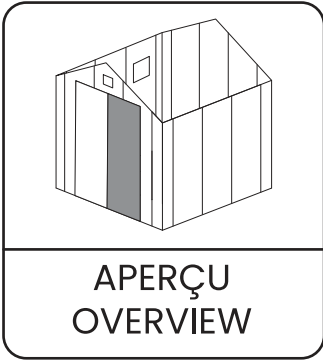

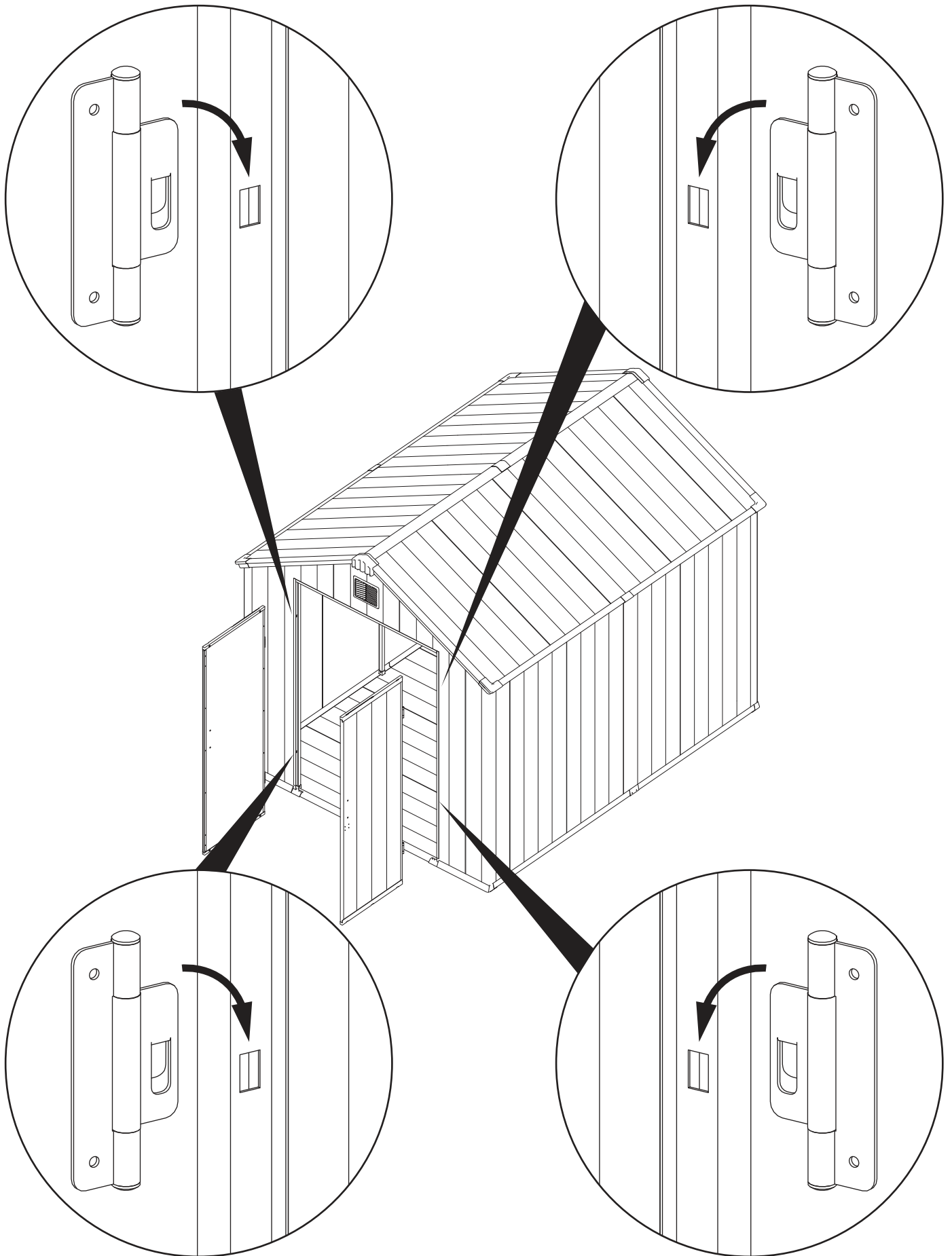



KD070 x2 KD071 x2 KD084 x4

KD079 x2 KD084 x4

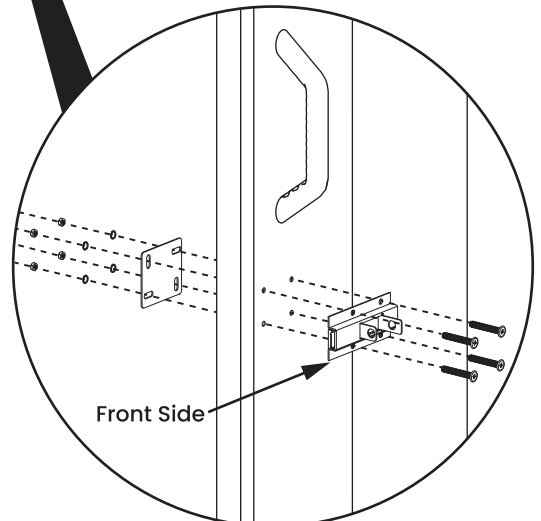
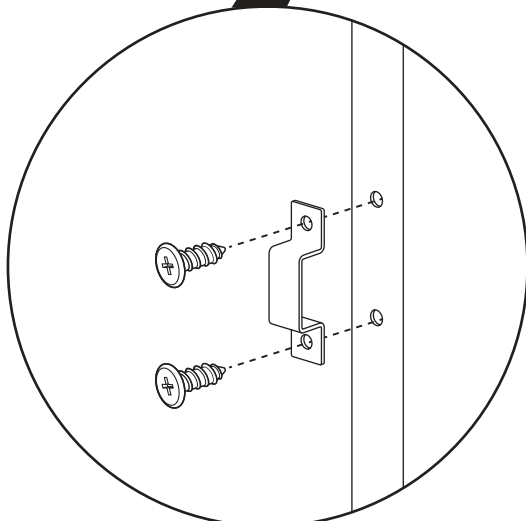
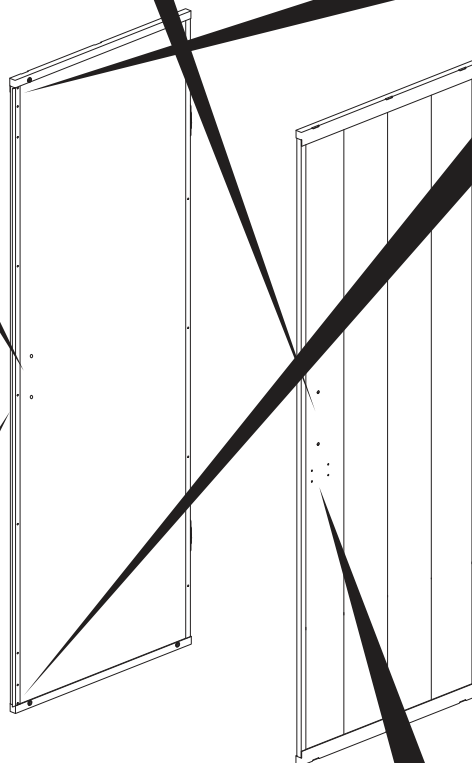
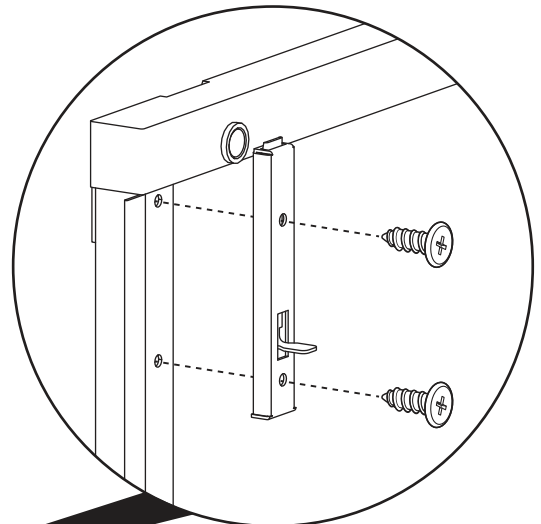
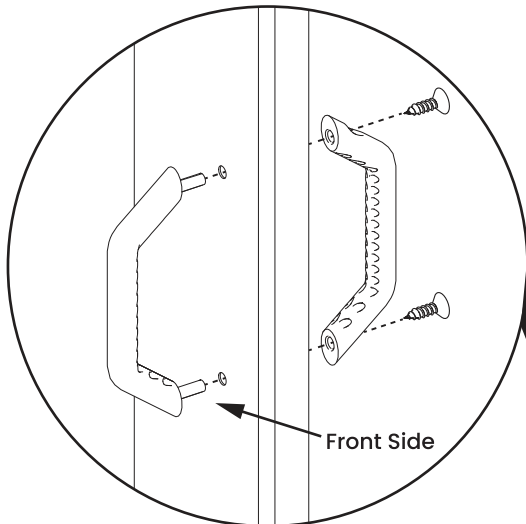

KD076 x1 KD083 x2

KD075 KD077 KD078 x4

# Schémas de sécurité / Security Schemes

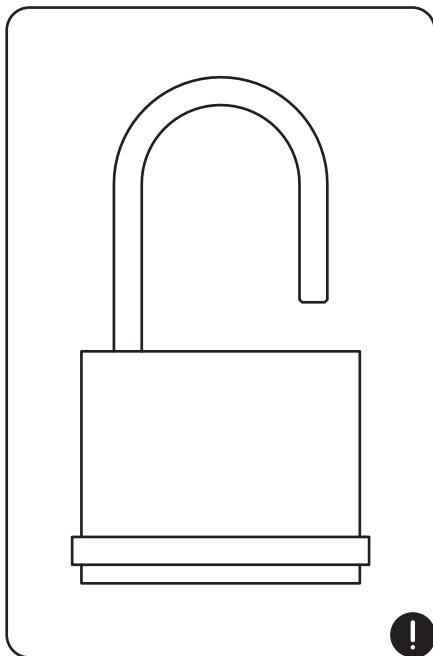

Non inclus / Not included

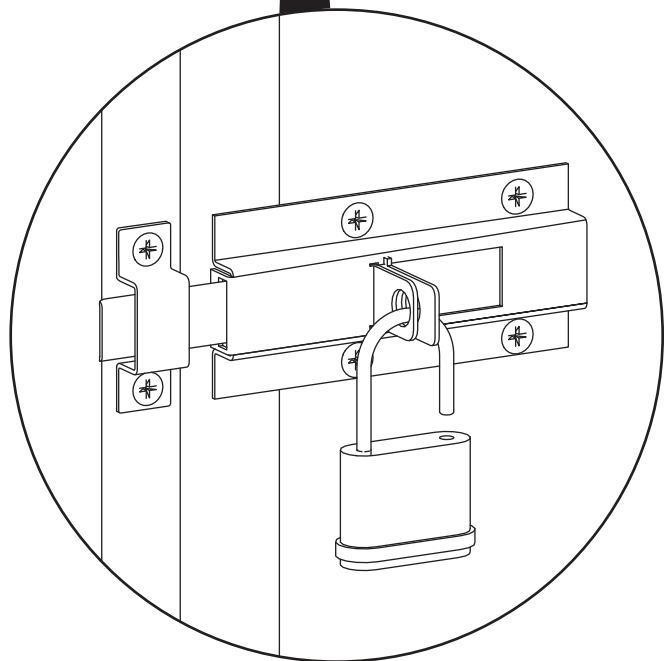



# Directives et garantie

## Guidelines & Warranty



## Conception sans entretien / Maintenance-Free Design

Le cabanon 2 versants est construit avec un matériau sans entretien qui élimine le besoin de peinture ou de vernis. Bien que les murs puissent être peints pour les personnaliser, aucun traitement supplémentaire n'est nécessaire pour maintenir la durabilité et l'apparence du cabanon.

The 2-sided shed is built with a maintenance-free material that eliminates the need for paint or varnish. While the walls can be painted for customization, no additional treatments are required to maintain the shed's durability and appearance.

## Murs à peindre uniques / Unique Paintable Walls

Le cabanon 2 versants est fabriqué à partir d'un composé unique sans entretien qui permet de peindre les panneaux muraux brossés, ce qui donne la possibilité de garder l'abri dans sa couleur d'origine ou de le personnaliser pour l'assortir à votre paysage, à votre terrasse, à votre patio ou à d'autres aménagements extérieurs.

The 2-sided Shed is crafted from a maintenance-free, unique compound that allows the brushed wall panels to be painted, giving you the option to keep the shed in its original color or to customize it to match your landscape, deck, patio, or other outdoor settings.

## Instructions pour la peinture / Painting Instructions

**\*\*Type de peinture\*\*** : Utiliser une peinture acrylique à base d'eau pour les applications extérieures. Il est recommandé d'utiliser des teintes claires et solides avec une finition satinée ou semi-brillante. Consulter un spécialiste des couleurs ou un professionnel de la peinture pour obtenir de l'aide dans le choix de la peinture.

**\*\*Application\*\*** : Appliquer la peinture au rouleau sur la surface du mur sec. Éviter de peindre les fissures des panneaux muraux qui ressemblent à des poutres.

**\*\*Zones à éviter\*\*** : Ne peignez pas les fenêtres, les portes, la poutre de la porte, le toit, le sol ou toute autre partie de l'abri autre que les murs désignés.

**\*\*Type of Paint\*\***: Use water-based acrylic paint for exterior applications. Solid, light shades with a satin or semi-gloss finish are recommended. Consult a color specialist or paint professional for assistance in selecting paint.

**\*\*Application\*\***: Apply paint with a roller on the dry wall surface. Avoid painting the beam-like crevices within the wall panels.

**\*\*Areas to Avoid\*\***: Do not paint the windows, doors, door beam, roof, floor, or any part of the shed other than the designated walls.

## Rappel de maintenance / Maintenance Reminder

La peinture peut nécessiter des retouches périodiques ou être repeinte au fil du temps pour conserver l'aspect de l'abri. Suivez toujours les consignes d'entretien et de sécurité du fabricant de la peinture avant de l'appliquer. En suivant ces instructions, vous pouvez personnaliser votre cabanon 2 versants pour qu'il s'intègre parfaitement à votre environnement extérieur.

Painting may require periodic touch-ups or repainting over time to maintain the shed's appearance. Always follow the paint manufacturer's care and safety guidelines before applying. By following these instructions, you can personalize your 2-sided shed to seamlessly integrate with your outdoor environment.

## Garantie à vie limitée de le cabanon 2 versants / The 2-sided Shed Limited Lifetime Warranty

Votre cabanon 2 versants (« le produit ») est fabriqué à partir de matériaux recyclables de haute qualité, sous un contrôle de qualité strict. Cette garantie protège le produit contre toute défaillance due à des défauts de fabrication ou de matériaux, pour une durée illimitée à compter de la date d'achat au détail. Par « défauts », on entend ici les imperfections qui empêchent l'utilisation du produit. En cas de défaut, le consommateur doit permettre à Cabanon Design, ou à ses représentants, d'inspecter ou de tester le produit dans un établissement Cabanon Design ou à un autre endroit à la discrétion de Cabanon Design.

Limitations de la garantie : Cette garantie ne couvre pas les dommages causés par :

L'usure normale (par exemple, les éraflures, les rayures ou les fractures résultant d'une utilisation régulière).

Décoloration, décoloration ou rouille

d'une utilisation déraisonnable, d'un abus, d'une négligence ou de modifications non autorisées.

Peinture, déplacement, transport ou relocalisation du produit

L'assemblage ou la manipulation non conforme aux directives énoncées dans le manuel de l'utilisateur, ou toute utilisation commerciale ou publique du produit, annulera la présente garantie.

Cabanon Design n'est pas responsable des dommages causés au consommateur, à des tiers ou à des objets personnels stockés dans ou à proximité du cabanon.

Processus de réclamation : Pour déposer une réclamation au titre de la garantie, vous devez fournir une preuve d'achat et une preuve de la défectuosité dans un délai raisonnable. Cabanon Design, à sa seule discrétion, peut choisir de remplacer la ou les pièces défectueuses ou d'offrir un remboursement au prorata sur la base d'une dépréciation linéaire de 10% par an, la valeur restante étant fixée à 10% pour la durée de la garantie.

Your 2-sided shed ("the Product") is crafted from high-quality, recyclable materials under strict quality control. This warranty protects against product failure due to defects in manufacturing or materials for an unlimited duration from the original retail purchase date. Here, "defects" refer to imperfections that hinder the Product's use. In the event of a defect, the consumer must allow Kenda, or its representatives, to inspect or test the product at a Cabanon Design facility or another location at Cabanon Design discretion.

Warranty Limitations: This warranty does not cover damage from:

Normal wear and tear (e.g., scuffing, scratches, or fractures from regular use)

Discoloration, fading, or rusting

Unreasonable use, abuse, negligence, or unauthorized alterations

Painting, moving, transporting, or relocating the Product

Assembly or handling that fails to comply with the guidelines outlined in the user manual, or any commercial/public use of the Product, will void this warranty.

Cabanon Design is not liable for damage to the consumer, third parties or personal items stored in or near the garden shed, or in the vicinity of the garden shed.

Claim Process: To file a warranty claim, you must provide proof of purchase and evidence of the defect within a reasonable timeframe.

Cabanon Design, at its sole discretion, may choose to either replace the defective part(s) or offer a prorated refund based on a straight-line depreciation of 10% annually, with the remaining value fixed at 10% for the warranty's duration.

# Conseils d'entretien et de sécurité pour le cabanon 2 versants / 2-sided shed Care and Safety Guidelines

Le cabanon 2 versants est conçu uniquement à des fins de stockage et n'est pas destiné à l'habitation. Veuillez respecter les consignes d'entretien et de sécurité suivantes afin de garantir des performances et une sécurité optimales :

The 2-sided shed is designed strictly for storage purposes and is not intended for habitation. Please adhere to the following care and safety guidelines to ensure optimal performance and safety:

## **\*\*Assemblage et stabilité\*\* / \*\*Assembly and Stability\*\***

- Ancrez le cabanon à un objet fixe ou fixez-le au sol en perçant le sol aux endroits prévus à cet effet et en insérant les vis appropriées.
- Évitez de monter l'abri les jours de vent ou de froid.
- Inspectez régulièrement l'abri pour en vérifier la stabilité et vous assurer que le sol reste plat.
- Anchor the shed to a fixed object or secure it to the ground by drilling at pre-marked locations in the floor and inserting appropriate screws.
- Avoid assembling the shed on windy or cold days.
- Regularly inspect the shed to confirm stability and ensure the ground remains level.

## **\*\*Manipulation et assemblage\*\* / \*\*Handling and Assembly\*\***

- Soyez prudent avec les pièces à arêtes en acier pour éviter les blessures.
- N'utilisez que les outils indiqués dans le manuel lors de l'assemblage ou de la manipulation.
- Éloignez les tondeuses à gazon et les faux mécaniques du cabanon afin d'éviter tout dommage accidentel.
- Portez des lunettes de sécurité et respectez les instructions du fabricant lorsque vous utilisez des outils électriques.
- Exercise caution with steel-edged parts to prevent injury.
- Only use the tools listed in the manual during assembly or handling.
- Keep lawnmowers and mechanical scythes away from the shed to avoid accidental damage.
- Wear safety goggles and adhere to manufacturer instructions when operating power tools.

## **\*\*Nettoyage et maintenance\*\* / \*\*Cleaning and Maintenance\*\***

- Nettoyez le cabanon avec un tuyau d'arrosage ou une solution détergente douce. Évitez d'utiliser des brosses dures ou des nettoyeurs abrasifs, y compris des dégraissants et des produits à base d'huile ou d'acétone, car ils risquent de tacher ou d'endommager le matériau.
- Clean the shed with a garden hose or a mild detergent solution. Avoid using stiff brushes or abrasive cleaners, including degreasers and oil- or acetone-based products, as they may stain or damage the material.

## **\*\*Précautions de stockage\*\* / \*\*Storage Precautions\*\***

- Ne stockez pas d'objets chauds, tels que des grills ou des chalumeaux récemment utilisés, et évitez de stocker des produits chimiques volatils.
- Ne placez pas d'objets lourds contre les murs, car cela pourrait provoquer des déformations.
- Débarrassez le toit de la neige et des feuilles qui s'y sont accumulées afin d'éviter tout dommage et de garantir un accès sûr.
- Do not store hot items, such as recently used grills or blowtorches, and avoid storing volatile chemicals.
- Refrain from placing heavy objects against the walls, as this could cause distortion.
- Keep the roof clear of accumulated snow and leaves to prevent damage and maintain safe access.

## **\*\*Considérations météorologiques\*\* / \*\*Weather Considerations\*\***

- Lorsque vous placez le cabanon tenez compte de la direction du vent pour minimiser l'exposition, en particulier du côté de la porte. Gardez les portes fermées et verrouillées lorsque l'abri n'est pas utilisé afin d'éviter les dommages causés par le vent.
- Évitez de vous tenir sur le toit.
- When positioning the shed, consider wind direction to minimize exposure, particularly on the door side. Keep doors closed and locked when the shed is not in use to prevent wind damage.
- Avoid standing on the roof.

## **\*\*Autorisations\*\* / \*\*Permits\*\***

- Consultez les autorités locales pour savoir si un permis est nécessaire pour l'installation du cabanon 2 versants dans votre région.
- Consult your local authorities to find out whether a permit is required for the installation of the 2-sided shed in your area.

**En suivant ces conseils, vous vous assurerez que votre cabanon 2 versants reste une solution de stockage sûre et fonctionnelle.**

By following these guidelines, you'll help ensure that your 2-sided Shed remains a safe and functional storage solution.



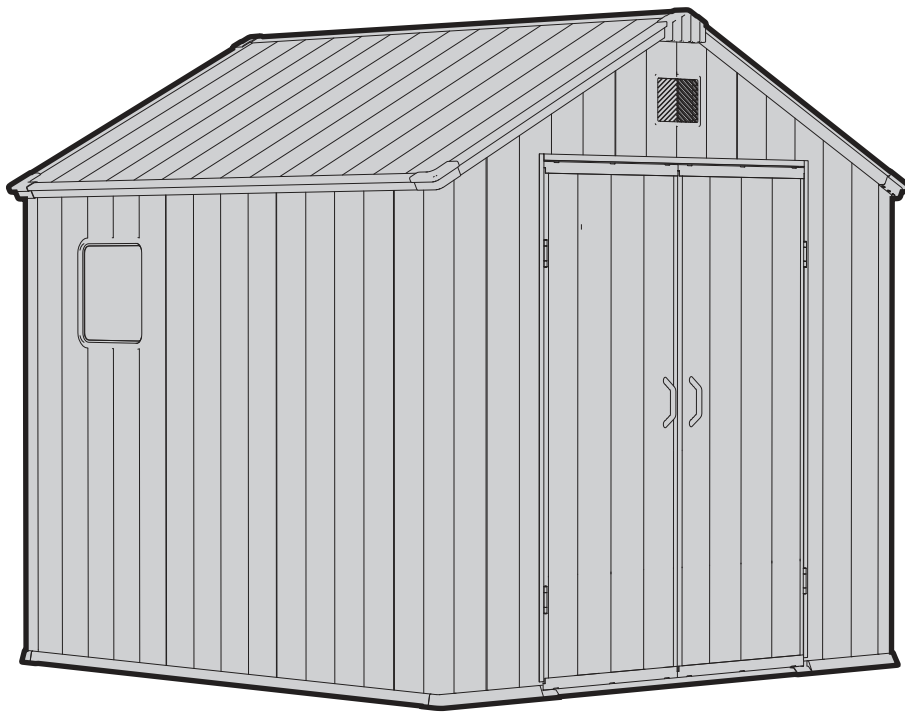

Version 2.0  
Revised 18.Jan.2025